

2025 collection



Minotti



Minotti

Il nostro spirito imprenditoriale, permeato da sperimentazione, audacia, piacere, sobrietà e solidità continua ad inseguire il proprio sogno di perfezione e bellezza con grande determinazione, accelerando la sua corsa come noi amiamo fare.

Lanciamo un'unica poderosa "2025 Collection" che raccoglie cinque famiglie di prodotto, cinque proposte contestualizzate in cinque scenari abitativi, cinque progetti ideati dai cinque designer in stretto dialogo con la nostra famiglia.

Insieme uniti e guidati da passione, ambizione, ossessione per i dettagli, senso estetico, impeccabile artigianalità, valori fondamentali impressi nel DNA Minotti.

Lavoriamo con rispetto per il passato, attenzione al presente e una visione chiara nel tracciare un percorso innovativo e sorprendente verso il futuro.

This is Minotti.

Our entrepreneurial spirit, defined by experimentation, audacity, pleasure, sobriety and solidity, continues to pursue its dream of perfection and beauty with absolute determination, accelerating its pace as we love to do.

We are launching a one-of-a-kind, strong "2025 Collection" which brings together five product families, five proposals contextualised in five living scenarios, five projects conceived by five designers working jointly with our family.

Together, united and guided by passion, ambition, obsession with details, aesthetic sense and impeccable craftsmanship, core values embedded in the Minotti DNA.

We work with respect for the past, attention for the present, and a clear vision in tracing an innovative and surprising path toward the future.

This is Minotti.

Indoor index



COUPÉ
GIAMPIERO TAGLIAFERRI
08



BÉZIER
MARCIO KOGAN / STUDIO MK27
56



RILEY
HANNES PEER
108



VIVIENNE
GAMFRATESI
158



SAKI
NENDO
212



LIBRA
GIAMPIERO TAGLIAFERRI
18 - 36 - 81



LAUREL
GIAMPIERO TAGLIAFERRI
90 - 104 - 142 - 174



TAPE DINING (UPDATE)
NENDO
240



TRIO DINING (UPDATE)
MARCIO KOGAN / STUDIO MK27
102



SENDAI DINING (UPDATE)
INODA+SVEJE
247



YOKO DINING (UPDATE)
INODA+SVEJE
106



LIBRA COFFEE TABLE
GIAMPIERO TAGLIAFERRI
17 - 122



ANDRÉE
HANNES PEER
24 - 34 - 177



NASTRO
GIAMPIERO TAGLIAFERRI
82 - 202 - 227



BÉZIER COFFEE TABLE
MARCIO KOGAN / STUDIO MK27
78 - 199 - 232



YVES COFFEE TABLE AND CONSOLE TABLE
HANNES PEER
128 - 130 - 166 - 182



STAGE
HANNES PEER
156



CAMEO
HANNES PEER
135



HELENE (UPDATE)
HANNES PEER
160



TAIKO (UPDATE)
NENDO
208 - 214



YVES SIDEBOARD
HANNES PEER
186



LIBRA SIDEBOARD
GIAMPIERO TAGLIAFERRI
116



DIAGRAMMA SIDEBOARD
GIAMPIERO TAGLIAFERRI
40 - 218



SUPERBLOCKS (UPDATE)
MARCIO KOGAN / STUDIO MK27
350



FILL (UPDATE)
HANNES PEER
51 - 55



ZOE (UPDATE)
HANNES PEER
70



LIBRA TABLE
GIAMPIERO TAGLIAFERRI
18



LINHA LIVRE
MARCIO KOGAN / STUDIO MK27
98



SAKI TABLE
NENDO
238



ZEALAND
MINOTTI STUDIO
44 - 125



FAIRWAY
MINOTTI STUDIO
98 - 148



LIBRA BED
GIAMPIERO TAGLIAFERRI
50

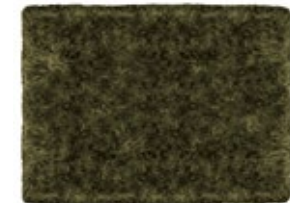

ALPS (UPDATE)
MINOTTI STUDIO
126

Outdoor index



BÉZIER CORD OUTDOOR
MARCIO KOGAN / STUDIO MK27
250



SAKI OUTDOOR - SAKI CORD OUTDOOR
NENDO
284



EMMI CORD OUTDOOR
HANNES PEER
306



BÉZIER OUTDOOR
MARCIO KOGAN / STUDIO MK27
270 - 276



ANDRÉE OUTDOOR
HANNES PEER
288 - 302



TAIKO OUTDOOR (UPDATE)
NENDO
257 - 278



ANDRÉE DINING OUTDOOR
HANNES PEER
282

"A seating experience that is both nostalgic and forward-thinking: we have reinterpreted classic forms through a contemporary lens, finding a balance between vintage charm and modern functionality."

BY GIAMPIERO TAGLIAFERRI

Coupé











LIBRA DINING TABLE | LIBRA DINING LITTLE ARMCHAIRS





COUPÉ MODULAR SEATING SYSTEM | LIBRA ARMCHAIR | LIBRA COFFEE TABLE | NASTRO SIDE TABLE | ANDRÉE COFFEE TABLE | ALPS RUG









Una silhouette distintiva, caratterizzata da volumi tondeggianti sovrapposti di chiara matrice anni '60 e '70, dà vita al sistema di sedute Coupé di Giampiero Tagliaferri.

Il designer considera il progetto "una vera e propria seating experience nostalgica, ma al contempo lungimirante: abbiamo reinterpretato le forme classiche attraverso una lente contemporanea, trovando un equilibrio tra fascino vintage e funzionalità moderna." Il richiamo all'estetica del modernismo del XX secolo si sintetizza nelle forme morbide, oltre che nei preziosi dettagli couture come le cuciture longitudinali, volutamente tono su tono, presenti nella versione in pelle: un elegante tratto grafico, espressione dell'alta manifattura artigianale firmata Minotti, che scandisce l'intero volume a partire dal poggiatesta, passando in coincidenza con i bottoni sullo schienale, fino a percorrere tutta la seduta. Le forme avvolgenti e la sinuosità ergonomica di Coupé, garantita dall'inclinazione del sedile appositamente progettata per conferire il massimo comfort, si incrociano con la forte orizzontalità degli elementi imbottiti di poggiatesta e poggiaeri, creando un'accattivante dinamicità visiva che sfocia nella vista del bracciolo, a evidenziare la sezione del divano.

"Alla base di questo design c'è un profondo rispetto per il passato, un omaggio a un'epoca in cui i divani abbracciavano il corpo con sedute inclinate, offrendo raffinatezza e un comfort senza precedenti", conferma Tagliaferri. Contraddistinto da un ampio abaco, il programma permette di disegnare layout flessibili e di prevedere sia l'aggregazione di sedute che l'utilizzo di elementi singoli in modo indipendente; tra loro spicca un couch, dalle proporzioni decisamente generose, caratterizzato da una doppia inclinazione. Dal tratto fortemente riconoscibile, questo sistema presenta, sul fronte e sul retro della base imbottita, una cornice curva in alluminio verniciato o spazzolato lucido, che protegge il rivestimento valorizzando al contempo l'intera silhouette.

A distinctive silhouette, characterised by overlapping rounded volumes with a clear 60s and 70s influence, brings the Coupé seating system by Giampiero Tagliaferri to life. The designer describes the project as "a seating experience that is both nostalgic and forward-thinking: we have reinterpreted classic forms through a contemporary lens, finding a balance between vintage charm and modern functionality". The reference to the aesthetics of 20th-century modernism is encapsulated in the soft forms, and in the precious couture-inspired details, such as the longitudinal stitching, intentionally tone-on-tone, featured in the leather version: an elegant graphic element, a mark of Minotti's refined craftsmanship, which runs along the entire volume, starting from the headrest, touching on the buttons on the backrest, and continuing across the seat. The enveloping shapes and ergonomic sinuosity of Coupé, delivered by the inclined seat specifically designed to ensure maximum comfort, intersect with the strong horizontality of the padded headrest and lumbar cushion elements, creating an engaging visual dynamism that culminates in the view of the armrest, highlighting the profile of the sofa.

"At the heart of this project lies a deep respect for the past, an homage to an era when sofas embraced the body with inclined seating, offering both aesthetic grace and unparalleled comfort", confirms Tagliaferri. Distinguished by a broad selection of options, the system can be used to create infinite flexible layouts, allowing for both the combination of seating elements and the use of individual pieces independently. Among them, a standout is the couch, with its generous proportions and unique double inclination. With its highly distinctive design, this system features a curved aluminium frame, either varnished or brushed polished, on the front and back of the upholstered base, not only protecting the upholstery, but also enhancing the entire silhouette.



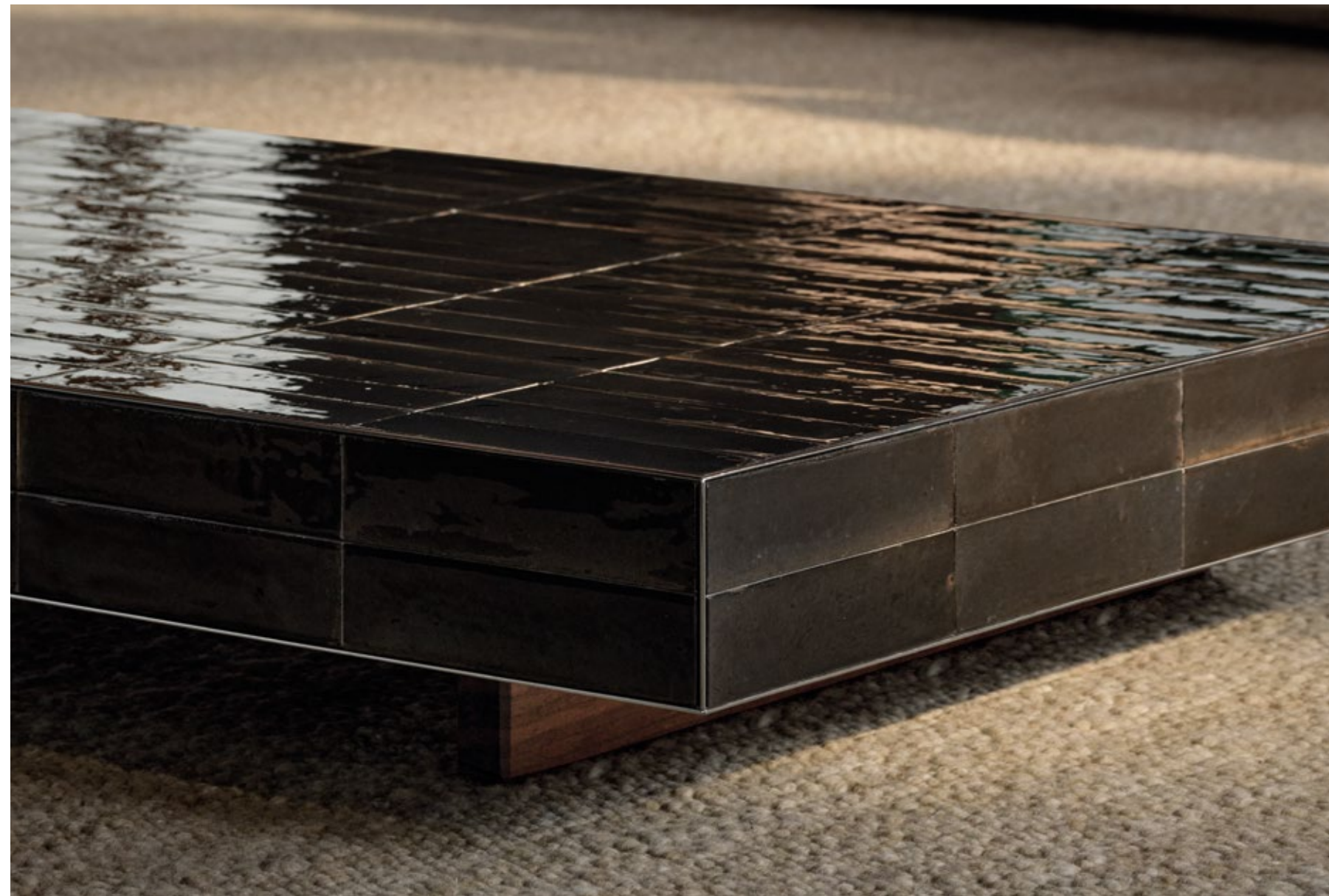







DIAGRAMMA HORIZONTAL SIDEBOARD | ZEALAND RUG





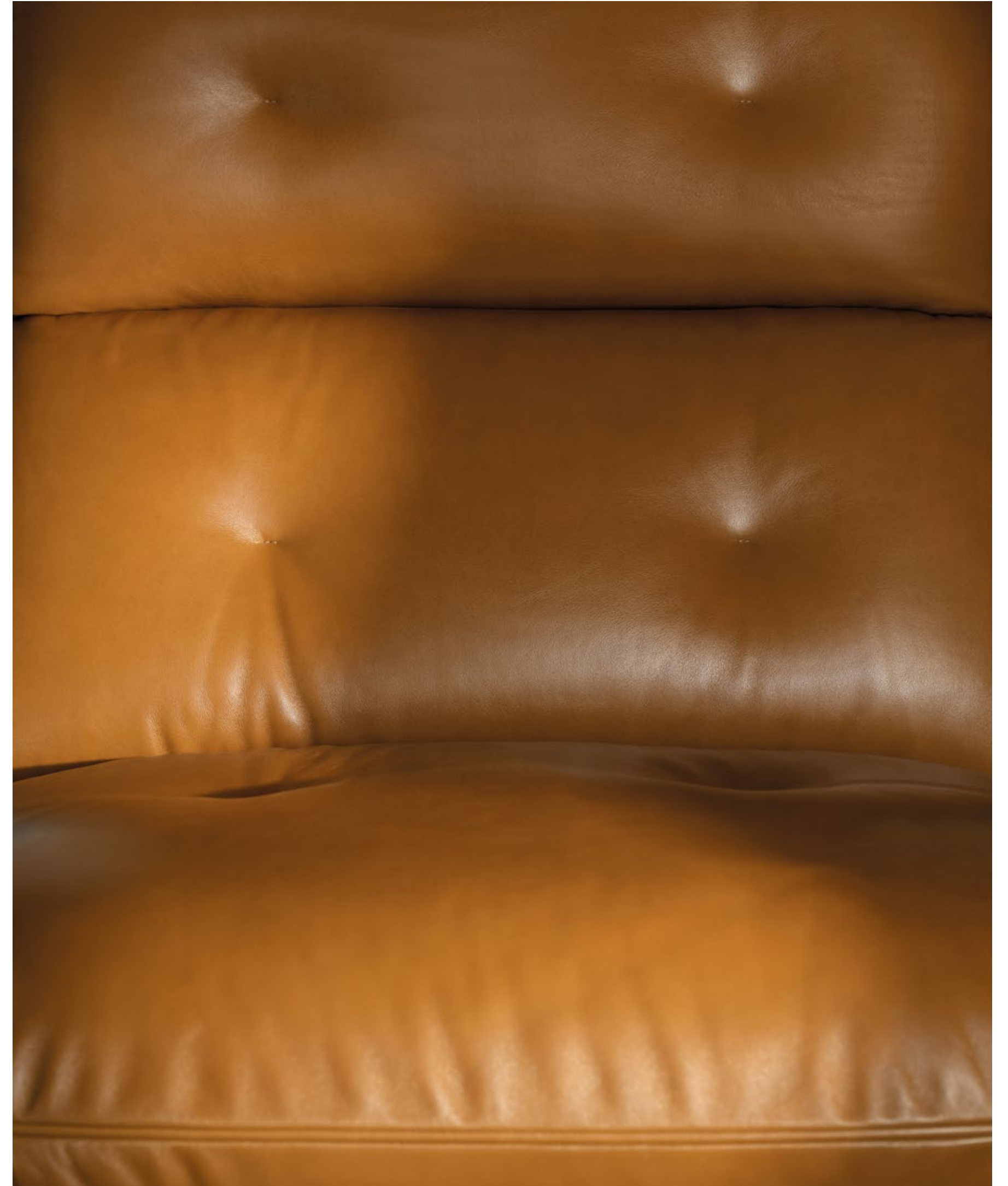
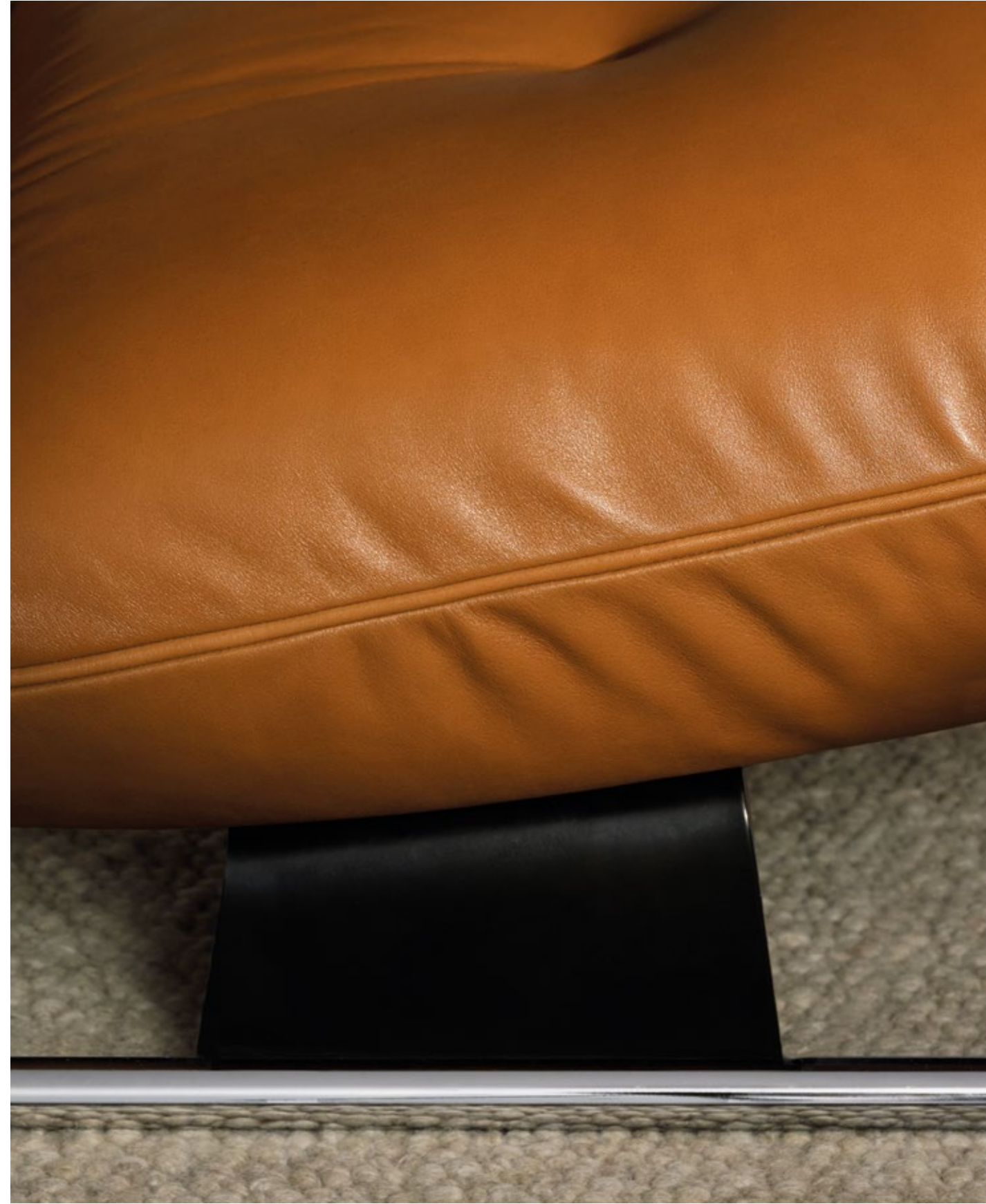









LIBRA BED, BED AND BENCH | ELLI NIGHT SIDEBOARD | ALPS RUG

"As the master Oscar Niemeyer said, the entire universe is made of curves."

BY MARCIO KOGAN / STUDIO MK27

Bézier





BÉZIER MODULAR SEATING SYSTEM AND OTTOMANS | BÉZIER COFFEE TABLES | FAIRWAY RUG



BÉZIER MODULAR SEATING SYSTEM AND OTTOMAN | BÉZIER COFFEE TABLES | ZOE BOOKCASE | FAIRWAY RUG

Islands of pure geometry

Il sistema di sedute Bézier si sviluppa attraverso elementi aggregabili dalle forme irregolari, organiche e sinuose, trasformando le curve in un'espressione di geometria pura. Come isole, i moduli di seduta sono pensati per trasformare il living in un'oasi di relax, dando vita a configurazioni versatili che si adattano agli spazi e alle esigenze dell'abitare contemporaneo.

The Bézier seating system consists of modular elements with irregular, organic and flowing shapes, turning curves into an expression of pure geometry. Like islands, the seating modules are designed to transform the living area into an oasis of relaxation, creating versatile configurations that adapt to both the spaces and the needs of contemporary living.

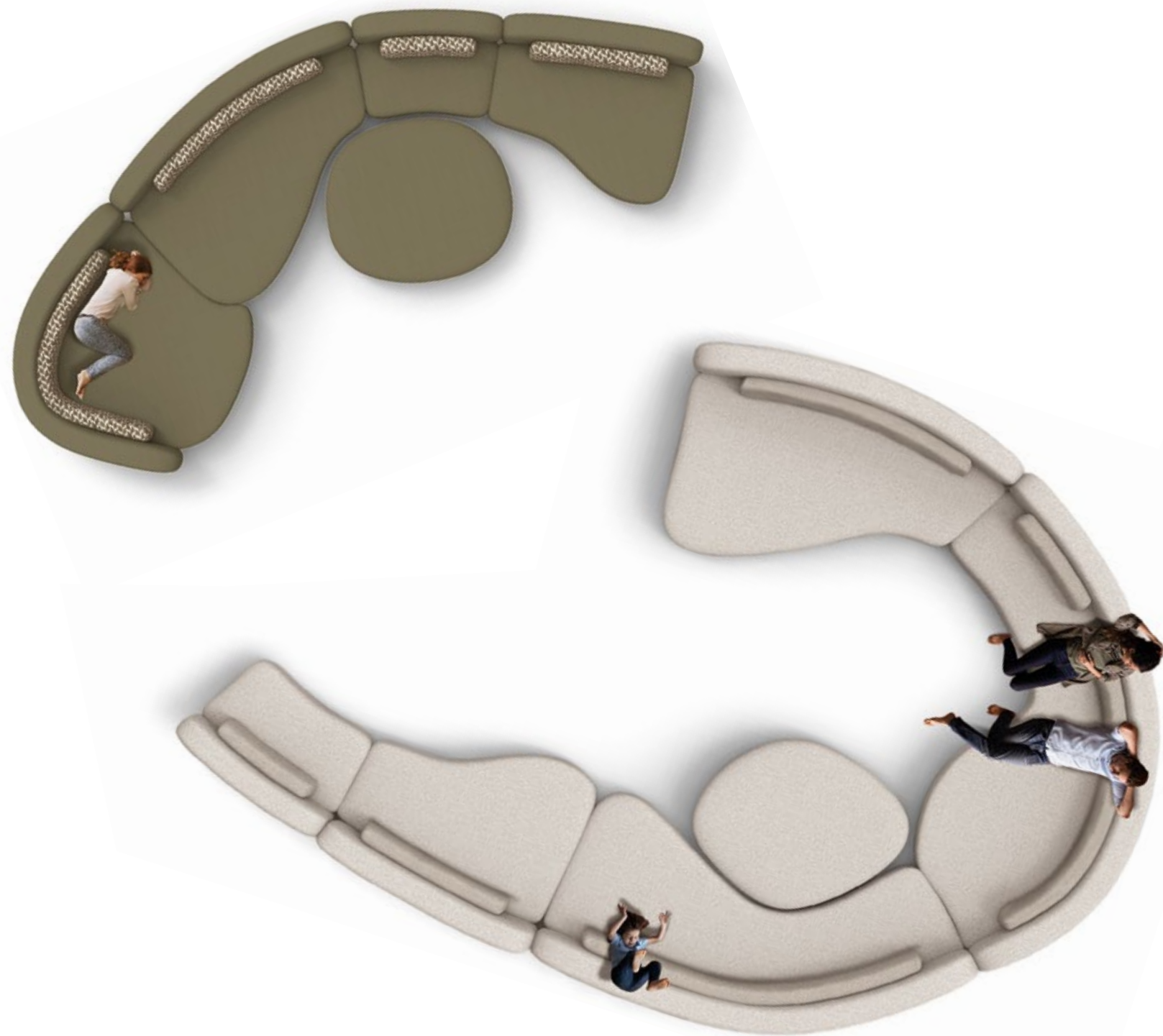

Inspirational configurations by Studio MK27

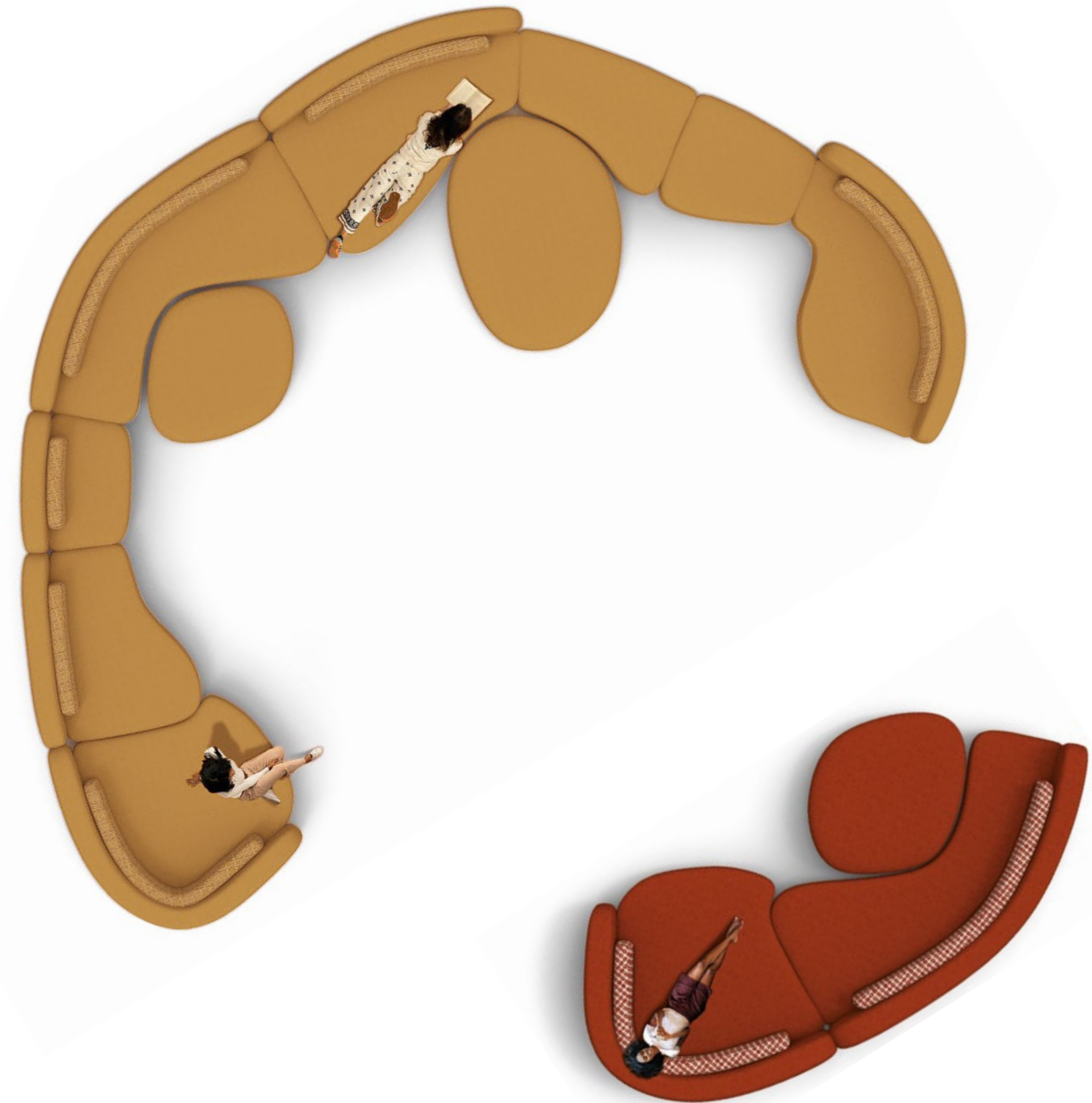

Discover the concept behind Bézier
Watch the video by Studio MK27



BÉZIER MODULAR SEATING SYSTEM AND OTTOMAN | LIBRA BERGÈRE AND FOOTSTOOL | ANDRÉE COFFEE TABLE | NASTRO SIDE TABLE | ZEALAND RUG











Ben oltre il concetto di divano, il sistema Bézier si connota come un insieme di sedute organiche e aggregabili all'infinito per composizioni sempre diverse e adattabili.

Firmato dallo Studio MK27, il cui fondatore Marcio Kogan ha fatto del rigore delle sue linee un tratto distintivo, Bézier sperimenta e interpreta un linguaggio compositivo inedito e di grande impatto, sviluppato con volumi irregolari e linee fluide che disegnano e abbracciano lo spazio e chi lo utilizza. "L'intero universo è fatto di curve" dice Kogan, citando il maestro Oscar Niemeyer.

E le curve del sistema Bézier sono enfatizzate dalla seduta estremamente confortevole e caratterizzata da una morbidezza ottenuta grazie all'accurata stratificazione di poliuretani a quote differenziate ad alta densità che permettono un comfort omogeneo su tutta la superficie. Trattandosi di forme organiche, la lavorazione sartoriale delle cuciture è estremamente accurata, seguendo alla perfezione le sinuosità degli elementi. Inoltre, collocato lungo tutto lo schienale, un cuscino poggiatesta conferisce ulteriore relax, diventando anche un motivo decorativo.

Il sistema Bézier è un omaggio alla fusione tra matematica e arte, ispirata all'eredità di Pierre Bézier, la cui famosa curva parametrica, spesso usata in computer grafica, celebra la precisione e la fluidità delle forme organiche. Questo sistema di sedute dalla grande versatilità, con le sue ampie forme che si espandono fino a diventare isole, permette di creare nuovi modi di vivere il living, non solo in ambienti domestici, ma anche Hospitality: un'innovativa modalità di approcciarsi al divano che da oggetto si trasforma in luogo di incontro e di aggregazione.

Come è caratteristico del DNA di Studio MK27, la collezione Bézier rende omaggio al modernismo brasiliano e celebra la libertà della curva come soluzione della natura: emozione e funzionalità in perfetto equilibrio.

Far beyond the concept of a traditional sofa, the Bézier system is defined by a series of organic, infinitely combinable seating elements, allowing for endlessly adaptable configurations.

Designed by Studio MK27, whose founder Marcio Kogan has made the precision of his lines into a distinctive hallmark, Bézier explores and reinterprets a novel and striking compositional language. It is developed through irregular volumes and fluid forms that shape and embrace both the space and those who inhabit it. "The entire universe is made of curves", says Kogan quoting the master Oscar Niemeyer.

And the curves of the Bézier system are enhanced by its exceptionally comfortable seat, achieved through the precise layering of high-density polyurethane in varying thicknesses, ensuring uniform comfort across the entire surface. Given the organic shapes, the tailoring of the seams is extremely accurate, perfectly following the curves of each element. Furthermore, located all along the backrest, a lumbar cushion provides greater relaxation while also serving as a decorative element.

The Bézier system is a tribute to the fusion of mathematics and art, inspired by the legacy of Pierre Bézier, whose famous parametric curve, often used in computer graphics, celebrates the precision and fluidity of organic shapes. Highly versatile, with its generous forms that stretch to become islands, it creates new ways to experience the living space, not only in home environments, but also in Hospitality settings. It is an innovative approach to the sofa, transforming it from a mere object into a place of meeting and gathering.

As is characteristic of the DNA of Studio MK27, the Bézier collection pays tribute to Brazilian modernism and celebrates the freedom of the curve as a solution inspired by nature: emotion and functionality in perfect balance.

































“This dynamic and versatile seating system interprets the embrace of two perfectly complementary elements, balanced between restraint and expressiveness, rigour and ease, permanence and fluidity. One is distinctly architectural, outward-facing, while the other is softer on the interior, featuring a strong decorative sign that extends an invitation to relax.”

BY HANNES PEER

Riley



Un motivo geometrico sinuoso definisce l'identità del sistema di sedute Riley di Hannes Peer. Dall'estetica senza tempo, espressione tipica del linguaggio stilistico Minotti, l'architetto la definisce come "una seduta dinamica e flessibile che interpreta l'abbraccio di due anime perfettamente complementari in equilibrio tra compostezza ed espressività, rigore e naturalezza, solidità e fluidità: una prima, che coincide con l'esterno del volume dello schienale, marcatamente architettonico, e una seconda all'interno, più morbida, caratterizzata da un forte segno decorativo, che invita ad accomodarsi."

Dallo zoccolo metallico arretrato, il volume della seduta a pozzetto si innalza monolitico e solido, arricchito da leggere trapuntature verticali che ritmano schienale e bracciolo, mentre un profilo più profondo, rivestito in pelle, a contrasto o in abbinamento cromatico al rivestimento scelto per il divano, diventa il tratto distintivo del progetto. Una traccia, una linea continua, curva e retta, che accarezza lo schienale squadrato e il bracciolo fino a disegnare un taglio a goccia con inclinazione a 45 gradi in corrispondenza dell'angolo tra il bracciolo e il sedile, trasformando il divano in un inedito oggetto couture. La cuscineria della seduta è intera, accolta parzialmente nella base imbottita e impreziosita da una fascia di 5 cm. La possibilità di avere elementi con due diverse profondità di seduta conferisce a questo sistema non solo maggiore comfort, ma anche un gioco interessante di volumi abbinabili tra loro.

I cuscini aggiuntivi "relax", invece, fungono da poggiatesta, grazie ad una struttura interna in alluminio multidirezionale modellabile a piacimento, completamente avvolta da una stratificazione sofisticata di poliuretani, capace di conferire il massimo comfort.

In aggiunta, la ricca gamma cromatica delle finiture possibili per il rivestimento del profilo cucito, oltre che la confezione ricercata, contribuiscono a rendere Riley un arredo esclusivo e unico nel suo genere nel suo classico rigore senza tempo.

A sinuous geometric pattern defines the identity of the Riley seating system by Hannes Peer. With a timeless aesthetic, characteristic of Minotti's stylistic language, it is defined by the architect as "a dynamic and versatile design that interprets the embrace of two perfectly complementary souls, balanced between restraint and expressiveness, rigour and ease, permanence and fluidity. One is distinctly architectural, outward-facing, while the other is softer on the interior, featuring a strong decorative sign that extends an invitation to relax".

From the recessed metal base, the volume of the seat rises monolithic and solid, enriched with light vertical quilting that gives rhythm to the backrest and armrest. Meanwhile, a deeper profile, upholstered in leather in contrast or colour-matched to the upholstery chosen for the sofa, becomes the distinctive feature of the design. A trace, a continuous line, both curved and straight, that follows the square backrest and armrest, creating a teardrop-shaped cut with a 45-degree inclination at the junction between the armrest and the seat, transforming the sofa into a unique couture-inspired piece. The seat cushion is a single element, partially housed in the padded base, and enhanced with a 5 cm-wide decorative band. The possibility to have elements with two different seat depths not only adds greater comfort to this system but also creates an interesting interplay of volumes that can be combined.

The additional "relax" cushions, on the other hand, serve as headrests, thanks to an internal, multidirectional aluminium frame that can be shaped as desired, fully enveloped in a sophisticated layering of polyurethanes, offering maximum comfort.

In addition, the wide range of colour finishes available for the stitched profile, along with the exquisite craftsmanship of the upholstery, help make Riley an exclusive and refined piece, one of a kind in terms of its timeless, classic elegance.





RILEY MODULAR SEATING SYSTEM | ANDRÉE COFFEE TABLES | LIBRA HORIZONTAL SIDEBOARD | ZEALAND RUG





RILEY MODULAR SEATING SYSTEM | STAGE SIDE TABLE | ANDRÉE SIDE TABLE | ZEALAND RUG















RILEY MODULAR SEATING SYSTEM | STAGE SIDE TABLE | ALPS RUGS







The “Relax” cushion

Il cuscino addizionale “Relax” funge da poggiatesta, grazie ad una struttura interna in alluminio multidirezionale modellabile a piacimento, completamente avvolta da una stratificazione sofisticata di poliuretani, capace di conferire il massimo comfort. La possibilità di avere elementi con due diverse profondità di seduta, inoltre, conferisce a questo sistema non solo maggiore comfort, ma anche un gioco interessante di volumi abbinabili tra loro.

The additional “Relax” cushion serves as headrest, thanks to an internal, multidirectional aluminium frame that can be shaped as desired, fully enveloped in a sophisticated layering of polyurethanes, offering maximum comfort. Furthermore, the possibility to have elements with two different seat depths, not only adds greater comfort to this system, but also creates an interesting interplay of volumes that can be combined.













The decorative sign

Un profilo realizzato in pelle, dal motivo geometrico sinuoso, definisce l'estetica di ispirazione couture del sistema di sedute Riley. Un forte segno grafico che, come una linea continua, scandisce la silhouette dello schienale squadrato e dell'intero perimetro del bracciolo, disegnando un taglio a goccia con inclinazione a 45 gradi in corrispondenza dell'angolo tra il bracciolo e il sedile.

Un dettaglio sartoriale che esprime l'identità grafica e decorativa del sistema, personalizzandolo con stile: nella versione del divano interamente in tessuto, infatti, il profilo in pelle è disponibile sia a contrasto, ad accentuare l'esprit contemporaneo dell'imbottito, che nella medesima nuance cromatica, come da gamma cromatica disponibile nel catalogo Piping Riley; nella versione in pelle il profilo, in nuance o a contrasto, sarà nella stessa pelle scelta per il rivestimento.

A leather profile with a sinuous geometric pattern defines the couture-inspired aesthetics of the Riley seating system. A bold graphic element, like a continuous flowing line, traces the silhouette of the square backrest and the entire perimeter of the armrest, forming a teardrop-shaped cut with a 45-degree inclination at the junction between the armrest and the seat.

A tailored detail that expresses the system's graphic and decorative identity, personalising it with style. In the all-fabric version of the sofa, the leather profile is available either in a contrasting shade, highlighting the contemporary spirit of the piece, or in a matching colour nuance, selected from the Riley Piping catalogue. In the leather version the profile, in a tone-on-tone or contrasting colour, is in the same leather chosen for the upholstery.





RILEY MODULAR SEATING SYSTEM | YVES COFFEE TABLE | ALPS RUG



“A piece that plays with the harmony of shapes. Its soft and generous curves, typical of the Vivienne Large armchair, evolve into a sofa system with new proportions. A perfect balance between sinuosity and geometric rigour, between the decorative and the essential, making it suitable for any modern space while maintaining an iconic and organic character.”

BY GAMFRATESI

Vivienne













Dalla curva ad emiciclo dello schienale della poltrona Vivienne, nasce l'omonimo sistema di sedute dall'estetica contemporanea firmato dal duo di progettisti italo-danese GamFratesi. L'abbraccio dello schienale che avvolge la seduta diventa anche bracciolo, donando al divano un gusto particolarmente decorativo. Si tratta di un progetto caratterizzato da una base imbottita finemente sagomata, sostenuta da barre in alluminio arretrate, che accoglie e parzialmente cela lo spessore della cuscinatura che, alla vista, appare più sottile: un dettaglio che dona all'imbottito un aspetto più delicato, rendendolo leggero se pur estremamente comodo. I progettisti parlano di questo sistema di sedute come di "un pezzo che gioca con l'armonia delle forme. Le sue curve morbide e generose, tipiche della poltrona Vivienne Large, si evolvono in un sistema di divani dalle proporzioni nuove: un equilibrio perfetto tra sinuosità e rigore geometrico, tra il decorativo e l'essenziale, che lo rende adatto a qualsiasi ambiente moderno, pur mantenendo un carattere iconico e organico."

Vivienne è un sistema dalla grande versatilità compositiva, che oltre a divani, elementi terminali e chaise-longue, comprende anche elementi con piani d'appoggio, dando così vita ad originali combinazioni e creando uno stile coerente per ambienti di diverse dimensioni.

The Vivienne seating system is inspired by the semicircular curved backrest of the Vivienne armchair, featuring a contemporary aesthetic designed by Italian-Danish duo GamFratesi. The embrace of the backrest that wraps around the seat also acts as an armrest, giving it a particularly decorative flair. The project features a finely contoured upholstered base, supported by recessed aluminium bars, which hosts and partially conceals the thickness of the cushions. As a result, the seat appears thinner – a detail that gives the upholstery a more delicate look, making it feel light while remaining incredibly comfortable. The designers describe this seating system as "a piece that plays with the harmony of shapes. Its soft and generous curves, typical of the Vivienne Large armchair, evolve into a sofa system with new proportions. A perfect balance between sinuosity and geometric rigour, between the decorative and the essential, making it suitable for any modern space while maintaining an iconic and organic character."

Vivienne is a system that offers great compositional versatility, and, in addition to sofas, end pieces and chaise lounges, it also includes elements with tops, thus giving rise to original combinations and creating a cohesive style for spaces of different sizes.







































VIVIENNE OTTOMANS WITH TOP | TAIKO SIDE TABLE



VIVIENNE MODULAR SEATING SYSTEM | LIBRA ARMCHAIR | BÉZIER COFFEE TABLE | NASTRO SIDE TABLE | ZEALAND RUG

“The symbol of the bud lies in the subtle incisions made on the top of the cushion, at the corner, creating a well-balanced separation and cohesion, seamlessly transitioning from the backrest to the armrest.”

BY OKI SATO / NENDO

Saki



In Giappone il termine "Saki" indica la fioritura ed è proprio allo schiudersi dei boccioli che Nendo rende omaggio con una famiglia di sedute definite dalla presenza di sinuosi pannelli di sostegno per schienale e braccioli. Laccati in diverse nuance o rivestiti in tessuto o pelle, consentono di ottenere molteplici combinazioni, conferendo così un'estetica ricercata ed eclettica agli arredi.

Realizzata secondo un concept di aggregabilità, Saki è disponibile nelle varianti divano a 2, 3 o 4 posti con due diverse profondità, nella versione poltrona con e senza braccioli, panche ed originali isole disponibili in diverse configurazioni. Il sistema presenta ampie sedute dalla silhouette curvilinea, rifinite da un piping perimetrale che ne definisce elegantemente il profilo. Oki Sato interpreta il simbolo del bocciolo "nelle sottili incisioni praticate sulla parte superiore della cuscineria in corrispondenza dell'angolo, che creano una separazione e una coesione ben equilibrate, passando senza soluzione di continuità dallo schienale al bracciolo." Un movimento leggero e sinuoso che si traduce in un comfort avvolgente e protettivo, dato anche dalla morbidezza dei cuscini con struttura interna sagomata, frutto di un'attenta progettazione ergonomica. La declinazione a isola quadrata, la cui superficie è arricchita da cuciture che si incrociano al centro, è particolarmente accogliente e può rivelarsi una spaziosa seduta sulla quale sdraiarsi o accomodarsi in più persone lungo il suo perimetro, in spazi lounge, domestici o Hospitality. Oltre alle sue caratteristiche sartoriali, è impreziosita da piedi curvilinei in alluminio dall'estetica dinamica, presenti anche in tutti gli altri elementi della famiglia. La poltrona è disponibile anche con un ulteriore appoggio a terra costituito da una base quadrata con angoli stondati, sia nella versione girevole che fissa.

In Japan, the term "Saki" means blooming, and it is precisely to the unfolding of flower buds that Nendo pays tribute with a family of seats, characterised by the presence of sinuous support panels for the backrest and armrests. These panels can be lacquered in various shades or upholstered in fabric or leather, allowing for endless combinations, giving each furnishing piece a refined and eclectic aesthetic.

Based on a concept of modularity, Saki is available in 2-, 3-, or 4-seat sofa versions with two different depths, in an armchair version with or without armrests, in benches and in original island-like elements, available in various configurations. The system features large seats with a curvilinear silhouette, embellished with a perimeter piping that elegantly defines its profile. Oki Sato interprets the symbol of the bud "in the subtle incisions made on the top of the cushion, at the corner, creating a well-balanced separation and cohesion, seamlessly transitioning from the backrest to the armrest." A light and sinuous movement, translating into an enveloping and protective comfort, further enhanced by the softness of the cushions featuring a moulded internal structure, the result of meticulous ergonomic design. The square island version, whose surface is enriched with stitching that intersects at the centre, is particularly inviting and can be used as a spacious seating area where multiple people can lie out or sit along its perimeter, in lounge, residential, or Hospitality spaces. In addition to its tailored features, it is enhanced by curvilinear aluminium feet with a dynamic aesthetic, also used for all the other elements in the family. The armchair is also available with an additional floor support consisting of a square base with rounded corners, in both swivel and fixed versions.









SAKI MODULAR SEATING SYSTEM | BÉZIER COFFEE TABLE | NASTRO SIDE TABLE | FAIRWAY RUG

















SAKI DINING TABLE | TAPE DINING LITTLE ARMCHAIRS | FAIRWAY RUG





SAKI DINING TABLE | TAPE DINING LITTLE ARMCHAIRS





Outdoor Collection



Bézier Cord Outdoor

MARCIO KOGAN / STUDIO MK27 DESIGN









BÉZIER.CORD.OUTDOOR MODULAR SEATING SYSTEM AND OTTOMAN | BÉZIER.OUTDOOR COFFEE TABLE | AVERY RUG

Con i suoi volumi avvolgenti, il sistema di sedute Bézier Cord Outdoor disegna nuovi landscape open-air attraverso configurazioni originali e inaspettate.

Progettato dallo Studio MK27 ed ispirato dalla geometria della curva parametrica del matematico Bézier, matrice dell'omonima versione indoor, questo sistema esplora un inedito linguaggio compositivo di grande impatto: caratterizzato da volumi irregolari dall'estetica dinamica e da linee sinuose che avvolgono lo spazio, possono essere utilizzati in aggregazione tra loro o come elementi singoli, instaurando un dialogo intimo ed armonico con chi lo vive. Bézier Cord Outdoor si connota con una struttura dello schienale in tubolare di alluminio verniciato, avvolto longitudinalmente da un intreccio di corda in polipropilene dal forte spessore, e rifinito alle estremità da una piastra in alluminio verniciata in nuance con la corda.

La seduta monoblocco estremamente confortevole è caratterizzata da una morbidezza ottenuta grazie all'attenta stratificazione di poliuretani a quote differenziate ad alta densità che conferiscono un comfort omogeneo su tutta la superficie. Trattandosi di forme organiche, la lavorazione sartoriale delle cuciture è estremamente puntuale, seguendo meticolosamente le sinuosità degli elementi. La seduta profonda e generosa è sollevata da terra grazie a piedini arretrati in acciaio inox verniciati in tonalità testa di moro, rendendo questo sistema ideale tanto per contesti formali quanto per momenti di puro relax.

Characterized by enveloping volumes, the Bézier Cord Outdoor seating system designs new open-air landscapes through original and unexpected configurations.

Designed by Studio MK27 and inspired by the geometry of the parametric curve of the mathematician Bézier, which is the matrix of its indoor counterpart, this system explores a unique, powerful compositional language: characterised by irregular volumes, dynamic aesthetic and sinuous lines that embrace the space, the elements can be used together in various combinations or as standalone pieces, establishing an intimate and harmonious dialogue with those who experience them.

Bézier Cord Outdoor features a painted tubular aluminium backrest structure, wrapped longitudinally in a thick polypropylene cord weave, and finished at the ends with an aluminium plate in a nuance that matches the cord.

The exceptionally comfortable one-piece seat is defined by its softness, achieved as a result of the careful layering of high-density polyurethane foams with varying thicknesses, ensuring uniform comfort across the entire surface. Given the organic shapes, the tailoring of the stitching is extremely precise, meticulously following the curves of each element. The deep and generous seat is elevated off the ground thanks to the recessed stainless steel feet in dark brown, making Bézier Cord Outdoor ideal for both formal settings and moments of pure relaxation.











BÉZIER CORD OUTDOOR MODULAR SEATING SYSTEM AND OTTOMAN | BÉZIER OUTDOOR COFFEE TABLES | TRICOT RUG















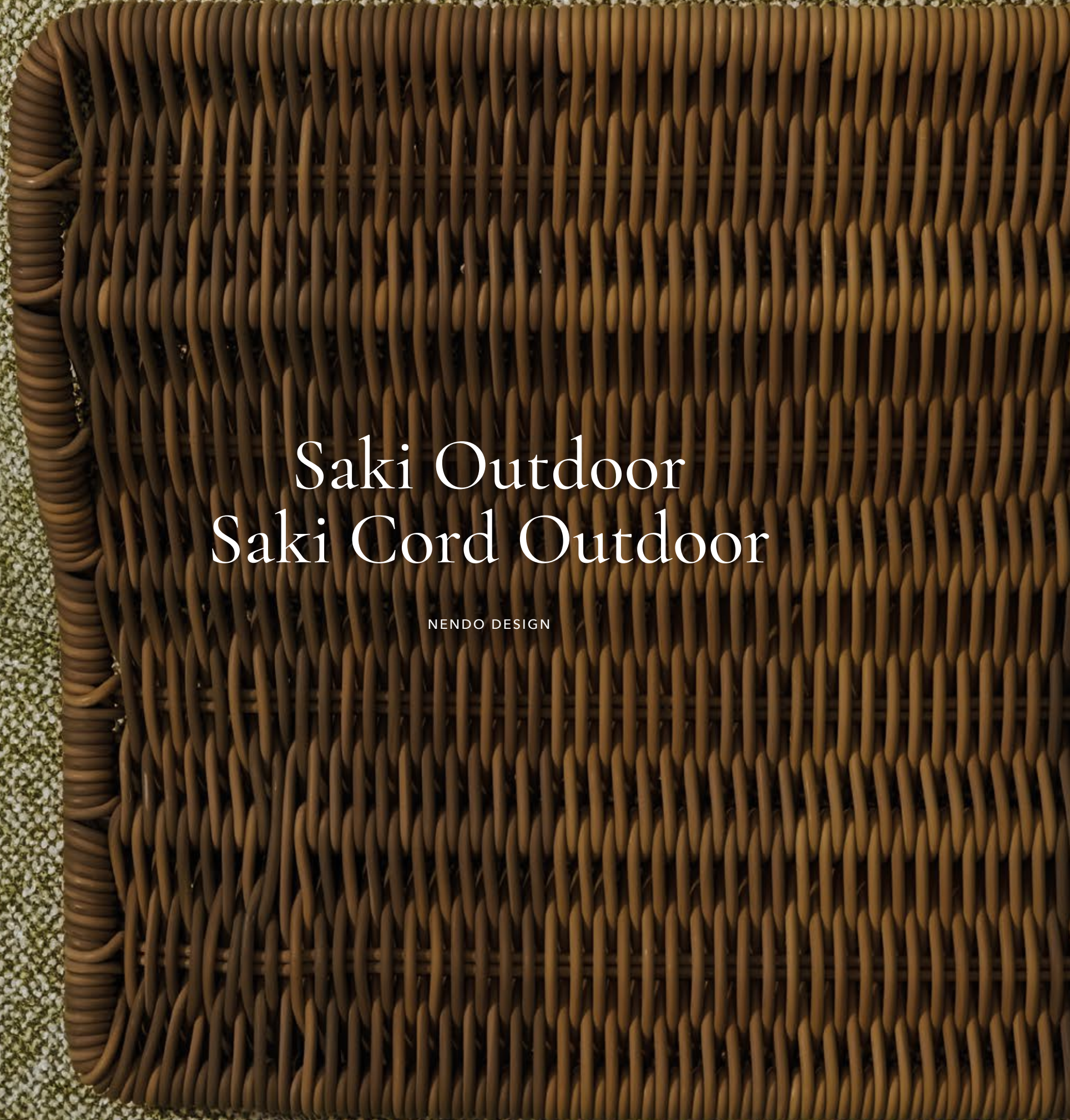
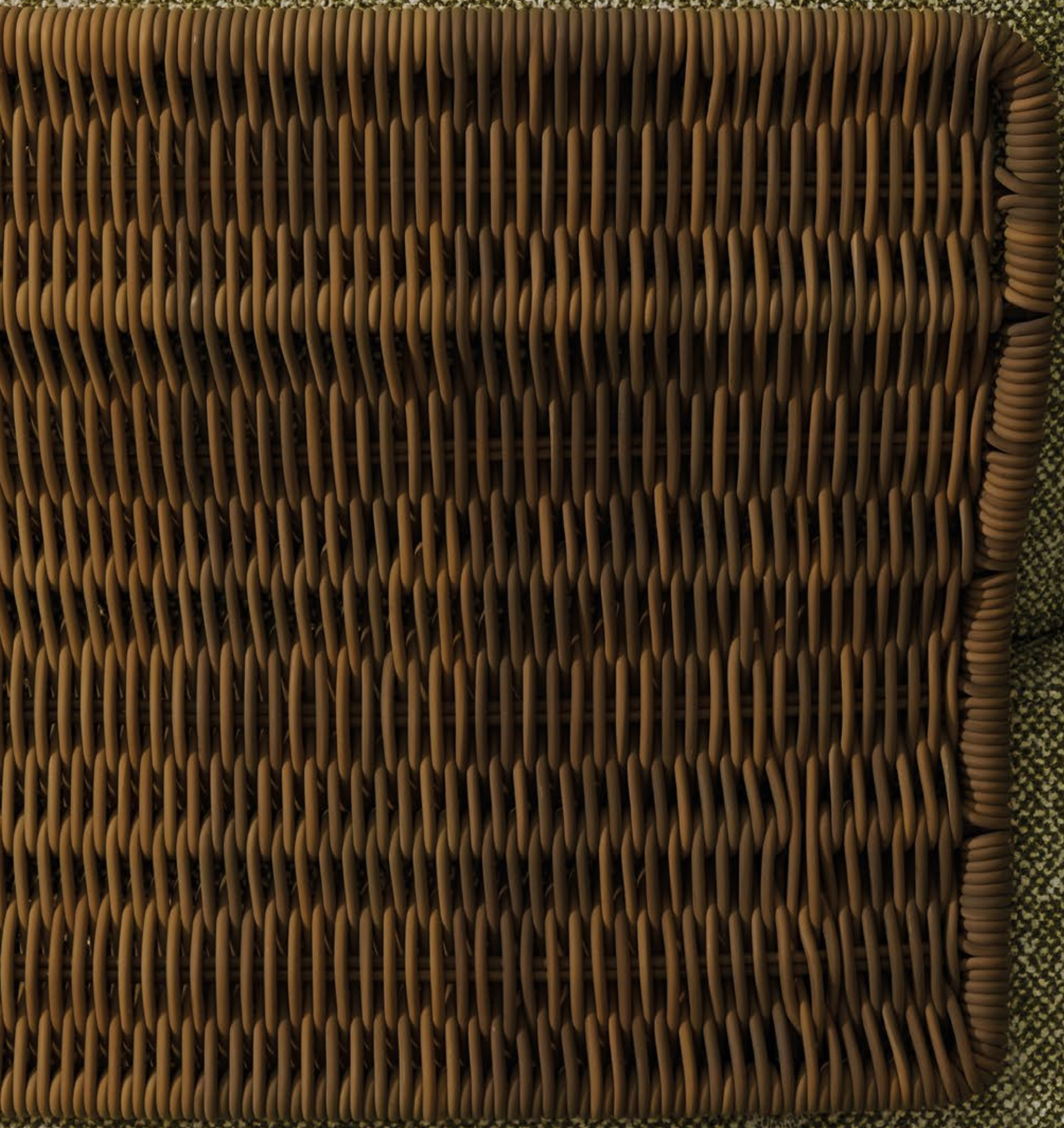

Saki Outdoor
Saki Cord Outdoor

NENDO DESIGN





La versione per gli spazi open-air dell'organico sistema di sedute indoor Saki progettato da Nendo è prevista nelle declinazioni con sinuosi pannelli laccati, Saki Outdoor, oppure con pannelli caratterizzati da un intreccio incordato ad effetto midollino, Saki Cord Outdoor: entrambe le famiglie di sedute sono disponibili in un'ampia varietà di finiture che consentono di ottenere svariate combinazioni, conferendo così agli arredi un'estetica sofisticata e dalla forte personalità.

Con la forma sinuosa dei pannelli di schienali e braccioli, Nendo richiama l'immagine della fioritura, in giapponese Saki, da cui prende il nome questo sistema. La seduta morbida offre un comfort estremo, ulteriormente enfatizzato da avvolgenti cuscini schienale, delicatamente appoggiati sulle pannellature a petalo.

Anche la versione outdoor, perfettamente coerente al concept di aggregabilità, dispone delle varianti divano a 2, 3 o 4 posti, elementi con due diverse profondità, poltrona con e senza braccioli, panche ed originali isole particolarmente accoglienti disponibili in diverse configurazioni, previste sia con piedi fissi curvilinei che con base girevole.

Il sistema presenta sedute generose dalla silhouette morbida e arrotondata, rifinite da un piping perimetrale che ne disegna elegantemente i volumi. Il dettaglio sartoriale praticato sulla parte superiore della cuscineria angolare scandisce i profili degli imbottiti, creando una separazione e una coesione ben equilibrate. Anche i piedi curvilinei in pressofusione di alluminio verniciato peltro si adeguano perfettamente all'estetica avvolgente e sinuosa.

The open air version of the organic Saki indoor seating system, designed by Nendo, is available with sleek lacquered panels, Saki Outdoor, or with panels featuring a wicker-effect woven cord design, Saki Cord Outdoor: both seating families offer a wide variety of finishes, and can be combined to give the furnishing pieces a sophisticated aesthetic and a strong personality.

Thanks to the sinuous shape of the backrest and armrest panels, Nendo evokes the image of blooming flowers, or "Saki" in Japanese, from which the system takes its name. The soft seat offers extreme comfort, further emphasised by enveloping back cushions, gently resting on the petal-shaped panels.

The outdoor version, perfectly consistent with the concept of modularity, offers 2, 3, or 4-seat sofa variants, elements in two different depths, armchairs with and without armrests, benches and original, particularly cosy islands conceived in different configurations, both presenting fixed curved feet or swivel bases.

The system features generous seating with a soft, rounded silhouette, finished with a perimeter piping that elegantly defines its volumes. The tailoring detail on the top of the corner cushion accentuates the profiles of the upholstery, creating a well-balanced separation and cohesion. The curved feet, in die-cast aluminium, pewter varnished, perfectly complement the enfolding and sinuous aesthetic.















SAKIOUTDOOR MODULAR SEATING SYSTEM | ANDRÉE OUTDOOR COFFEE TABLE AND SIDE TABLE



Emmi Cord Outdoor

HANNES PEER DESIGN

Progettata da Hannes Peer per l'indoor, Emmi si declina anche per il living all'aperto dando vita ad una poltrona e ad un divano che richiamano l'elegante estetica degli arredi outdoor anni '70, con forme ampie e accoglienti. Realizzata per vivere nei più svariati contesti outdoor, l'esile struttura metallica in tubolare rivestita con intreccio in corda nella medesima nuance, ospita i morbidi cuscini di seduta e schienale. La sua base, dall'originale silhouette sinuosa, disegna come una linea continua la seduta e lo schienale, donando all'arredo una sofisticata leggerezza visiva che lo rende più aereo.

Designed by Hannes Peer for indoor spaces, Emmi is also adapted for open-air living, giving rise to an armchair and a sofa that evoke the elegant aesthetic of 1970s outdoor furnishing pieces, with generous and inviting shapes. Created to thrive in a wide variety of settings, the slender tubular metal frame, covered with woven cord in the same colour, supports the soft seat and back cushions. Its base, with its original sinuous silhouette, draws a continuous line between the seat and backrest, giving the furnishing piece a sophisticated visual lightness that makes it feel more weightless.





EMMI CORD OUTDOOR SOFAS AND ARMCHAIRS | ANDRÉE OUTDOOR COFFEE TABLE AND SIDE TABLE | BRAID RUG



Indoor textile and leather collection

La nuova 2025 Textile and Leather Collection è nata da un accurato studio in ambito stilistico e tecnologico, riflettendo un'evoluzione nel comfort, nella funzionalità e nell'estetica. Essa contribuisce a interpretare i nuovi scenari dell'abitare contemporaneo, offrendo un'ampia gamma di tessuti e pelli inediti dalla marcata forza espressiva, che richiamano i tratti, le geometrie o le trame materiche ispirate al gusto Anni '70, rilette in chiave contemporanea. La 2025 Textile and Leather Collection introduce tessuti con trame tridimensionali, pelli scamosciate e pelli all'anilina cerate, con profondità cromatiche uniche che danno vita a texture capaci di creare esperienze visive e tattili sempre più ricche e sensuali. Questa fusione materica e stilistica, pensata per incontrare sensibilità estetiche diverse, consente di conferire personalità ed eclettismo ai più svariati ambienti domestici contemporanei, oggi sempre più mutevoli e aperti alla personalizzazione.

Come sempre, un'attenzione particolare è riservata ai dettagli sartoriali e alla produzione interamente Made in Italy, con finiture che esaltano le linee degli arredi e garantiscono comfort e adattabilità. Le composizioni e i colori, ideati e ingegnerizzati dall'Ufficio Stile di Minotti, sono frutto di una profonda sperimentazione e ricerca interna all'azienda. Questi rivestimenti sono capaci di diventare un unicum con gli arredi, dando forma a un progetto in assoluta coerenza stilistica con il design di prodotto.

Grazie a un'attenta selezione di produttori di altissima qualità manifatturiera e delle relative supply chain, i tessuti e le pelli realizzati in esclusiva per il brand non solo rispondono a parametri qualitativi altissimi, ma anche a una comprovata durabilità e messa a punto tecnica. I materiali e le tecniche impiegate rappresentano l'ideale combinazione di sperimentazione e artigianalità, con fibre naturali e di recupero lavorate in modo tradizionale come cotone biologici, viscose, lini e pelli: la valorizzazione di talune lavorazioni artigianali ha permesso di arricchire la collezione con rivestimenti di alta manifattura, sempre nel rispetto degli standard di performance che Minotti garantisce da sempre.

The new 2025 Textile and Leather Collection is the results of a careful stylistic and technological research, reflecting an evolution in comfort, functionality and aesthetics. It helps interpret the new scenarios of contemporary living, offering a wide range of novel fabrics and leathers with strong expressive power, recalling the lines, geometries and tactile textures of the 1970s, reinterpreted in a contemporary key.

The 2025 Textile and Leather Collection introduces fabrics with three-dimensional textures, suede leathers and aniline-dyed waxed leathers, featuring unique chromatic depths that bring to life textures capable of creating increasingly rich and sensual visual and tactile experiences. This material and stylistic fusion, designed to cater to diverse aesthetic sensibilities, allows for the infusion of personality and eclecticism into today's variety of home environments, today increasingly dynamic and open to personalisation.

As always, special attention is paid to sartorial details and the entirely Made in Italy production, with finishes designed to enhance the lines of the furnishing pieces and ensure comfort and adaptability. The compositions and colours, conceived and engineered by the company's Style Department, are the result of in-depth experimentation and detailed in-house research. These coverings can become a unicum with the furnishing pieces, shaping a project in perfect stylistic coherence with the product design.

Thanks to a careful selection of highest quality manufacturers and their supply chains, the fabrics and leathers created exclusively for the brand not only meet the highest quality standards, but also offer proven durability and technical finalization.

The materials and techniques used represent the ideal combination of experimentation and craftsmanship, with natural and reclaimed fibres processed using traditional methods like organic cottons, viscoses, linens and leathers.

The enhancement of certain artisanal techniques has enriched the Collection with high-quality coverings, always in compliance with the excellent performance levels that Minotti has always guaranteed.

MONTEREY ART 43 (CAT. H)



SIERRA ART 43 (CAT. H)



LAKE ART 43 (CAT. G)



NEVADA ART 42 (CAT. G)



TRINITY ART 42 (CAT. G)



FREEMONT ART 42 (CAT. G)



PRASLIN BIG ART 42 (CAT. ALCANTARA)

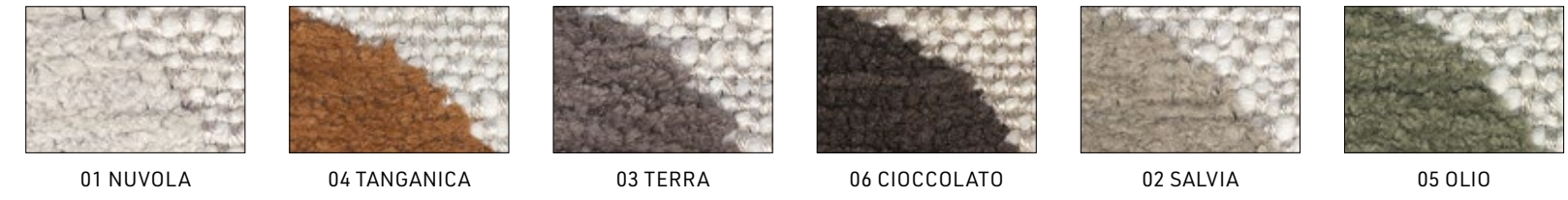

PRASLIN SMALL ART 42 (CAT. ALCANTARA)

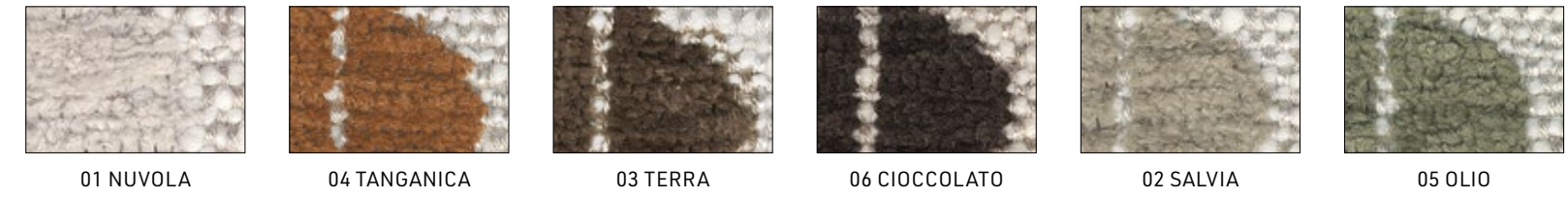

CARMEL BIG SUR - CARMEL LEATHER (CAT. PELLE NATURE)

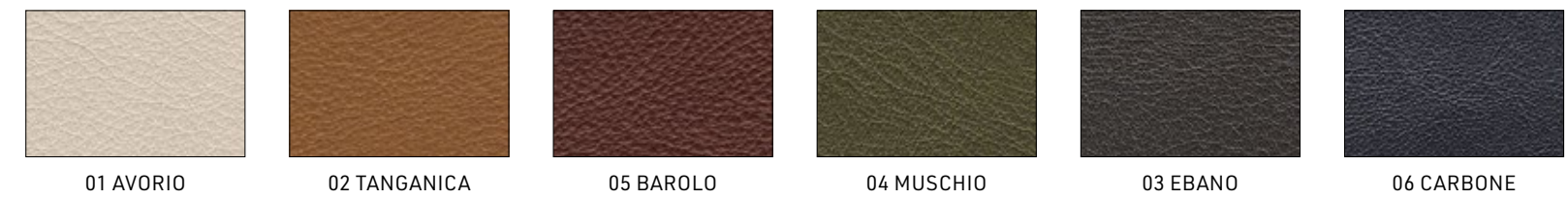

BIG SUR BIG SUR - CARMEL LEATHER (CAT. PELLE NATURE)

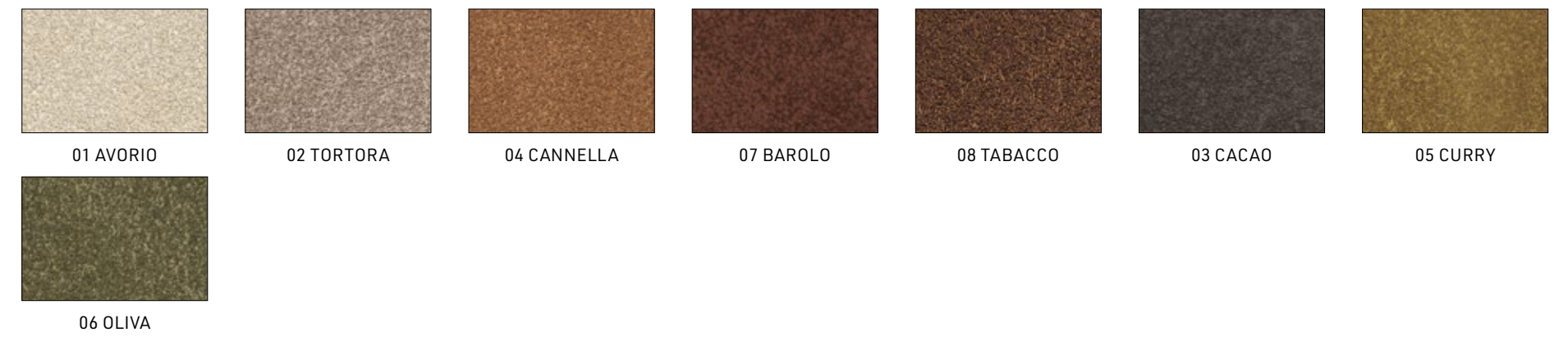

Outdoor textile collection

La 2025 Outdoor Textile Collection attinge all'expertise e all'inconfondibile stile del brand per spingersi nell'esplorazione di nuovi orizzonti creativi tra forme, immaginari e rievocazioni culturali: una proposta progettata per offrire soluzioni open-air avvolgenti e ricercate che coniugano comfort e funzionalità, design innovativo e materiali di alta qualità, e che richiamano l'eleganza senza tempo del modernismo.

Tutti i tessuti outdoor proposti da Minotti sono realizzati con i migliori filati, selezionati sulla base del loro pregio e delle loro caratteristiche tecniche, secondo i più evoluti standard qualitativi e prestazionali, vantando le più rigorose certificazioni in materia di sostenibilità e sicurezza senza mai compromettere l'eleganza.

Una collezione che raccoglie fibre morbide e resistenti agli agenti atmosferici, alle sollecitazioni meccaniche e al fuoco, anallergiche, riciclabili e intrecciate per dar forma a rivestimenti per esterni che si distinguono per raffinatezza e gusto impeccabili, lavorate secondo le tecniche più avanzate e su telai di ultima generazione.

Ispirati alla tradizione, filati come la ciniglia o lavorazioni di derivazione sartoriale come il bouclé divengono i tratti distintivi della nuova Outdoor Textile Collection che si arricchisce di nuance brillanti e accattivanti, progettate ed ingegnerizzate con meticolosa cura, per impreziosire e infondere sofisticatezza a giardini, terrazze e rooftop.

The 2025 Outdoor Textile Collection draws on the brand's expertise and unmistakable style to explore new creative horizons through shapes, imagery, and cultural references. A proposal designed to offer immersive and refined open-air solutions combining comfort and functionality, innovative design, and high-quality materials, while evoking the timeless elegance of modernism.

All the outdoor fabrics offered by Minotti are crafted with the finest yarns, selected for their value and technical features, according to the highest performance and quality standards, boasting the strictest sustainability and safety certifications, without ever compromising on elegance.

A collection that brings together soft, weather-resistant, mechanically durable, fireproof, hypoallergenic, and recyclable fibres, woven to shape outdoor coverings that stand out for their refinement and impeccable taste, processed using cutting-edge techniques and the latest-generation looms.

Inspired by tradition, yarns like chenille and tailoring-derived techniques such as bouclé define the new Outdoor Textile Collection, which is enriched with vibrant, captivating nuances, designed and engineered with meticulous care to embellish and infuse gardens, terraces, and rooftops with sophistication.

ANTIGUA ART LIFESCAPE 13 (CAT. H)



MUSTIQUE ART LIFESCAPE 13 (CAT. H)



HAITI ART LIFESCAPE 13 (CAT. ALCANTARA)

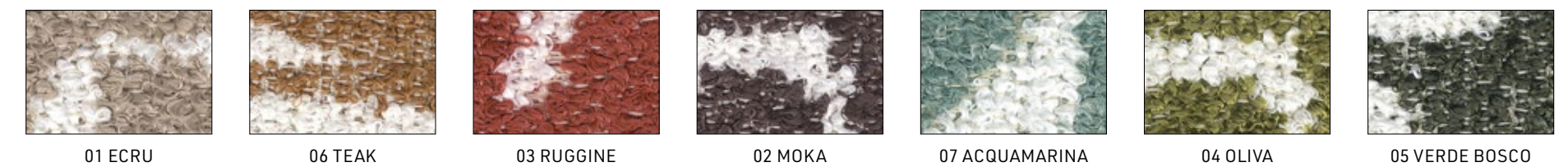

Technical data

COUPÉ

GIAMPIERO TAGLIAFERRI DESIGN



PANORAMICA | OVERVIEW

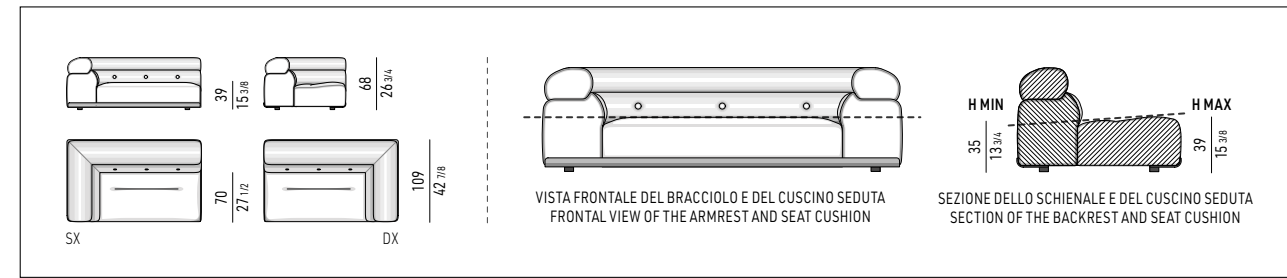

ALTEZZA PIEDINI | FEET HEIGHT

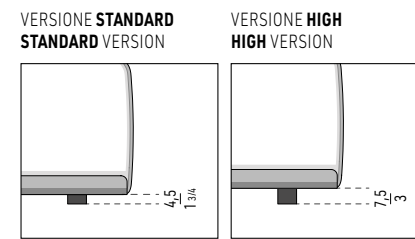

DIVANI | SOFAS

DIVANO CM 296 - 268 - 240
SOFA CM 296 - 268 - 240

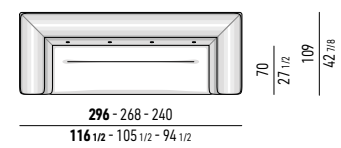

ELEMENTI TERMINALI | ELEMENTS WITH 1 ARMREST

ELEMENTO TERMINALE CM 263 - 235 - 207 - 179 - 151 - 123 - SX/DX
ELEMENT WITH 1 ARMREST CM 263 - 235 - 207 - 179 - 151 - 123 - SX/DX

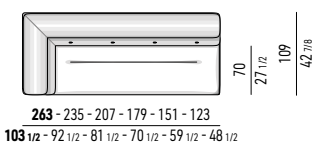

ELEMENTI CENTRALI | CENTRAL ELEMENTS

ELEMENTO CENTRALE CM 230 - 202 - 174 - 146 - 118 - 90
CENTRAL ELEMENT CM 230 - 202 - 174 - 146 - 118 - 90

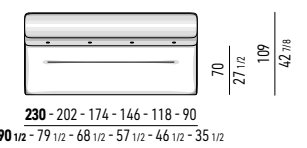

ELEMENTI ANGOLARI | CORNER ELEMENTS

ELEMENTO ANGOLARE CM 151X151 - 109X109 - SX/DX
CORNER ELEMENT CM 151X151 - 109X109 - SX/DX

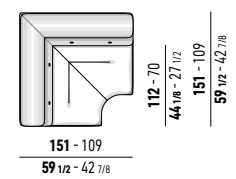

DIVANI ANGOLARI | CORNER SOFAS

DIVANO ANGOLARE CM 207X151 - 179X151 - SX/DX
CORNER SOFA CM 207X151 - 179X151 - SX/DX

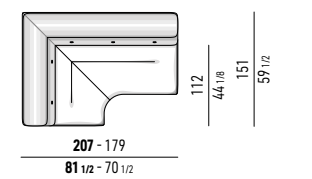

DIVANO ANGOLARE CM 179X179 - SX/DX
CORNER SOFA CM 179X179 - SX/DX

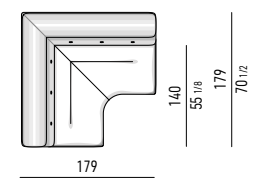

DIVANO ANGOLARE CM 240X151 - SX/DX
CORNER SOFA CM 240X151 - SX/DX

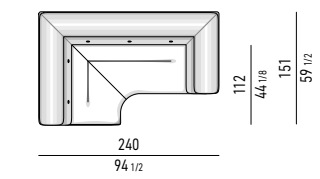

COUCH | COUCHES

COUCH CM 146X179 - 118X151
COUCH CM 146X179 - 118X151

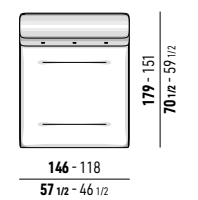

CHAISE-LONGUE | CHAISE-LONGUES

CHAISE-LONGUE CM 179X179 - 151X151 - SX/DX
CHAISE-LONGUE CM 179X179 - 151X151 - SX/DX

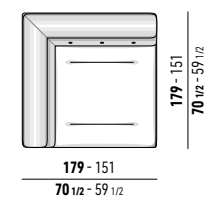

POUF | OTTOMANS

POUF CM 90X90 H39
OTTOMAN CM 90X90 H39

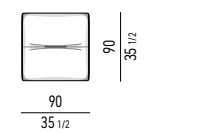

POUF CM 174X109 - 146X109 - 118X109 - 109X109 - 90X109 H39
OTTOMAN CM 174X109 - 146X109 - 118X109 - 109X109 - 90X109 H39

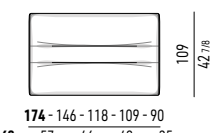

POUF CM 174X62 - 146X62 - 118X62 - 90X62 H39
OTTOMAN CM 174X62 - 146X62 - 118X62 - 90X62 H39

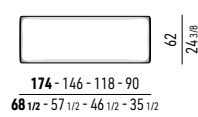

POGGIAPIEDI | FOOTSTOOLS

POGGIAPIEDI CM 174X76 - 146X76 - 118X76 - 90X76 H39
FOOTSTOOL CM 174X76 - 146X76 - 118X76 - 90X76 H39

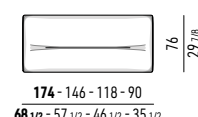

CUSCINI OPTIONAL | OPTIONAL CUSHIONS

CUSCINO SCHIENALE OPTIONAL CM 75X65
OPTIONAL BACKREST CUSHION CM 75X65

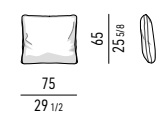

CUSCINO OPTIONAL CM 50X50
OPTIONAL CUSHION CM 50X50

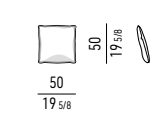

BASE
BASE

ALLUMINIO LUCIDO
POLISHED ALUMINIUM

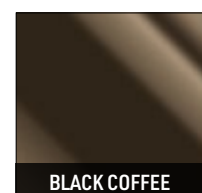
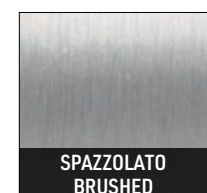

BÉZIER

MARCIO KOGAN / STUDIO MK27 DESIGN



PANORAMICA | OVERVIEW

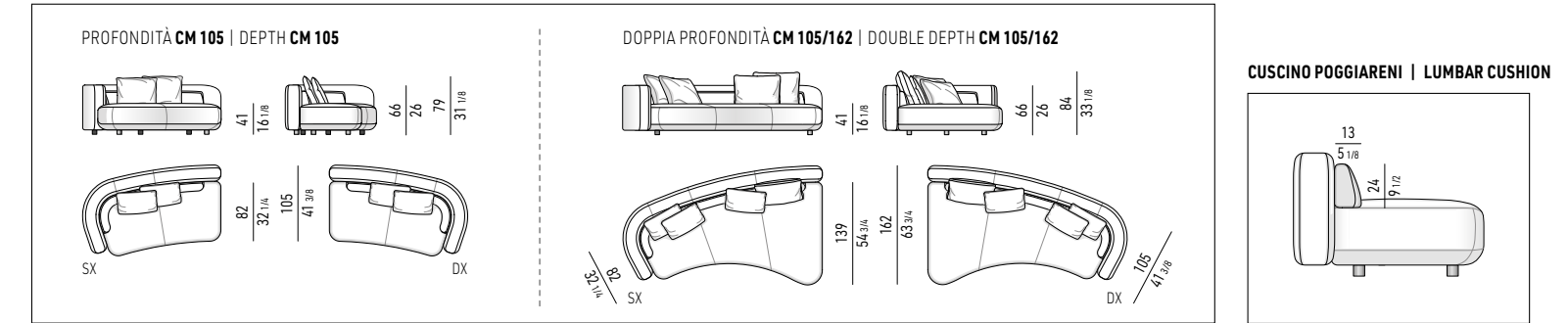

POLTRONA / PAOLINA | ARMCHAIR / PAOLINA

POLTRONA / PAOLINA CM 114X156 - SX/DX
ARMCHAIR / PAOLINA CM 114X156 - SX/DX

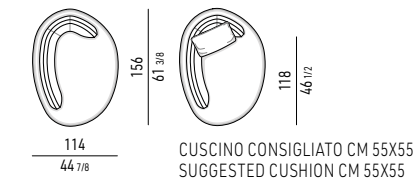

DIVANO | SOFA

DIVANO CM 297X171 - SX/DX - DOPPIA PROFONDITÀ
SOFA CM 297X171 - SX/DX - DOUBLE DEPTH

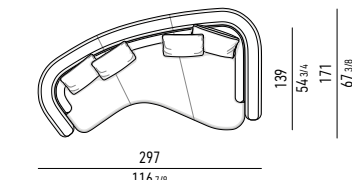

ELEMENTI TERMINALI | ELEMENTS WITH 1 ARMREST

ELEMENTO TERMINALE CM 271 - 224 - 188 - 136 - SX/DX
ELEMENT WITH 1 ARMREST CM 271 - 224 - 188 - 136 - SX/DX

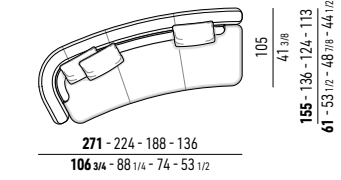

ELEMENTO TERMINALE CM 208 - SX/DX
ELEMENT WITH 1 ARMREST CM 208 - SX/DX

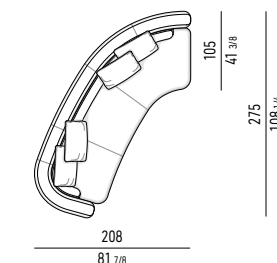

ELEMENTO TERMINALE CM 271X162 - SX/DX - DOPPIA PROFONDITÀ
ELEMENT WITH 1 ARMREST CM 271X162 - SX/DX - DOUBLE DEPTH

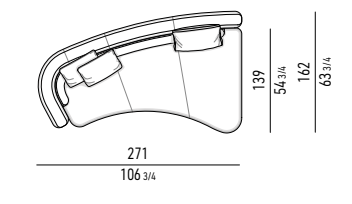

ELEMENTO TERMINALE CM 273X206 - SX/DX - DOPPIA PROFONDITÀ
ELEMENT WITH 1 ARMREST CM 273X206 - SX/DX - DOUBLE DEPTH

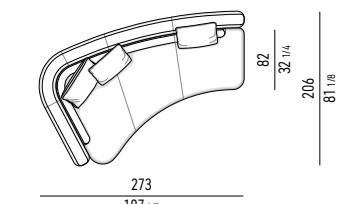

ELEMENTI CENTRALI | CENTRAL ELEMENTS

ELEMENTO CENTRALE CM 224 - 127
CENTRAL ELEMENT CM 224 - 127

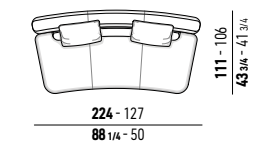

ELEMENTO CENTRALE CM 230X277 - 274X224 - 220X188 - SX/DX - DOPPIA PROFONDITÀ
CENTRAL ELEMENT CM 230X277 - 274X224 - 220X188 - SX/DX - DOUBLE DEPTH

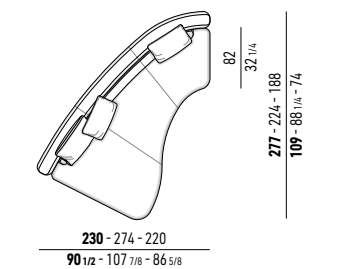

ELEMENTO ANGOLARE | CORNER ELEMENT

ELEMENTO ANGOLARE CM 208X197
CORNER ELEMENT CM 208X197

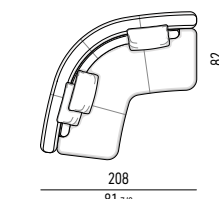

CHAISE-LONGUE | CHAISE-LONGUES

CHAISE-LONGUE CM 190X210 - 175X210 - SX/DX
CHAISE-LONGUE CM 190X210 - 175X210 - SX/DX

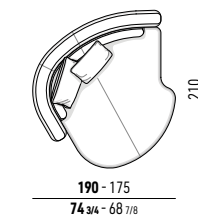

CHAISE-LONGUE CM 228X228 - SX/DX
CHAISE-LONGUE CM 228X228 - SX/DX

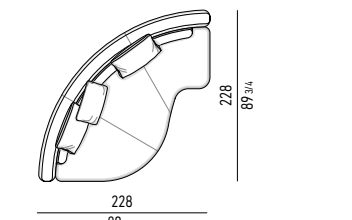

POUF | OTTOMANS

POUF CM 140X131 - 105X97 H41
OTTOMAN CM 140X131 - 105X97 H41

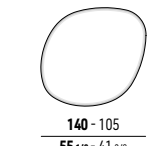

POUF CM 129X114 - 93X78 H41
OTTOMAN CM 129X114 - 93X78 H41

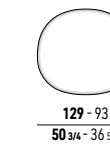

POUF CM 114X156 - 78X121 H41
OTTOMAN CM 114X156 - 78X121 H41

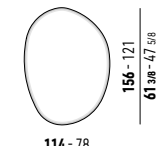

PIEDINI / BASI PAOLINA E POUF
FEET / PAOLINA AND OTTOMAN BASES

METALLO OPACO
MATT METAL

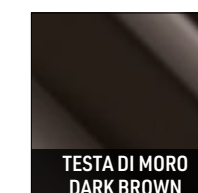

CUSCINI OPTIONAL | OPTIONAL CUSHIONS

CUSCINO SCHIENALE OPTIONAL CM 65X60
OPTIONAL BACKREST CUSHION CM 65X60

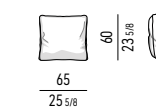

CUSCINO OPTIONAL CM 55X55
OPTIONAL CUSHION CM 55X55

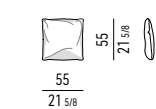



PANORAMICA | OVERVIEW

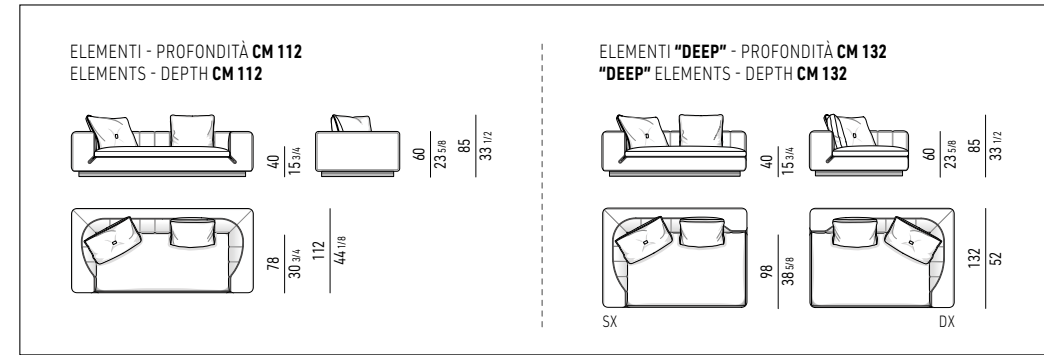

POUF | OTTOMAN

VERSIONE CON RUOTE | VERSION WITH CASTORS

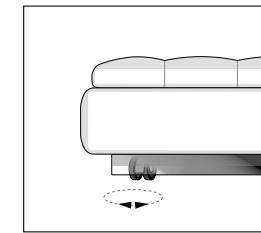

APPOGGIO A TERRA TRAMITE RUOTE CON MOVIMENTO GIREVOLE A 360°
RESTS ON CASTORS WITH 360° SWIVEL

DIVANI | SOFAS

DIVANO CM **302** - 282 - 262 - 242
SOFA CM **302** - 282 - 262 - 242

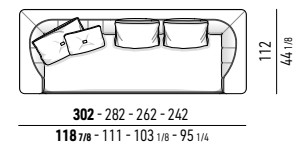

ELEMENTI CENTRALI | CENTRAL ELEMENTS

ELEMENTO CENTRALE CM **244** - 224 - 204 - 184 - 164 - 144 - 124 - 104
CENTRAL ELEMENT CM **244** - 224 - 204 - 184 - 164 - 144 - 124 - 104

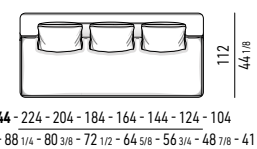

ELEMENTI TERMINALI | ELEMENTS WITH 1 ARMREST

PROFONDITÀ CM 112 | DEPTH CM 112

ELEMENTO ANGOLARE TERMINALE CM **112X112** - SX/DX
CORNER ELEMENT WITH ARMREST CM **112X112** - SX/DX

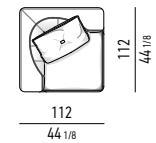

ELEMENTO TERMINALE CM **272** - 252 - 232 - 212 - 192 - 172 - 152 - 132 - SX/DX
ELEMENT WITH ARMREST CM **272** - 252 - 232 - 212 - 192 - 172 - 152 - 132 - SX/DX

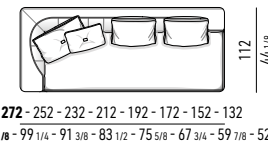

ELEMENTI TERMINALI "DEEP" | "DEEP" ELEMENTS WITH 1 ARMREST

PROFONDITÀ CM 132 | DEPTH CM 132

DEEP ELEMENTO ANGOLARE TERMINALE CM **132X132** - SX/DX
DEEP CORNER ELEMENT WITH ARMREST CM **132X132** - SX/DX

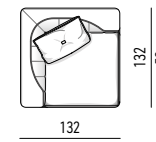

DEEP ELEMENTO TERMINALE CM **212X132** - 192X132 - 172X132 - SX/DX
DEEP ELEMENT WITH ARMREST CM **212X132** - 192X132 - 172X132 - SX/DX

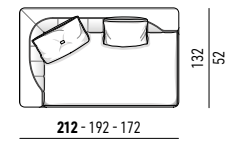

ELEMENTI ANGOLARI | CORNER ELEMENTS

ELEMENTO ANGOLARE CM **172X152** - 152X152 - SX/DX
CORNER ELEMENT CM **172X152** - 152X152 - SX/DX

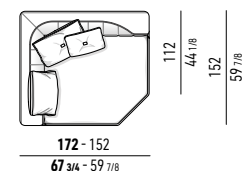

COUCH | COUCHES

COUCH CM **144X172** - 124X152 - 104X132
COUCH CM **144X172** - 124X152 - 104X132

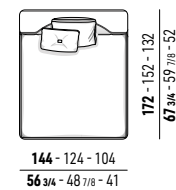

BASE
BASE

METALLO LUCIDO
POLISHED METAL

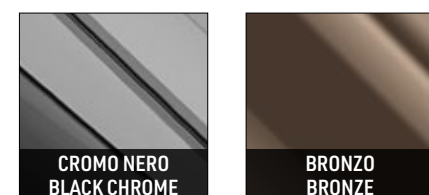

CHAISE-LONGUE | CHAISE-LONGUES

CHAISE-LONGUE CM **172X172** - 152X152 - SX/DX
CHAISE-LONGUE CM **172X172** - 152X152 - SX/DX

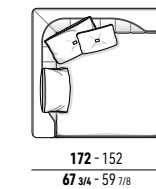

CHAISE-LONGUE CM **132X212** - 132X192 - 132X172 - SX/DX
CHAISE-LONGUE CM **132X212** - 132X192 - 132X172 - SX/DX

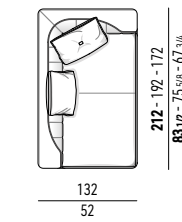

POUF | OTTOMANS

VERSIONE FISSA | FIXED VERSION

POUF CM **84X84 H36**
OTTOMAN CM **84X84 H36**

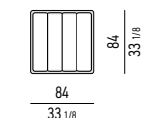

VERSIONE FISSA | FIXED VERSION

POUF CM **112X112** - 84X112 H36
OTTOMAN CM **112X112** - 84X112 H36

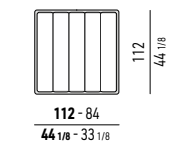

VERSIONE FISSA O VERSIONE CON RUOTE | FIXED VERSION OR VERSION WITH CASTORS

POUF CM **184X64** - 164X64 - 144X64 - 124X64 - 104X64 H36
OTTOMAN CM **184X64** - 164X64 - 144X64 - 124X64 - 104X64 H36

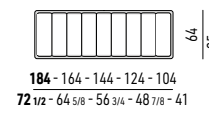

CUSCINI OPTIONAL | OPTIONAL CUSHIONS

CUSCINO SCHIENALE OPTIONAL CM **75X65**
OPTIONAL BACKREST CUSHION CM **75X65**

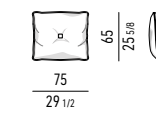

CUSCINO SCHIENALE OPTIONAL CM **65X55**
OPTIONAL BACKREST CUSHION CM **65X55**

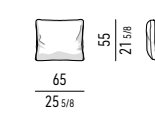

CUSCINO SCHIENALE OPTIONAL CM **55X55**
OPTIONAL BACKREST CUSHION CM **55X55**

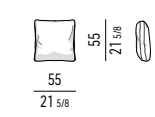

CUSCINO OPTIONAL CM **50X50**
OPTIONAL CUSHION CM **50X50**

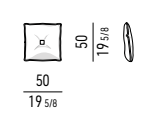

CUSCINO SCHIENALE OPTIONAL **RELAX** CM **75X65**
RELAX OPTIONAL BACKREST CUSHION CM **75X65**

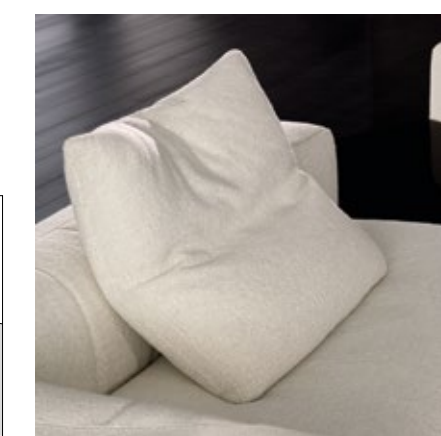
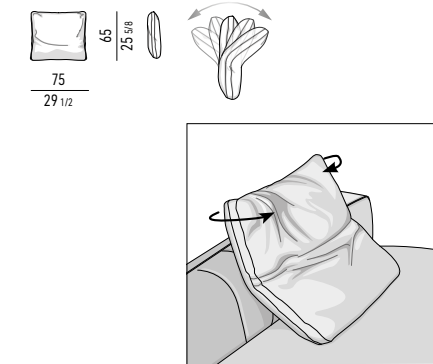

CUSCINO SCHIENALE OPTIONAL "RELAX"

IL CUSCINO ADDIZIONALE "RELAX" FUNGE DA POGGIA TESTA, GRAZIE AD UNA STRUTTURA IN ALLUMINIO MULTIDIREZIONALE INTERNA MODELLABILE A PIACIMENTO, COMPLETAMENTE AVVOLTA DA UNA STRATIFICAZIONE SOFISTICATA DI POLIURETANI, CAPACE DI CONFERIRE IL MASSIMO COMFORT.

"RELAX" OPTIONAL BACKREST CUSHION

THE ADDITIONAL "RELAX" CUSHION SERVE AS HEADREST, THANKS TO AN INTERNAL, MULTIDIRECTIONAL ALUMINIUM FRAME THAT CAN BE SHAPED AS DESIRED, FULLY ENVELOPED IN A SOPHISTICATED LAYERING OF POLYURETHANES, OFFERING MAXIMUM COMFORT.

PIPING

PELLE
LEATHER



PELLE
LEATHER

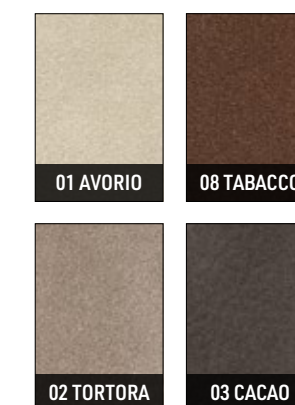

STAGE

HANNES PEER DESIGN

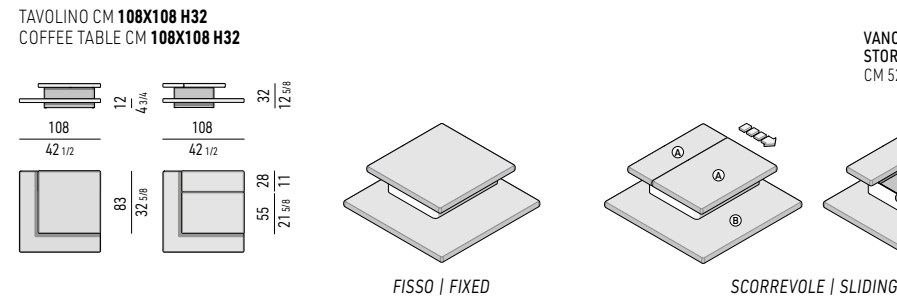
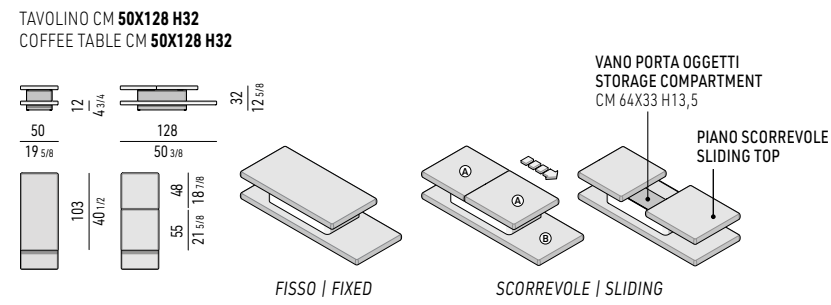
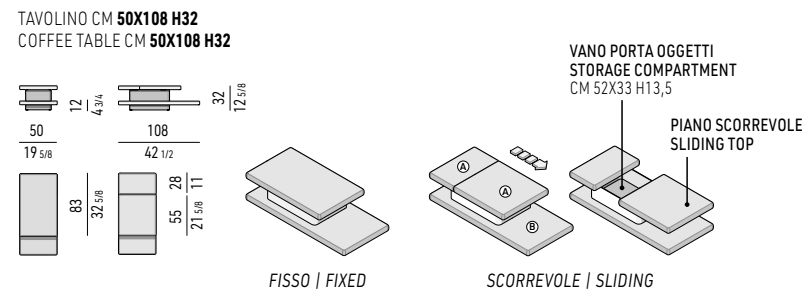

ESEMPI DI CONFIGURAZIONE | CONFIGURATION EXAMPLES

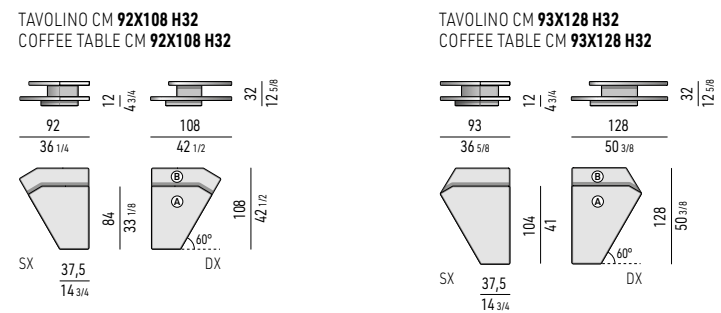
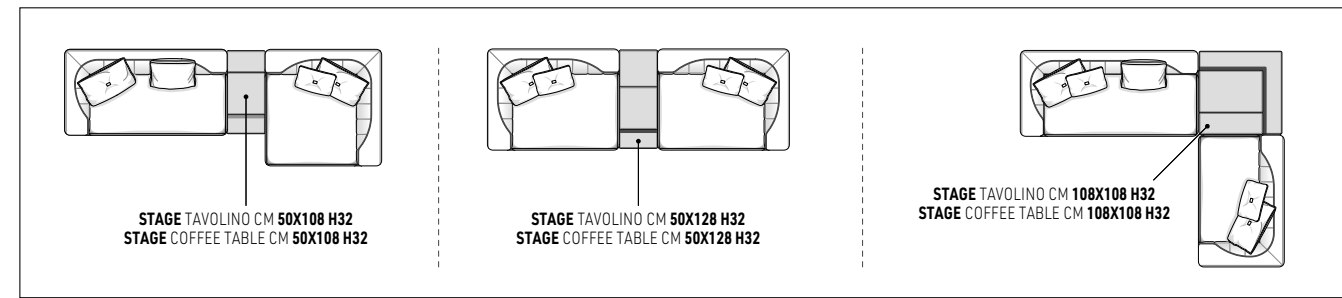

ESEMPI DI CONFIGURAZIONE | CONFIGURATION EXAMPLES

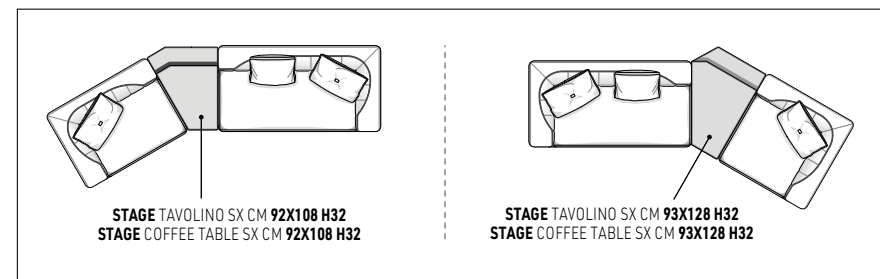

ABBINAMENTI FINITURE | FINISHES COMBINATIONS

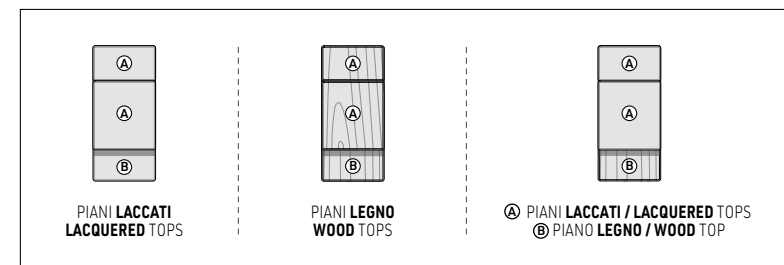

PIANI TOPS



BASE E VANO PORTA OGGETTI BASE AND STORAGE COMPARTMENT

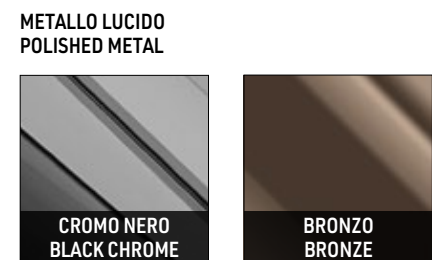

FONDO VANO PORTA OGGETTI STORAGE COMPARTMENT BOTTOM



VIVIENNE

GAMFRATESI DESIGN



PANORAMICA | OVERVIEW

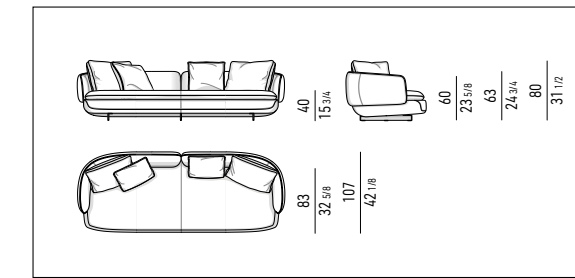

PIANI | TOPS

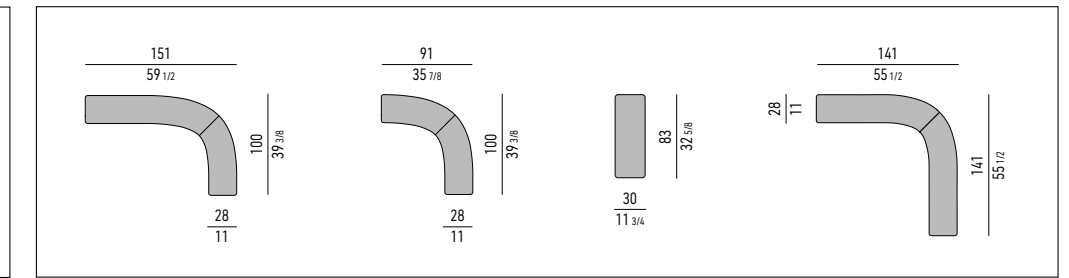

DIVANI | SOFAS

DIVANO LOUNGE CM 212
LOUNGE SOFA CM 212

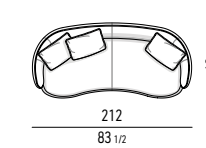

DIVANO CM 276
SOFA CM 276

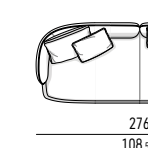

DIVANO CM 290 - SCHIENALE 185 - 125 CON TOP - SX/DX
SOFA CM 290 - BACKREST 185 - 125 WITH TOP - SX/DX

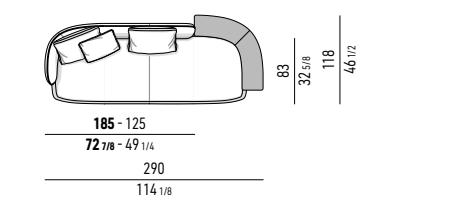

ELEMENTI TERMINALI | ELEMENTS WITH 1 ARMREST

ELEMENTO TERMINALE CM 245 - 200 - 158 - 140 - SX/DX
ELEMENT WITH 1 ARMREST CM 245 - 200 - 158 - 140 - SX/DX

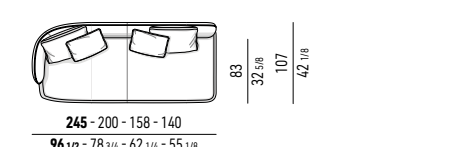

ELEMENTO TERMINALE CON TOP CM 245 - 200 - SX/DX
ELEMENT WITH 1 ARMREST WITH TOP CM 245 - 200 - SX/DX

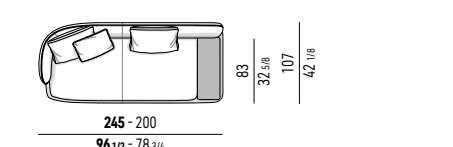

ELEMENTO TERMINALE INCLINATO CM 242X154 - SX/DX
INCLINED ELEMENT WITH 1 ARMREST CM 242X154 - SX/DX

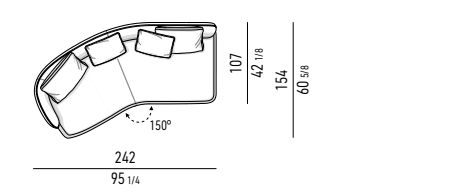

CHAISE-LONGUE | CHIASE-LONGUES

ELEMENTO TERMINALE INCLINATO CON TOP CM 242X154 - SX/DX
INCLINED ELEMENT WITH ARMREST WITH TOP CM 242X154 - SX/DX

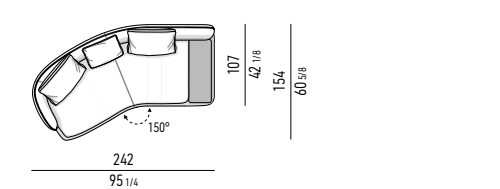

CHAISE-LONGUE ANGOLARE CM 132X132 - SX/DX
CORNER CHAISE-LONGUE CM 132X132 - SX/DX

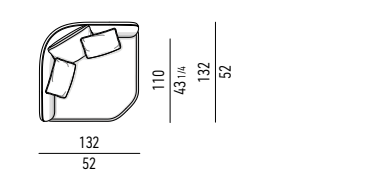

CHAISE-LONGUE CM 158X163 - SX/DX
CHAISE-LONGUE CM 158X163 - SX/DX

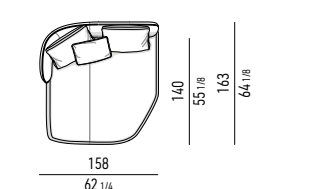

POUF | OTTOMANS

POUF CON TOP CM 154X118 H40 - SX/DX
OTTOMAN WITH TOP CM 154X118 H40 - SX/DX

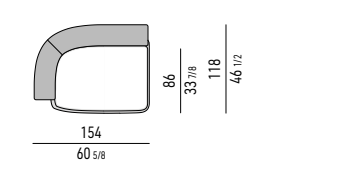

POUF CON TOP CM 143X143 H40 - SX/DX
OTTOMAN WITH TOP CM 143X143 H40 - SX/DX

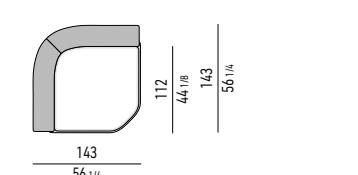

POUF CM 125X71 H40
OTTOMAN CM 125X71 H40

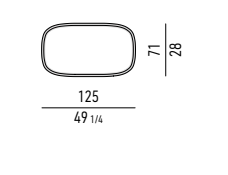

CUSCINI OPTIONAL | OPTIONAL CUSHIONS

CUSCINO SCHIENALE OPTIONAL CM 65X60
OPTIONAL BACKREST CUSHION CM 65X60

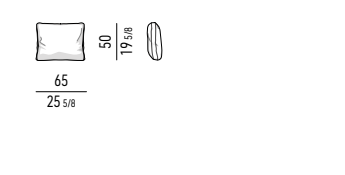

CUSCINO OPTIONAL CM 50X50
OPTIONAL CUSHION CM 50X50

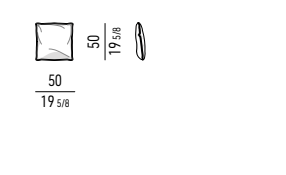

PIANI D'APPOGGIO TABLE-TOPS

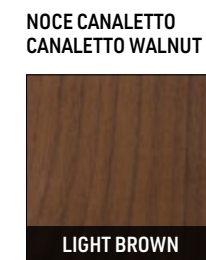
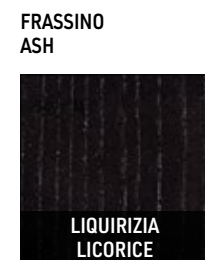
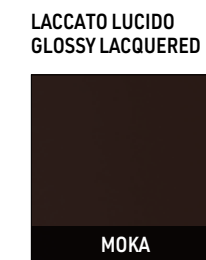

BASI BASES

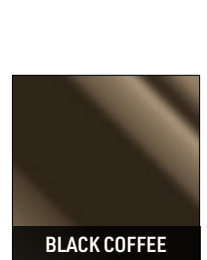



PANORAMICA | OVERVIEW

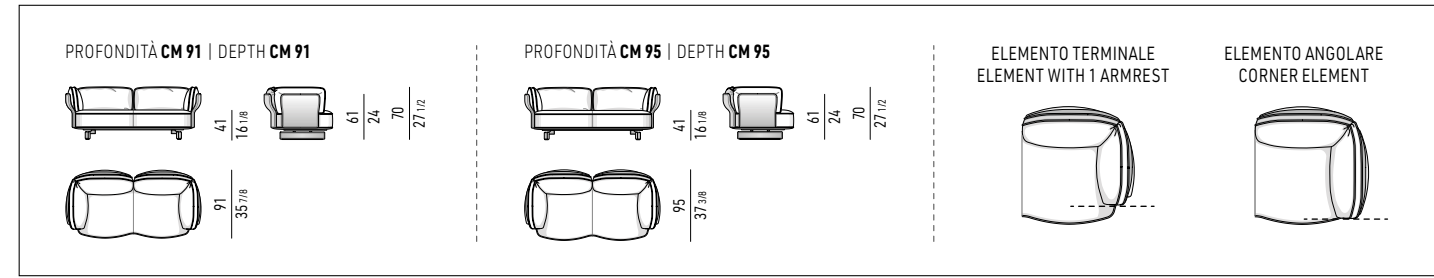

PROFONDITÀ CM 91 | DEPTH CM 91

POLTRONE | ARMCHAIRS

POLTRONA CM 104X91 H69
ARMCHAIR CM 104X91 H69

FISSA | FIXED

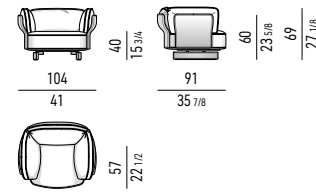

POLTRONA CON BASE CM 104X92 H70
ARMCHAIR WITH BASE CM 104X92 H70

FISSA O GIREVOLE | FIXED OR SWIVEL

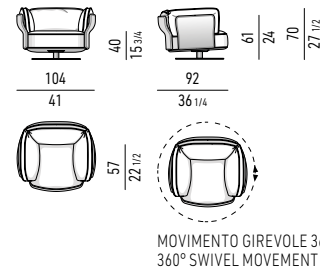

POLTRONA CON BRACCIOLO CM 92X91 H69 - SX/DX
ARMCHAIR WITH ARMREST CM 92X91 H69 - SX/DX

FISSA | FIXED

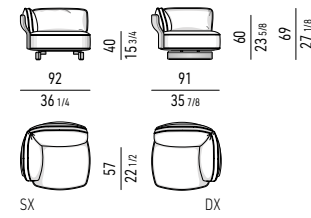

POLTRONA CON BRACCIOLO CON BASE CM 92X92 H70 - SX/DX
ARMCHAIR WITH ARMREST WITH BASE CM 92X92 H70 - SX/DX

FISSA O GIREVOLE | FIXED OR SWIVEL

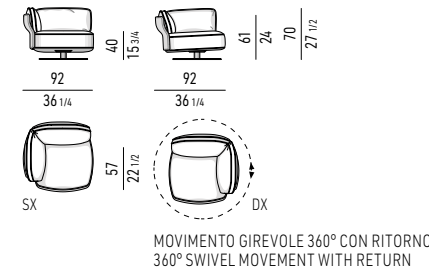

POLTRONA SENZA BRACCIOLO CM 80X91 H69
ARMCHAIR WITHOUT ARMRESTS CM 80X91 H69

FISSA | FIXED

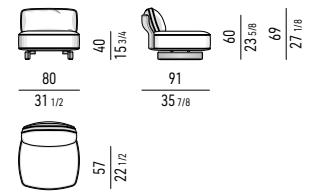

POLTRONA SENZA BRACCIOLO CON BASE CM 80X92 H66
ARMCHAIR WITHOUT ARMRESTS WITH BASE CM 80X92 H66

FISSA O GIREVOLE | FIXED OR SWIVEL

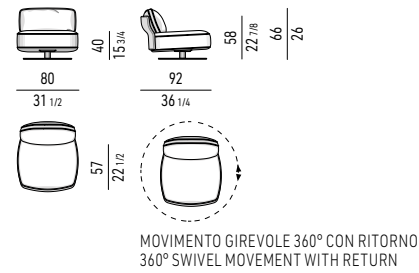

POGGIAPIEDI / POUF CM 80X78 H40
FOOTSTOOL / OTTOMAN CM 80X78 H40

FISSO | FIXED

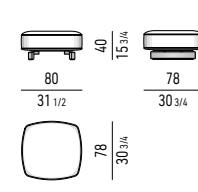

POGGIAPIEDI / POUF CON BASE CM 80X78 H42
FOOTSTOOL / OTTOMAN WITH BASE CM 80X78 H42

FISSO | FIXED

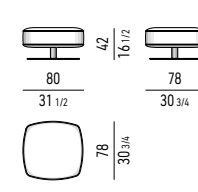

DIVANI | SOFAS

DIVANO CM 254X91 - 180X91
SOFA CM 254X91 - 180X91

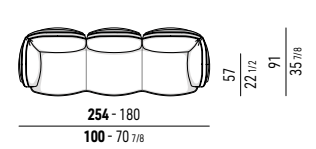

ELEMENTI CENTRALI | CENTRAL ELEMENTS

ELEMENTO CENTRALE CM 230X91 - 156X91
CENTRAL ELEMENT CM 230X91 - 156X91

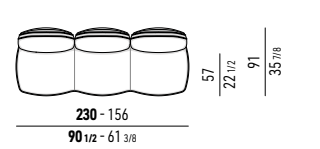

PIEDI / BASE
FEET / BASE

ALLUMINIO LUCIDO
POLISHED ALUMINIUM

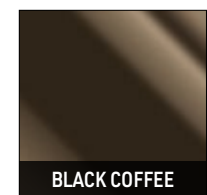

BASE POLTRONA / POGGIAPIEDI
ARMCHAIR / FOOTSTOOL BASE

METALLO LUCIDO
POLISHED METAL

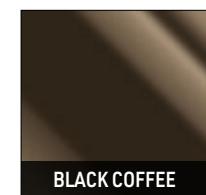

PANNELLI DI SOSTEGNO
SUPPORT PANELS

LACCATO LUCIDO
GLOSSY LACQUERED

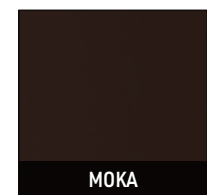

CAPPUCCINO



ARMY GREEN

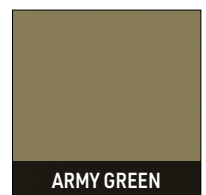

PELLE
LEATHER



TESSUTO
FABRIC



PROFONDITÀ CM 95 | DEPTH CM 95

DIVANI | SOFAS

DIVANO CM 330X95 - 254X95 - 180X95
SOFA CM 330X95 - 254X95 - 180X95

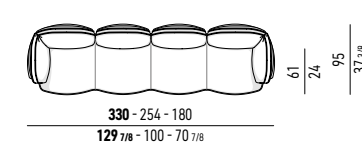

DIVANO ANGOLARE CM 330X95 - 254X95 - 180X95 - SX/DX
CORNER SOFA CM 330X95 - 254X95 - 180X95 - SX/DX

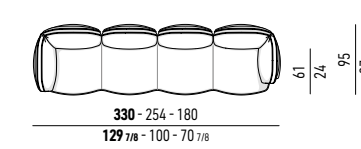

ELEMENTI TERMINALI | ELEMENTS WITH 1 ARMREST

ELEMENTO TERMINALE CM 316X95 - 242X95 - 168X95 - SX/DX
ELEMENT WITH 1 ARMREST CM 316X95 - 242X95 - 168X95 - SX/DX

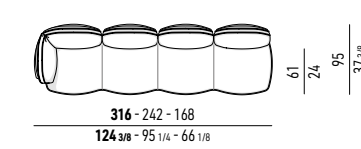

ELEMENTI ANGOLARI | CORNER ELEMENTS

ELEMENTO ANGOLARE CM 316X95 - 242X95 - 168X95 - SX/DX
CORNER ELEMENT CM 316X95 - 242X95 - 168X95 - SX/DX

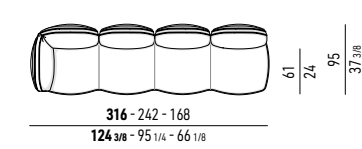

ELEMENTI CENTRALI | CENTRAL ELEMENTS

ELEMENTO CENTRALE CM 304X95 - 230X95 - 156X95
CENTRAL ELEMENT CM 304X95 - 230X95 - 156X95

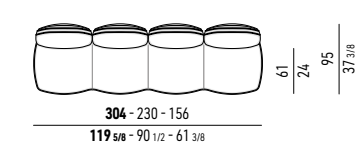

ELEMENTI ISOLA | ISLAND ELEMENTS

ISOLA CM 168X168 - SX/DX - MOD. A
ISLAND CM 168X168 - SX/DX - MOD. A

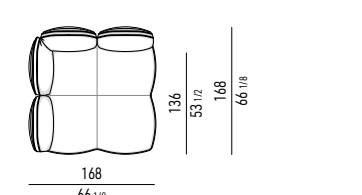

ISOLA CM 168X168 - SX/DX - MOD. B
ISLAND CM 168X168 - SX/DX - MOD. B

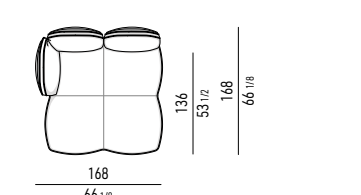

ISOLA CM 156X168 - SX/DX - MOD. C
ISLAND CM 156X168 - SX/DX - MOD. C

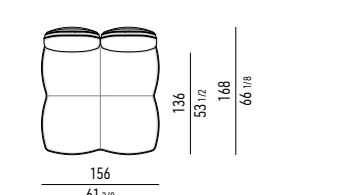

ISOLA CM 168X168 - SX/DX - MOD. D
ISLAND CM 168X168 - SX/DX - MOD. D

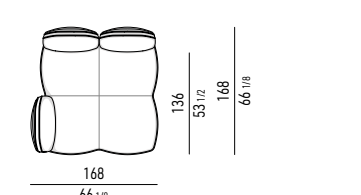

ISOLA CM 168X168 - SX/DX - MOD. E
ISLAND CM 168X168 - SX/DX - MOD. E

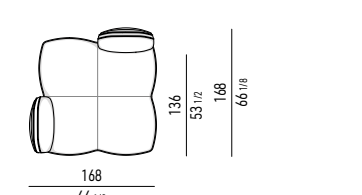

ISOLA CM 156X168 - SX/DX - MOD. F
ISLAND CM 156X168 - SX/DX - MOD. F

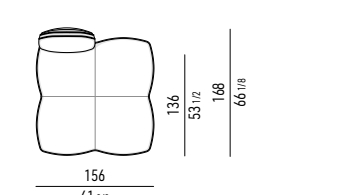

ISOLA CM 156X156 H41 - SX/DX - MOD. G
ISLAND CM 156X156 H41 - SX/DX - MOD. G

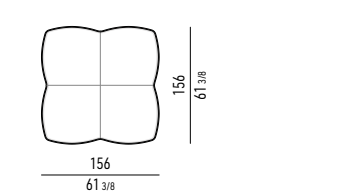

POSIZIONE BASI ELEMENTI "ISOLA" | "ISLAND" ELEMENTS BASES POSITION

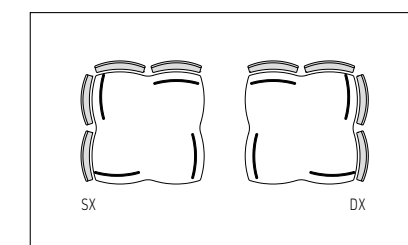

PANCA | BENCH

PANCA CM 304X82 - 230X82 - 156X82 H41
BENCH CM 304X82 - 230X82 - 156X82 H41

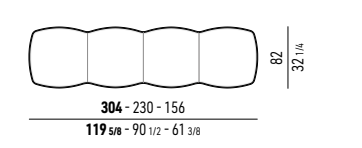

CUSCINO OPTIONAL | OPTIONAL CUSHION

CUSCINO OPTIONAL CM 50X50
OPTIONAL CUSHION CM 50X50

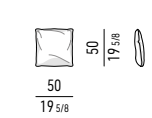

LIBRA

GIAMPIERO TAGLIAFERRI DESIGN



BERGÈRE CM 78
BERGÈRE CM 78

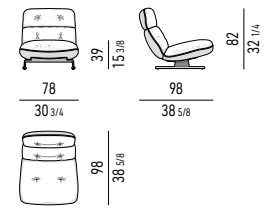

POLTRONA CM 76
ARMCHAIR CM 76

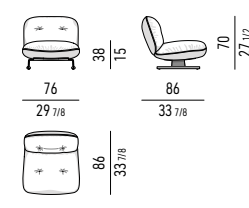

POGGIAPIEDI CM 78
FOOTSTOOL CM 78

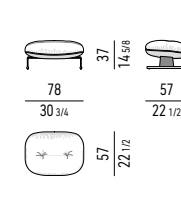

POLTRONCINA DINING CM 55
DINING LITTLE ARMCHAIR CM 55

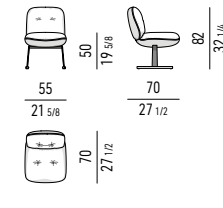

PANCA CM 212X52 - 205X52 - 192X52 - 172X52 - 165X52 - 152X52 H37
BENCH CM 212X52 - 205X52 - 192X52 - 172X52 - 165X52 - 152X52 H37

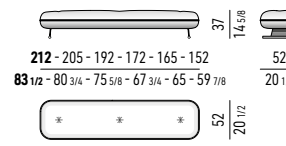

PANCA CM 192X92 H37
BENCH CM 192X92 H37

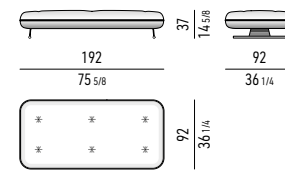

PANCA CM 192X92 H45 CON CUSCINO AMOVIBILE
BENCH CM 192X92 H45 WITH REMOVABLE CUSHION

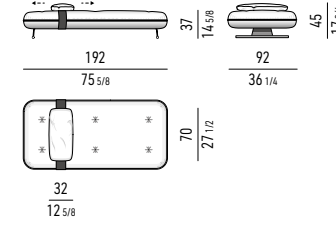

PANCA CM 192X152 H37
BENCH CM 192X152 H37

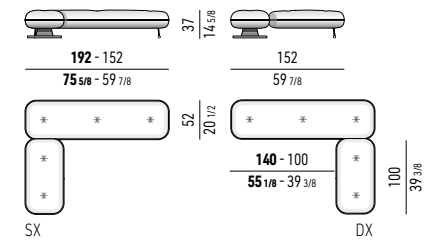

LAUREL

GIAMPIERO TAGLIAFERRI DESIGN



POLTRONA CM 96
ARMCHAIR CM 96

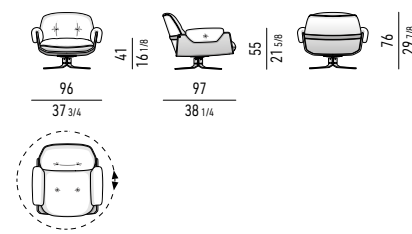

POGGIAPIEDI CM 76
FOOTSTOOL CM 76

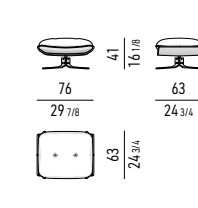

POLTRONCINA DINING CM 63
DINING LITTLE ARMCHAIR CM 63

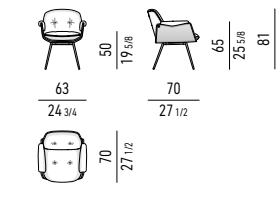

MOVIMENTO GIREVOLE 360° CON RITORNO
360° SWIVEL MOVEMENT WITH RETURN



SCocca SHELL

NOCE CANALETTO
CANALETTO WALNUT

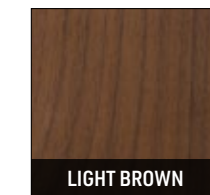

LIGHT BROWN

PALISSANDRO SANTOS
PALISANDER SANTOS

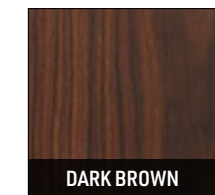

DARK BROWN

FRASSINO
ASH



LIQUIRIZIA
LICORICE

PELLE
LEATHER



DISPONIBILE IN PELLE ASPEN, BIG SUR O CARMEL
AVAILABLE IN ASPEN, BIG SUR OR CARMEL LEATHER

BASE BASE

METALLO OPACO
MATT METAL

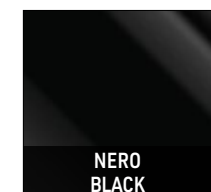

NERO
BLACK

BARRE CILINDRICHE CYLINDRICAL BARS

METALLO LUCIDO
POLISHED METAL



CROMO
CHROME

BASE E BARRE CILINDRICHE BASE AND CYLINDRICAL BARS

METALLO LUCIDO
POLISHED METAL

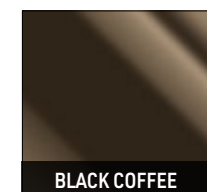

BLACK COFFEE

POLTRONA / POGGIAPIEDI | ARMCHAIR / FOOTSTOOL

BASE E VITE DECORATIVA BASE AND DECORATIVE SCREW

METALLO LUCIDO
POLISHED METAL

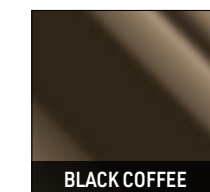

BLACK COFFEE

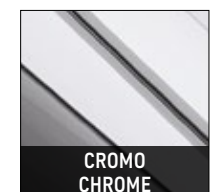

CROMO
CHROME

POLTRONCINA DINING | DINING LITTLE ARMCHAIR

BASE E VITE DECORATIVA BASE AND DECORATIVE SCREW

METALLO LUCIDO
POLISHED METAL

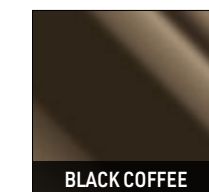

BLACK COFFEE

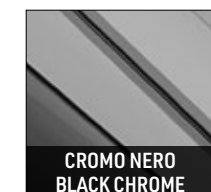

CROMO NERO
BLACK CHROME

SENDAI DINING (UPDATE) INODA+SVEJE DESIGN

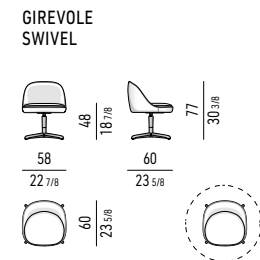
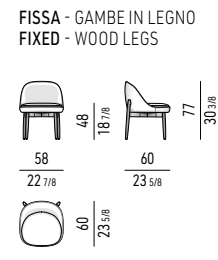
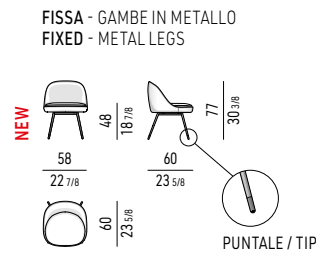

MOVIMENTO GIREVOLE 360° CON RITORNO
360° SWIVEL MOVEMENT WITH RETURN

VERSIONE GIREVOLE | SWIVEL VERSION

BASE
BASE

METALLO LUCIDO
POLISHED METAL

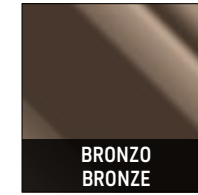

RAZZE
SPOKES

FRASSINO
ASH



NOCE CANALETTO
CANALETTO WALNUT

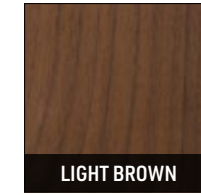

VERSIONE FISSA | FIXED VERSION

GAMBE
LEGS

FRASSINO
ASH



NOCE CANALETTO
CANALETTO WALNUT

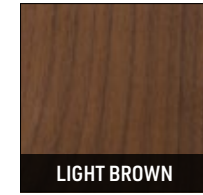

METALLO LUCIDO
POLISHED METAL

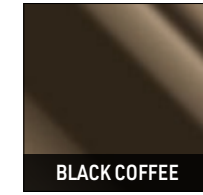

NEW 2025 FINISH

PUNTALI *
TIPS *

ALLUMINIO LUCIDO
POLISHED ALUMINIUM



* DISPONIBILI SOLO CON LE GAMBE IN METALLO
AVAILABLE ONLY WITH METAL LEGS

TAPE DINING (UPDATE) NENDO DESIGN

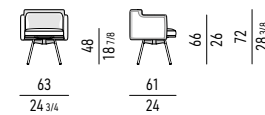

MOVIMENTO GIREVOLE 360° CON RITORNO
360° SWIVEL MOVEMENT WITH RETURN

BASE
BASE

METALLO LUCIDO
POLISHED METAL

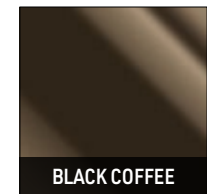

TRIO DINING (UPDATE) MARCIO KOGAN / STUDIO MK27 DESIGN



POLTRONA | ARMCHAIR

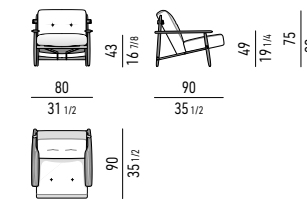

POLTRONCINA DINING | DINING LITTLE ARMCHAIR

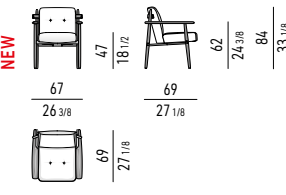

VERSIONE | VERSION "MIX"

MIX "A"

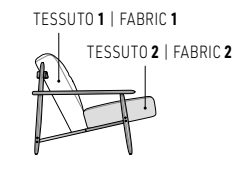

MIX "B"

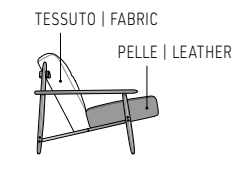

MIX "C"

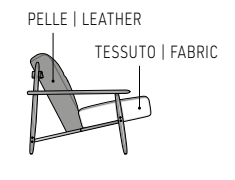

VERSIONE | VERSION "MIX"

MIX "A"

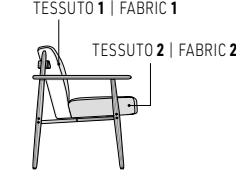

MIX "B"

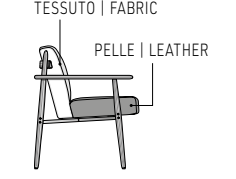

MIX "C"

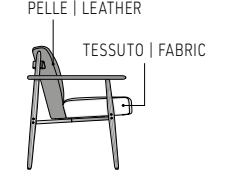

TELAIO E VITI DECORATIVE FRAME AND DECORATIVE SCREWS

METALLO LUCIDO
POLISHED METAL

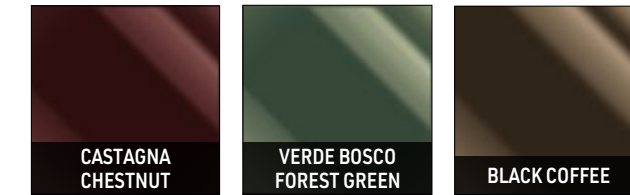

POLTRONA | ARMCHAIR

STRUTTURA
STRUCTURE

NOCE CANALETTO
CANALETTO WALNUT

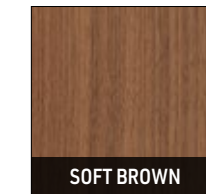

FRASSINO
ASH



POLTRONCINA DINING | DINING LITTLE ARMCHAIR

STRUTTURA
STRUCTURE

FRASSINO
ASH



NOCE CANALETTO
CANALETTO WALNUT

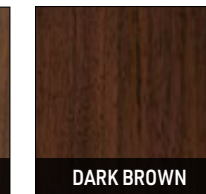
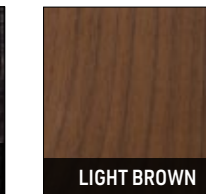

NEW 2025 FINISH

YOKO DINING (UPDATE) INODA+SVEJE DESIGN



POLTRONA | ARMCHAIR

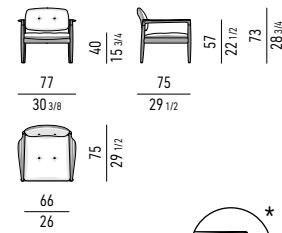

PANCA / POGGIAPIEDI | BENCH / FOOTSTOOL

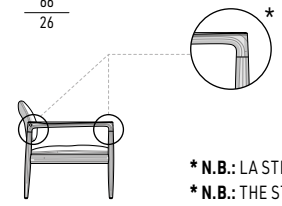
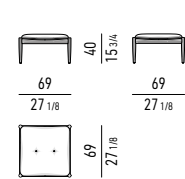

* N.B.: LA STRUTTURA PRESENTA UN SEGNO DI GIUNZIONE IN PROSSIMITÀ DELL'UNIONE DELLA GAMBA CON IL BRACCIOLO, SIA NELLA PARTE ANTERIORE CHE POSTERIORE.
 * N.B.: THE STRUCTURE SHOWS A JUNCTURE MARK NEAR THE POINT WHERE THE LEG MEETS THE ARMREST, ON BOTH THE FRONT AND BACK PARTS.

POLTRONCINA DINING | DINING LITTLE ARMCHAIR

CON BRACCIOLI | WITH ARMRESTS

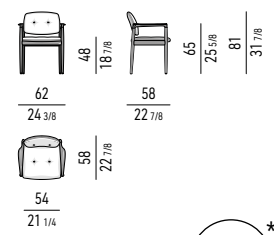

SENZA BRACCIOLI | WITHOUT ARMRESTS

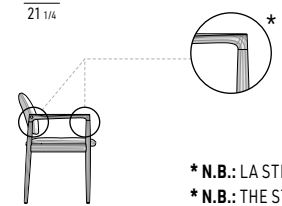
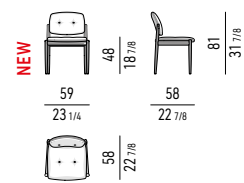

* N.B.: LA STRUTTURA PRESENTA UN SEGNO DI GIUNZIONE IN PROSSIMITÀ DELL'UNIONE DELLA GAMBA CON IL BRACCIOLO, SIA NELLA PARTE ANTERIORE CHE POSTERIORE.
 * N.B.: THE STRUCTURE SHOWS A JUNCTURE MARK NEAR THE POINT WHERE THE LEG MEETS THE ARMREST, ON BOTH THE FRONT AND BACK PARTS.

POLTRONA | ARMCHAIR

STRUTTURA STRUCTURE

FRASSINO
ASH



NOCE CANALETTO
CANALETTO WALNUT

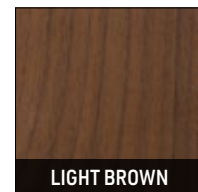

VITE DECORATIVA DECORATIVE SCREW

ACCIAIO INOX
STAINLESS STEEL

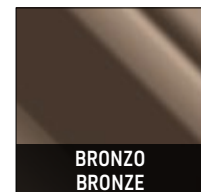

POLTRONCINA DINING | DINING LITTLE ARMCHAIR

STRUTTURA STRUCTURE

FRASSINO
ASH



NOCE CANALETTO
CANALETTO WALNUT



LACCATO OPACO
MATT LACQUERED

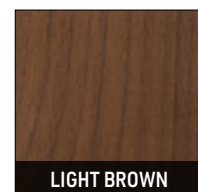

CASTAGNA
CHESTNUT



MUSCHIO
MOSS

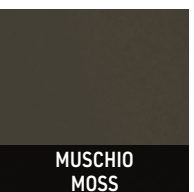

SAND



FANGO
MUD



ANDRÉE

HANNES PEER DESIGN



TAVOLINI ESAGONALI | HEXAGONAL COFFEE TABLES

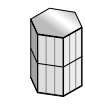
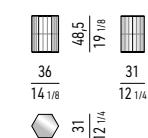

VERSIONE CERAMICA
CERAMIC VERSION

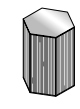

VERSIONE FRASSINO
ASH VERSION

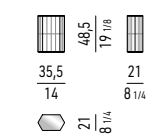

VERSIONE CERAMICA
CERAMIC VERSION

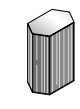

VERSIONE FRASSINO
ASH VERSION

TAVOLINI QUADRATI E RETTANGOLARI | SQUARED AND RECTANGULAR COFFEE TABLES

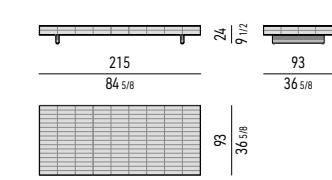
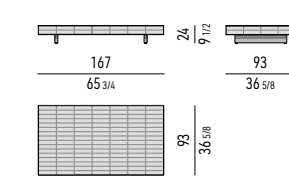
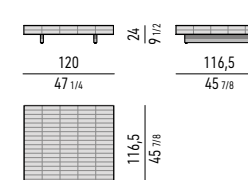
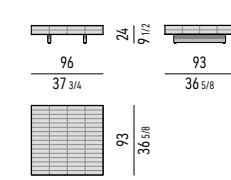

TAVOLINI ESAGONALI | HEXAGONAL COFFEE TABLES

RIVESTIMENTO STRUTTURA STRUCTURE COVER

CERAMICA SMALTATA
GLAZED CERAMIC

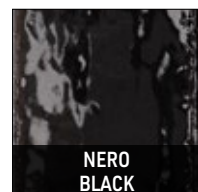

FRASSINO
ASH



PIASTRE PLATES

OTTONE
BRASS

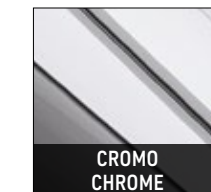

SPIGOLI CORNERS

ALLUMINIO LUCIDO
POLISHED ALUMINIUM



TAVOLINI QUADRATI E RETTANGOLARI | SQUARED AND RECTANGULAR COFFEE TABLES

RIVESTIMENTO STRUTTURA STRUCTURE COVER

CERAMICA SMALTATA
GLAZED CERAMIC

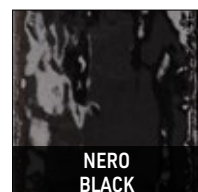
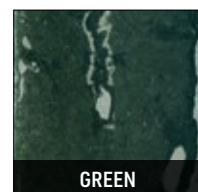

SPIGOLI CORNERS

ALLUMINIO LUCIDO
POLISHED ALUMINIUM



GAMBE LEGS

NOCE CANALETTO
CANALETTO WALNUT

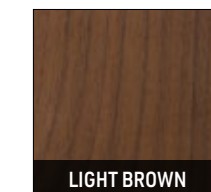

LIBRA COFFEE TABLE

GIAMPIERO TAGLIAFERRI DESIGN

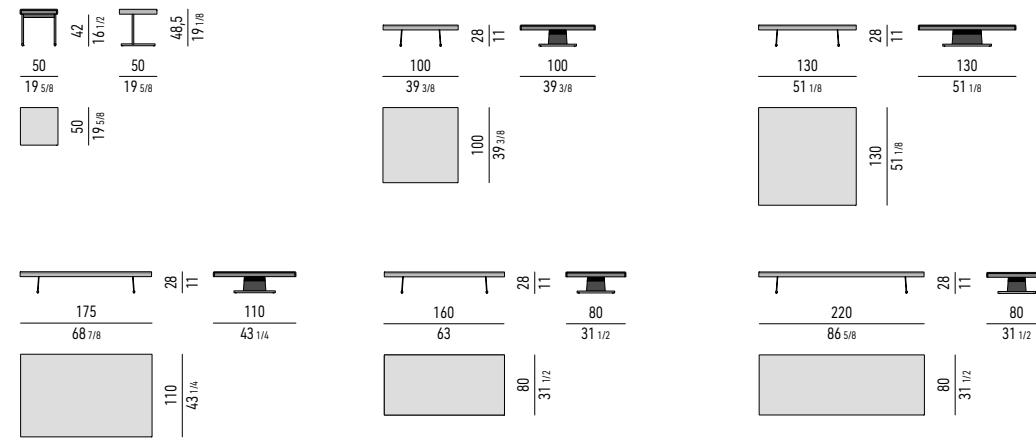

GAMBE LEGS

METALLO OPACO
MATT METAL

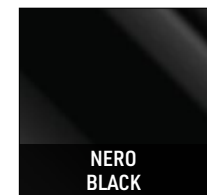

BARRE CILINDRICHE E FASCE LATERALI CYLINDRICAL BARS AND SIDE STRIPS

METALLO LUCIDO
POLISHED METAL



PIANO TOP

PIETRA
STONE



MARMO
MARBLE



MARMO
MARBLE

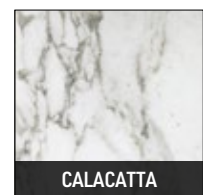

GIALLO SIENA



GRANITO
GRANITE

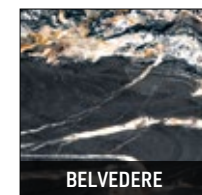

NOCE CANALETTO
CANALETTO WALNUT

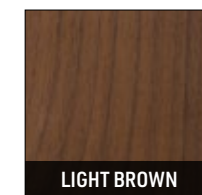

FRASSINO
ASH



BÉZIER COFFEE TABLE

MARCIO KOGAN / STUDIO MK27 DESIGN



TAVOLINO CM 105X80 H24
COFFEE TABLE CM 105X80 H24

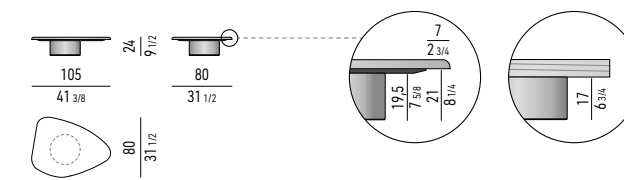

TAVOLINO CM 151,5X97 H20
COFFEE TABLE CM 151,5X97 H20

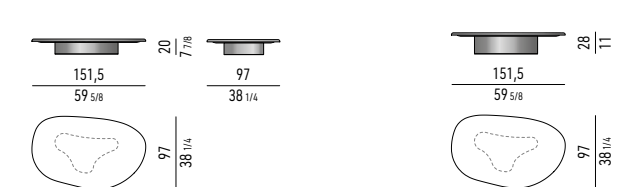

TAVOLINO CM 151,5X97 H28
COFFEE TABLE CM 151,5X97 H28

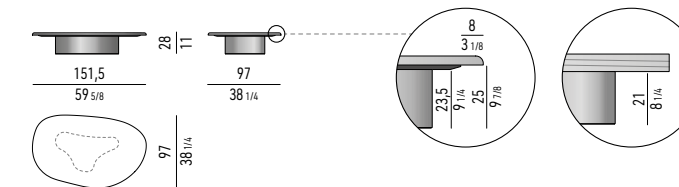

TAVOLINO CM 143X138 H20
COFFEE TABLE CM 143X138 H20

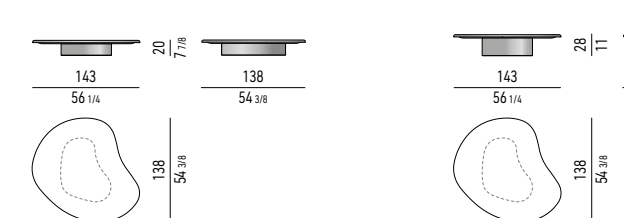

TAVOLINO CM 143X138 H28
COFFEE TABLE CM 143X138 H28

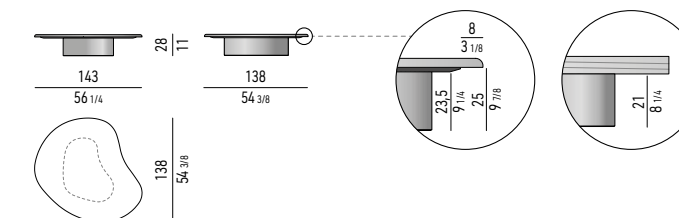

TAVOLINO CM 172,5X131 H20
COFFEE TABLE CM 172,5X131 H20

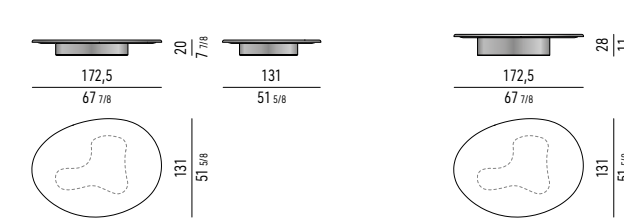

TAVOLINO CM 172,5X131 H28
COFFEE TABLE CM 172,5X131 H28

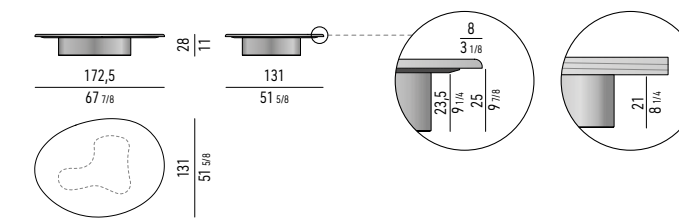

TAVOLINO CM 206X101 H20
COFFEE TABLE CM 206X101 H20

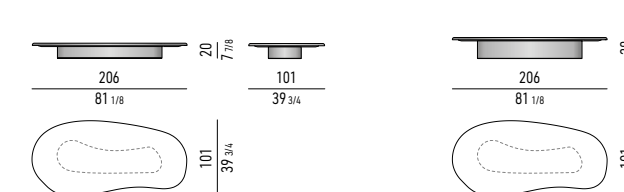

TAVOLINO CM 206X101 H28
COFFEE TABLE CM 206X101 H28

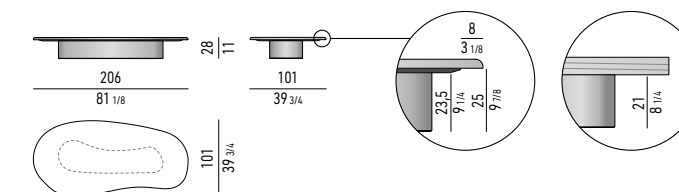

PIANO TOP

PIETRA
STONE

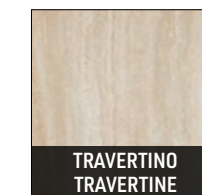

MARMO
MARBLE



NOCE CANALETTO
CANALETTO WALNUT

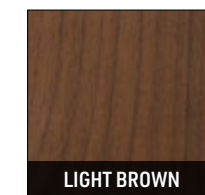

BASE BASE

METALLO LUCIDO
POLISHED METAL

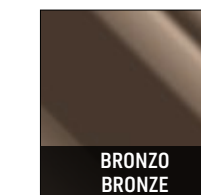

METALLO MATERICO
TEXTURED METAL

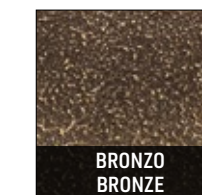

YVES COFFEE TABLE

HANNES PEER DESIGN



TAVOLINI | COFFEE TABLES

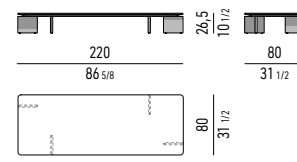
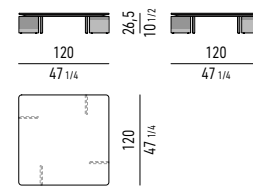
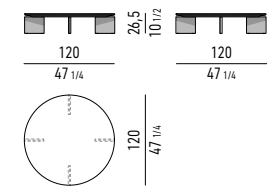

CONSOLLE | CONSOLE TABLE

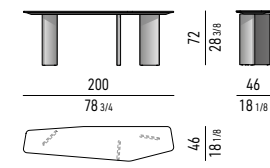

NASTRO

GIAMPIERO TAGLIAFERRI DESIGN



TAVOLINI | COFFEE TABLES

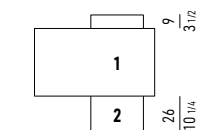
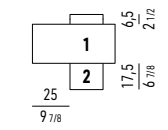
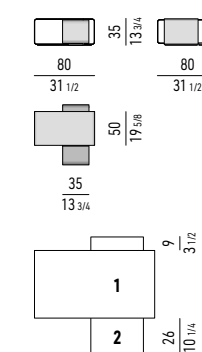
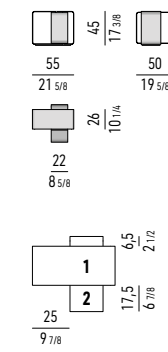

CONSOLLE | CONSOLE TABLES

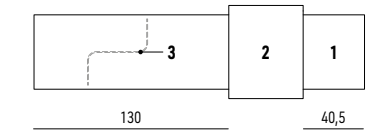
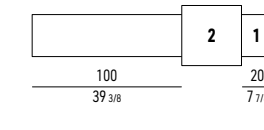
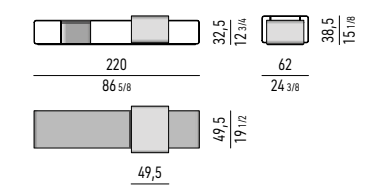
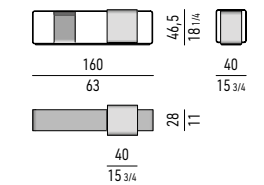

COMBINAZIONE "A" | COMBINATION "A"

ANELLO 1 | RING 1

FINITURA ESTERNA
EXTERNAL FINISH

METALLO SATINATO PROFONDO
DEEP SATIN METAL

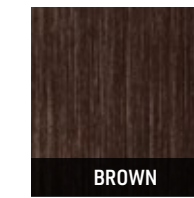

FINITURA INTERNA
INTERNAL FINISH

METALLO LUCIDO
POLISHED METAL

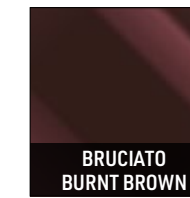

ANELLO 2 | RING 2

FINITURA ESTERNA E INTERNA
EXTERNAL AND INTERNAL FINISH

METALLO LUCIDO
POLISHED METAL

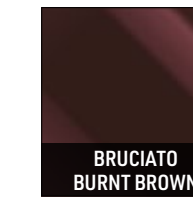

ELEMENTO 3 | ELEMENT 3

FINITURA ESTERNA E INTERNA
EXTERNAL AND INTERNAL FINISH

METALLO SATINATO PROFONDO
DEEP SATIN METAL

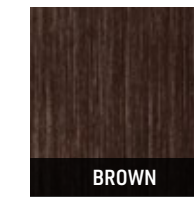

SOLO PER CONSOLLE | ONLY FOR CONSOLE TABLES

COMBINAZIONE "B" | COMBINATION "B"

ANELLO 1 | RING 1

FINITURA ESTERNA
EXTERNAL FINISH

ACCIAIO SATINATO
SATIN STEEL



FINITURA INTERNA
INTERNAL FINISH

ACCIAIO INOX
STAINLESS STEEL



ANELLO 2 | RING 2

FINITURA ESTERNA
EXTERNAL FINISH

ACCIAIO LUCIDO
POLISHED STEEL



FINITURA INTERNA
INTERNAL FINISH

ACCIAIO INOX
STAINLESS STEEL



ELEMENTO 3 | ELEMENT 3

FINITURA ESTERNA E INTERNA
EXTERNAL AND INTERNAL FINISH

ACCIAIO LUCIDO
POLISHED STEEL



SOLO PER CONSOLLE | ONLY FOR CONSOLE TABLES

COMBINAZIONE "C" | COMBINATION "C" - SOLO PER CONSOLLE CM 220X62 H38,5 | ONLY FOR CM 220X62 H38,5 CONSOLE TABLE

ANELLO 1 | RING 1

FINITURA ESTERNA
EXTERNAL FINISH

FRASSINO
ASH



FINITURA INTERNA
INTERNAL FINISH

METALLO LUCIDO
POLISHED METAL



ANELLO 2 | RING 2

FINITURA ESTERNA
EXTERNAL FINISH

ACCIAIO LUCIDO
POLISHED STEEL



FINITURA INTERNA
INTERNAL FINISH

ACCIAIO INOX
STAINLESS STEEL



ELEMENTO 3 | ELEMENT 3

FINITURA ESTERNA E INTERNA
EXTERNAL AND INTERNAL FINISH

ACCIAIO LUCIDO
POLISHED STEEL



GAMBE LEGS

ALLUMINIO LUCIDO POLISHED ALUMINIUM

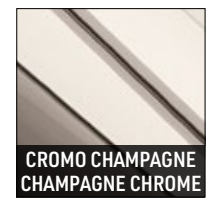

DISPONIBILE SOLO PER PIANI IN MARMO GRIGIO OROBICO E PIERRE BLEUE
AVAILABLE ONLY FOR GRIGIO OROBICO AND PIERRE BLEUE MARBLE TOPS

PIANO TOP

PIETRA STONE

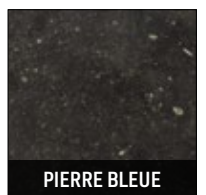

MARMO MARBLE

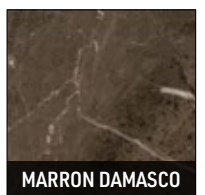
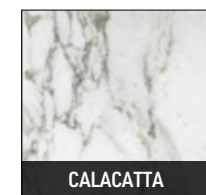

NOCE CANALETTO CANALETTO WALNUT

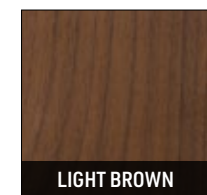

CAMEO

HANNES PEER DESIGN

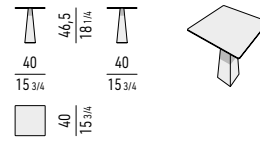

STRUTTURA
STRUCTURE

ACCIAIO LUCIDO
POLISHED STEEL



ALLUMINIO LUCIDO
POLISHED ALUMINIUM



METALLO SATINATO PROFONDO
DEEP SATIN METAL

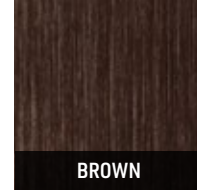

HELENE (UPDATE)

HANNES PEER DESIGN

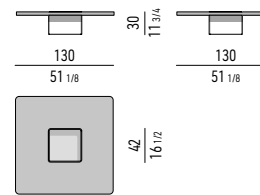
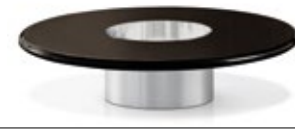

SPAZIO UTILE VANO PORTA OGGETTI: CM 42X42 H9,5
TRAY INSERT INTERNAL DIMENSION: CM 42X42 H9,5

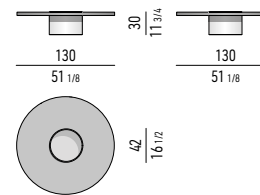

SPAZIO UTILE VANO PORTA OGGETTI: CM Ø 48 H9,5
TRAY INSERT INTERNAL DIMENSION: CM Ø 48 H9,5

PIANO
TOP

NOCE CANALETTO
CANALETTO WALNUT

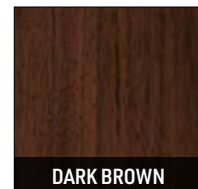

BORDO
EDGE

LACCATO LUCIDO
GLOSSY LACQUERED



PIANO / BORDO
TOP / EDGE

FRASSINO
ASH



PIANO / BORDO
TOP / EDGE

LACCATO LUCIDO
GLOSSY LACQUERED



NEW 2025 FINISH

NEW 2025 FINISH

BASE / VANO PORTA OGGETTI
BASE / INSERTED TRAY ELEMENT

ACCIAIO LUCIDO
POLISHED STEEL



SUPERFICIE D'APPOGGIO VANO PORTA OGGETTI
TOP SURFACE OF THE INSERTED TRAY ELEMENT

SPECCHIO
MIRROR

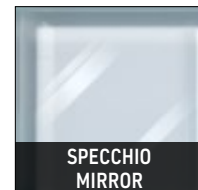

FILL (UPDATE)

HANNES PEER DESIGN



TAVOLINI | COFFEE TABLES

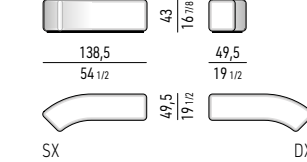
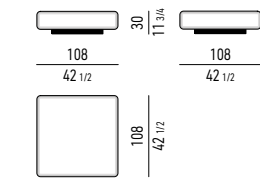
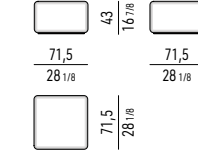
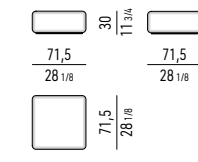
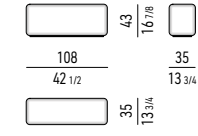
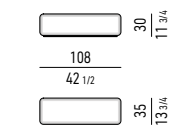
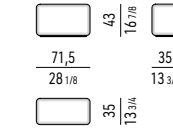
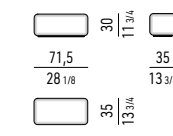
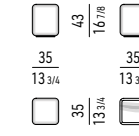

COMODINI | NIGHTSTANDS

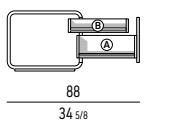
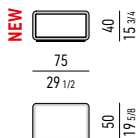
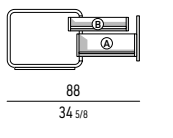
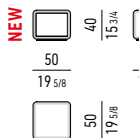

DOTAZIONE

- Nr. 1 cassetto (A) che scorre su guide a estrazione totale con chiusura Blumotion. Portata massima per cassetto Kg 30.

DOTAZIONE INTERNA

- Nr. 1 cassetto (B) che scorre su guide a estrazione totale con chiusura Blumotion. Portata massima per cassetto Kg 30.

Spazio utile interno cassetti

(A): cm 34x37 H12
(B): cm 34x37 H5,5

EQUIPMENT

- Nr. 1 drawer (A) that glide on fully extractable guides with Blumotion soft-close system. Maximum load per drawer is 30 kg.

INTERIOR EQUIPMENT

- Nr. 1 drawer (B) that glide on fully extractable guides with Blumotion soft-close system. Maximum load per drawer is 30 kg.

Drawer internal dimension

(A): cm 34x37 H12
(B): cm 34x37 H5,5

DOTAZIONE

- Nr. 1 cassetto (A) che scorre su guide a estrazione totale con chiusura Blumotion. Portata massima per cassetto Kg 30.

DOTAZIONE INTERNA

- Nr. 1 cassetto (B) che scorre su guide a estrazione totale con chiusura Blumotion. Portata massima per cassetto Kg 30.

Spazio utile interno cassetti

(A): cm 59x37 H12
(B): cm 59x37 H5,5

EQUIPMENT

- Nr. 1 drawer (A) that glide on fully extractable guides with Blumotion soft-close system. Maximum load per drawer is 30 kg.

INTERIOR EQUIPMENT

- Nr. 1 drawer (B) that glide on fully extractable guides with Blumotion soft-close system. Maximum load per drawer is 30 kg.

Drawer internal dimension

(A): cm 59x37 H12
(B): cm 59x37 H5,5

CONTENITORE NOTTE | NIGHT SIDEBOARD

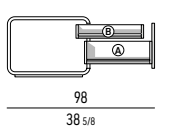
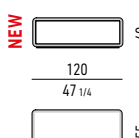

DOTAZIONE

- Nr. 1 cassetto (A) che scorre su guide a estrazione totale con chiusura Blumotion. Portata massima per cassetto Kg 30.

DOTAZIONE INTERNA

- Nr. 1 cassetto (B) che scorre su guide a estrazione totale con chiusura Blumotion. Portata massima per cassetto Kg 30.

Spazio utile interno cassetti

(A): cm 104x42 H12
(B): cm 104x42 H5,5

EQUIPMENT

- Nr. 1 drawer (A) that glide on fully extractable guides with Blumotion soft-close system. Maximum load per drawer is 30 kg.

INTERIOR EQUIPMENT

- Nr. 1 drawer (B) that glide on fully extractable guides with Blumotion soft-close system. Maximum load per drawer is 30 kg.

Drawer internal dimension

(A): cm 104x42 H12
(B): cm 104x42 H5,5

TAVOLINO | COFFEE TABLE CM 35X35 H43

STRUTTURA
STRUCTURE

MARMO
MARBLE

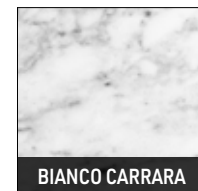
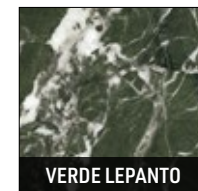
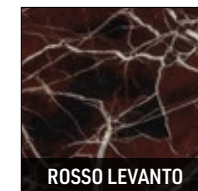

TAVOLINI E COMODINI | COFFEE TABLES AND NIGHTSTANDS

STRUTTURA
STRUCTURE

LACCATO LUCIDO
GLOSSY LACQUERED

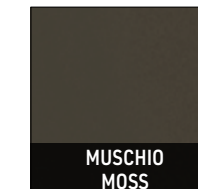

NEW 2025 FINISH

BASE
BASE

METALLO LUCIDO
POLISHED METAL

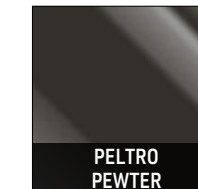

SOLO PER TAVOLINO CM 108X108 H30
ONLY FOR CM 108X108 H30 COFFEE TABLE

CASSETTI INTERNI
INTERNAL DRAWERS

FRASSINO
ASH



FONDO CASSETTI
DRAWERS BOTTOM

CUOIO
SADDLE-HIDE

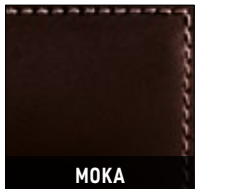

TAIKO (UPDATE) NENDO DESIGN

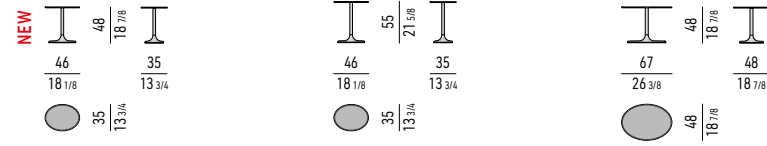

PIANO E BASE TOP AND BASE

ALLUMINIO LUCIDO
POLISHED ALUMINIUM

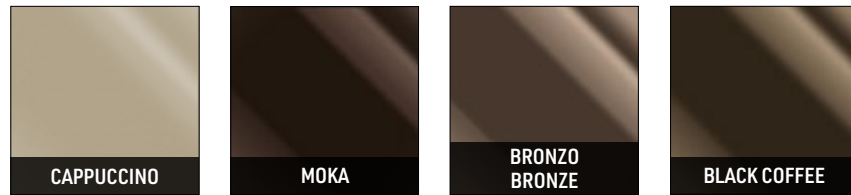

NEW 2025 FINISH

NEW 2025 FINISH

LINHA LIVRE MARCIO KOGAN / STUDIO MK27 DESIGN

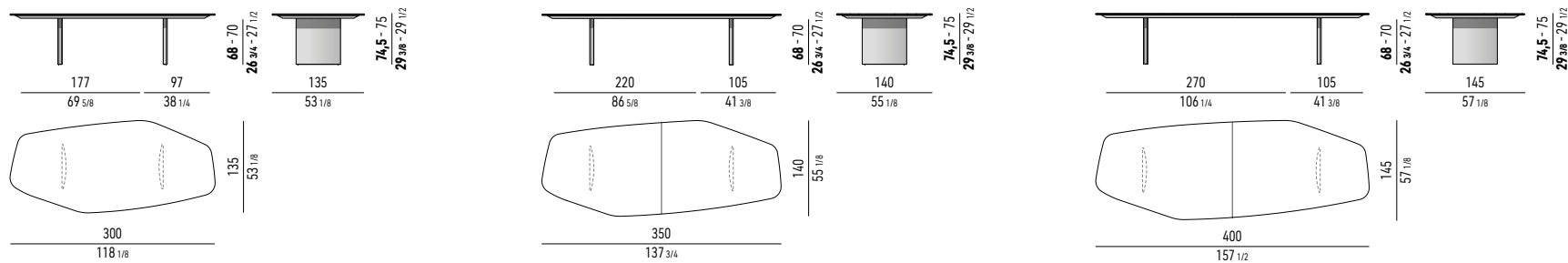

N.B.: I PIANI IN PIETRA SONO DIVISI IN DUE PARTI COME DA DISEGNO, LA STRUTTURA PORTANTE È SEMPRE UN PEZZO UNICO.
N.B.: THE TOPS IN STONE ARE DIVIDED INTO TWO PIECES AS PER DRAWING, THE LOADBEARING STRUCTURE IS A SINGLE PIECE.

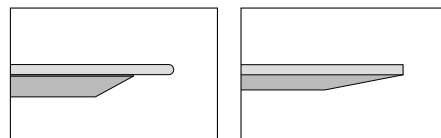

PIANO MARMO / MARBLE TOP
H CM 74,5

PIANO LEGNO / WOOD TOP
H CM 75

PIANO TOP

PIETRA
STONE



TRAVERTINO
TRAVERTINE

MARMO
MARBLE



PIERRE BLEUE

NOCE CANALETTO
CANALETTO WALNUT

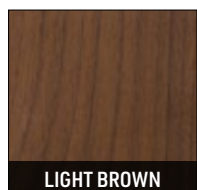

GRIGIO OROBICO

LIGHT BROWN

GAMBE LEGS

LEGNO
WOOD



BRONZO PATINATO
ANTIQUÉ BRONZE

LIBRA TABLE GIAMPIERO TAGLIAFERRI DESIGN

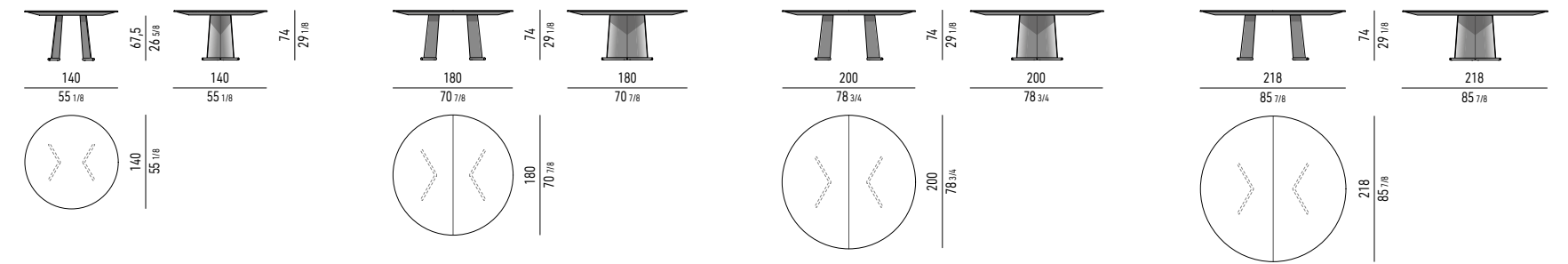

N.B.: I PIANI SONO DIVISI IN DUE PARTI COME DA DISEGNO, LA STRUTTURA PORTANTE È SEMPRE UN PEZZO UNICO.
N.B.: THE TOPS ARE DIVIDED INTO TWO PIECES AS PER DRAWING, THE LOADBEARING STRUCTURE IS A SINGLE PIECE.

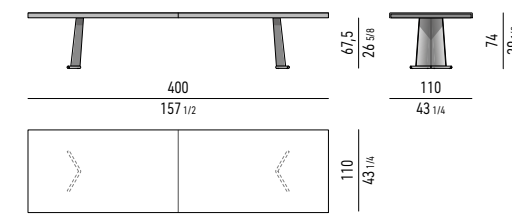
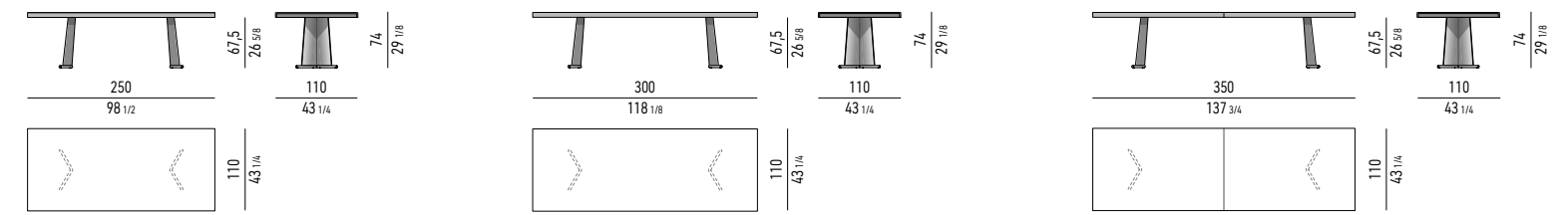

N.B.: I PIANI SONO DIVISI IN DUE PARTI COME DA DISEGNO, LA STRUTTURA PORTANTE È SEMPRE UN PEZZO UNICO.
N.B.: THE TOPS ARE DIVIDED INTO TWO PIECES AS PER DRAWING, THE LOADBEARING STRUCTURE IS A SINGLE PIECE.

LIBRA LAZY SUSAN

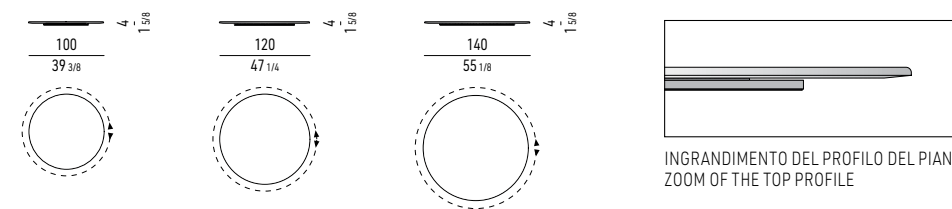

INGRANDIMENTO DEL PROFILO DEL PIANO
ZOOM OF THE TOP PROFILE

PIANO TAVOLO E LIBRA LAZY SUSAN TABLE TOP AND LIBRA LAZY SUSAN

PIETRA
STONE



TRAVERTINO
TRAVERTINE

MARMO
MARBLE



GIALLO SIENA

GRANITO
GRANITE



CALACATTA

NOCE CANALETTO
CANALETTO WALNUT

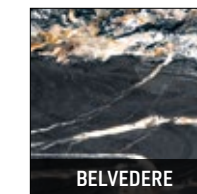

BELVEDERE

FRASSINO
ASH

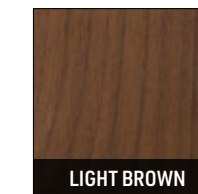

LIGHT BROWN

METALLO LUCIDO
POLISHED METAL



LIQUIRIZIA
LICORICE

FASCIA LATERALE SIDE STRIP

METALLO LUCIDO
POLISHED METAL



CROMO
CHROME

GAMBE LEGS

METALLO OPACO
MATT METAL

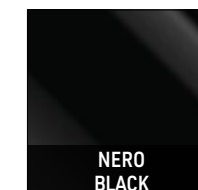

NERO
BLACK

BARRE CILINDRICHE CYLINDRICAL BARS

METALLO LUCIDO
POLISHED METAL



CROMO
CHROME

GAMBE LEGS

METALLO SATINATO PROFONDO
DEEP SATIN METAL

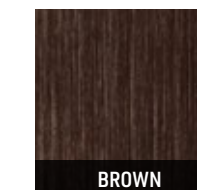

BROWN

BARRE CILINDRICHE CYLINDRICAL BARS

METALLO LUCIDO
POLISHED METAL

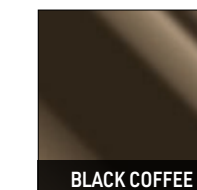

BLACK COFFEE

GAMBE LEGS

NOCE CANALETTO
CANALETTO WALNUT

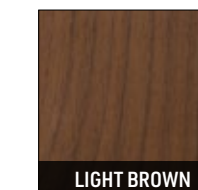

LIGHT BROWN

BARRE CILINDRICHE CYLINDRICAL BARS

METALLO LUCIDO
POLISHED METAL

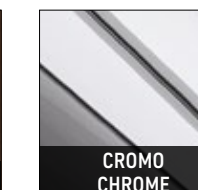

CROMO
CHROME

NON DISPONIBILE ABBINAMENTO CON PIANO IN FRASSINO LIQUIRIZIA
NOT AVAILABLE COMBINATION WITH LICORICE ASH TOP

SAKI TABLE

NENDO DESIGN

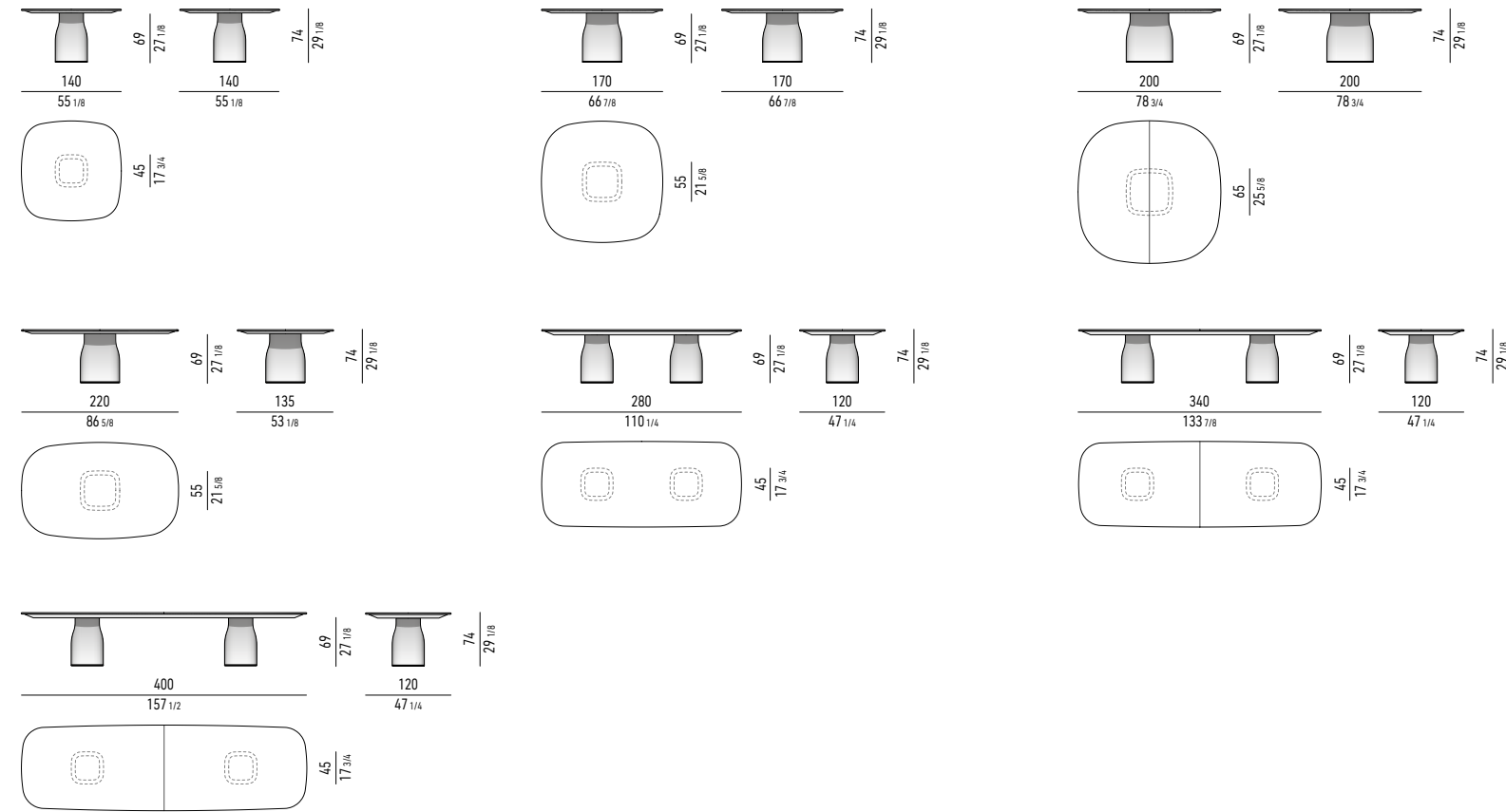

N.B.: I PIANI SONO DIVISI IN DUE PARTI COME DA DISEGNO, LA STRUTTURA PORTANTE È SEMPRE UN PEZZO UNICO.
N.B.: THE TOPS ARE DIVIDED INTO TWO PIECES AS PER DRAWING, THE LOADBEARING STRUCTURE IS A SINGLE PIECE.

DIAGRAMMA SIDEBOARD

GIAMPIERO TAGLIAFERRI DESIGN

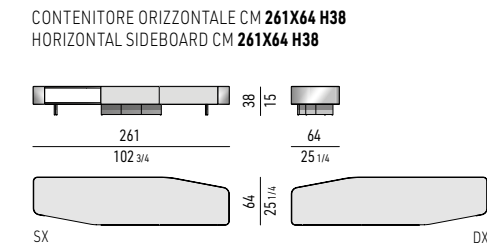

DOTAZIONE
 - Nr. 2 cassettoni che scorrono su guida a estrazione totale con chiusura Blumotion. Portata massima per cassetto Kg 30;
 - Nr. 1 vano a giorno.

Spazio utile interno cassetti
 cm 70,5x37 H13

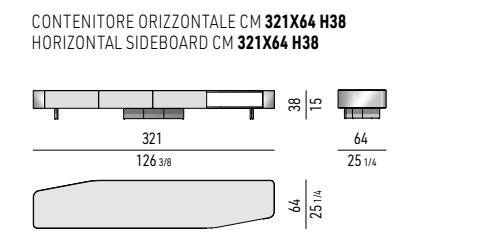

DOTAZIONE
 - Nr. 3 cassettoni che scorrono su guida a estrazione totale con chiusura Blumotion. Portata massima per cassetto Kg 30;
 - Nr. 1 vano a giorno.

Spazio utile interno cassetti
 cm 64,5x37 H13

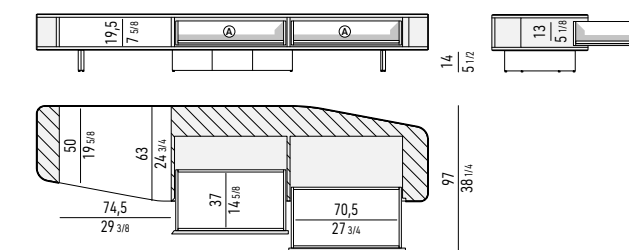

EQUIPMENT
 - Nr. 2 large drawers that glide on fully extractable guides with Blumotion soft-close system. Maximum load per drawer is 30 kg;
 - Nr. 1 open compartment.

Drawers internal dimension
 cm 70,5x36 H13

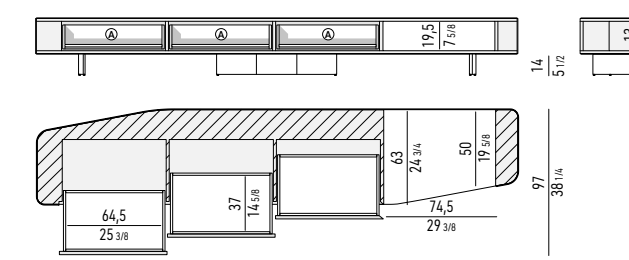

EQUIPMENT
 - Nr. 3 large drawers that glide on fully extractable guides with Blumotion soft-close system. Maximum load per drawer is 30 kg;
 - Nr. 1 open compartment.

Drawers internal dimension
 cm 64,5x37 H13

PIANO TOP
MARMO MARBLE

 CALACATTA

BASE BASE
LACCATO LUCIDO GLOSSY LACQUERED

 WARM GREY

PIANO TOP
PIETRA STONE

 PIERRE BLEUE

BASE BASE
LACCATO LUCIDO GLOSSY LACQUERED

 MOKA

PIASTRE PLATES
METALLO LUCIDO POLISHED METAL

 CROMO CHROME

STRUTTURA INTERNA / ESTERNA INTERNAL / EXTERNAL STRUCTURE
LACCATO LUCIDO GLOSSY LACQUERED

 CAPPUCCINO

MOKA

STRUTTURA CASSETTONI LARGE DRAWERS STRUCTURE
LACCATO OPACO MATT LACQUERED

 CAPPUCCINO

MOKA

GAMBE E FIANCHI LEGS AND SIDES
ACCIAIO LUCIDO POLISHED STEEL

 ACCIAIO INOX STAINLESS STEEL

YVES SIDEBORD

HANNES PEER DESIGN



CONTENITORI ORIZZONTALI LIVING | LIVING HORIZONTAL SIDEBOARD

CONTENITORE ORIZZONTALE CM 230,5X54 H48
HORIZONTAL SIDEBOARD CM 230,5X54 H48

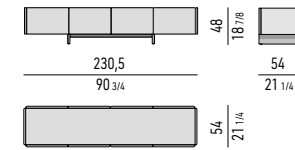

DOTAZIONE
- Nr. 4 cassettoni che scorrono su guide a estrazione totale con chiusura Blumotion. Portata massima per cassetto Kg 30.
Spazio utile interno cassetti
cm 46x37 H22

EQUIPMENT
- Nr. 4 large drawers that glide on fully extractable guides with Blumotion soft-close system. Maximum load per drawer is 30 kg.
Drawers internal dimension
cm 46x37 H22

CONTENITORE ORIZZONTALE CM 287X54 H48
HORIZONTAL SIDEBOARD CM 287X54 H48

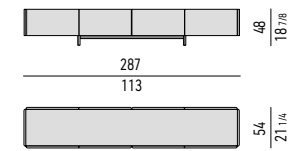

DOTAZIONE
- Nr. 4 cassettoni che scorrono su guide a estrazione totale con chiusura Blumotion. Portata massima per cassetto Kg 30.
Spazio utile interno cassetti
cm 61x37 H22

EQUIPMENT
- Nr. 4 large drawers that glide on fully extractable guides with Blumotion soft-close system. Maximum load per drawer is 30 kg.
Drawers internal dimension
cm 61x37 H22

CONTENITORE ORIZZONTALE CM 357X54 H48
HORIZONTAL SIDEBOARD CM 357X54 H48

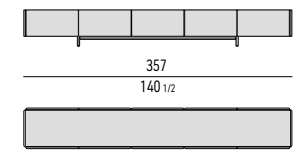

DOTAZIONE
- Nr. 5 cassettoni che scorrono su guide a estrazione totale con chiusura Blumotion. Portata massima per cassetto Kg 30.
Spazio utile interno cassetti
cm 61x37 H22

EQUIPMENT
- Nr. 5 large drawers that glide on fully extractable guides with Blumotion soft-close system. Maximum load per drawer is 30 kg.
Drawers internal dimension
cm 61x37 H22

STRUTTURA ESTERNA EXTERNAL STRUCTURE	STRUTTURA INTERNA INTERNAL STRUCTURE	PIANO TOP		
FRASSINO ASH	LACCATO OPACO MATT LACQUERED	MARMO MARBLE	PIETRA STONE	FRASSINO ASH
NERO BLACK	MOKA	BIANCO CARRARA	PIERRE BLEUE	NERO BLACK

STRUTTURA ESTERNA EXTERNAL STRUCTURE	STRUTTURA INTERNA INTERNAL STRUCTURE	PIANO TOP		
LACCATO LUCIDO GLOSSY LACQUERED	LACCATO OPACO MATT LACQUERED	MARMO MARBLE	PIETRA STONE	LACCATO LUCIDO GLOSSY LACQUERED
CAPPUCCINO	CAPPUCCINO	BIANCO CARRARA	PIERRE BLEUE	CAPPUCCINO

STRUTTURA ESTERNA EXTERNAL STRUCTURE	STRUTTURA INTERNA INTERNAL STRUCTURE	PIANO TOP			NOCE CANALETTO CANALETTO WALNUT
LACCATO LUCIDO GLOSSY LACQUERED	LACCATO OPACO MATT LACQUERED	MARMO MARBLE	PIETRA STONE	LACCATO LUCIDO GLOSSY LACQUERED	
MOKA	MOKA	BIANCO CARRARA	PIERRE BLEUE	MOKA	DARK BROWN

CONTENITORI ORIZZONTALI DINING | DINING HORIZONTAL SIDEBOARD

CONTENITORE ORIZZONTALE CM 230,5X54 H63
HORIZONTAL SIDEBOARD CM 230,5X54 H63

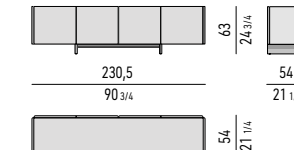

VASSOIO PORTAPOSATE | CUTLERY TRAY
cm 51x37 H3,5
Scomparto grande | Big section: 49,5x9,5 H2,5
Scomparto piccolo | Small section: 24,5x8 H2,5

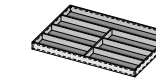

CONTENITORE ORIZZONTALE CM 287X54 H63
HORIZONTAL SIDEBOARD CM 287X54 H63

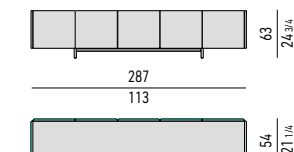

VASSOIO PORTAPOSATE | CUTLERY TRAY
cm 51x37 H3,5
Scomparto grande | Big section: 49,5x9,5 H2,5
Scomparto piccolo | Small section: 24,5x8 H2,5

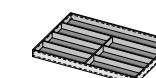

STRUTTURA ESTERNA EXTERNAL STRUCTURE	STRUTTURA INTERNA INTERNAL STRUCTURE	PIANO TOP		
NOCE CANALETTO CANALETTO WALNUT	LACCATO OPACO MATT LACQUERED	MARMO MARBLE	PIETRA STONE	NOCE CANALETTO CANALETTO WALNUT
DARK BROWN	MOKA	BIANCO CARRARA	PIERRE BLEUE	DARK BROWN

STRUTTURA ESTERNA EXTERNAL STRUCTURE	STRUTTURA INTERNA INTERNAL STRUCTURE	PIANO TOP		
NOCE CANALETTO CANALETTO WALNUT	LACCATO OPACO MATT LACQUERED	MARMO MARBLE	PIETRA STONE	NOCE CANALETTO CANALETTO WALNUT
LIGHT BROWN	MOKA	BIANCO CARRARA	PIERRE BLEUE	LIGHT BROWN

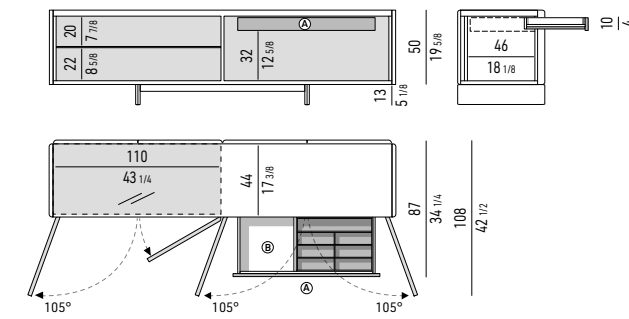

DOTAZIONE
- Nr. 4 ante.
DOTAZIONE INTERNA
- Nr. 1 cassetto (A) che scorre su guide a estrazione totale con chiusura Blumotion. Portata massima per cassetto Kg 30;
- Nr. 1 ripiano in vetro bronzato temperato, spessore mm 8;
- Nr. 1 vassoio portaposate in cuoio color Nero dotato di divisori, riposto nel cassetto (A).
Spazio utile interno cassetto
Scomparto (B): cm 36x37 H4,5

EQUIPMENT
- Nr. 4 doors.
INTERIOR EQUIPMENT
- Nr. 1 drawer (A) that glide on fully extractable guides with Blumotion soft-close system. Maximum load per drawer is 30 kg;
- Nr. 1 bronzed tempered glass shelf, mm 8 thick.
- Nr. 1 cutlery tray in Black colour saddle-hide, with dividers, located in the (A) drawer.
Drawer internal dimension
Section (B): cm 36x37 H4,5

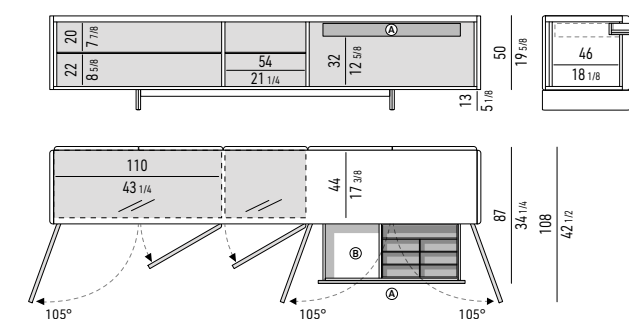

DOTAZIONE
- Nr. 5 ante.
DOTAZIONE INTERNA
- Nr. 1 cassetto (A) che scorre su guide a estrazione totale con chiusura Blumotion. Portata massima per cassetto Kg 30;
- Nr. 2 ripiani in vetro bronzato temperato, spessore mm 8;
- Nr. 1 vassoio portaposate in cuoio color Nero dotato di divisori, riposto nel cassetto (A).
Spazio utile interno cassetto
Scomparto (B): cm 36x37 H4,5

EQUIPMENT
- Nr. 5 doors.
INTERIOR EQUIPMENT
- Nr. 1 drawer (A) that glide on fully extractable guides with Blumotion soft-close system. Maximum load per drawer is 30 kg;
- Nr. 2 bronzed tempered glass shelves, mm 8 thick.
- Nr. 1 cutlery tray in Black colour saddle-hide, with dividers, located in the (A) drawer.
Drawer internal dimension
Section (B): cm 36x37 H4,5

CONTENITORE DINING | DINING SIDEBOARD

RIPIANO INTERNO INTERNAL SHELF	VASSOIO PORTA POSATE CUTLERY TRAY
VETRO GLASS	CUOIO SADDLE-HIDE
BRONZATO BRONZED	NERO BLACK

LIBRA SIDEBORD

GIAMPIERO TAGLIAFERRI DESIGN



CONTENITORI ORIZZONTALI LIVING | LIVING HORIZONTAL SIDEBORD

CONTENITORE ORIZZONTALE CM 241,5X55,5 H45
HORIZONTAL SIDEBORD CM 241,5X55,5 H45

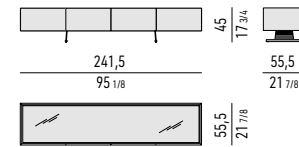

DOTAZIONE

- Nr. 4 cassettoni che scorrono su guide a estrazione totale con chiusura Blumotion. Portata massima per cassetto Kg 30.

Spazio utile interno cassetti
cm 51x43 H17

EQUIPMENT

- Nr. 4 large drawers that glide on fully extractable guides with Blumotion soft-close system. Maximum load per drawer is 30 kg.

Drawers internal dimension
cm 51x43 H17

CONTENITORE ORIZZONTALE CM 301,5X55,5 H45
HORIZONTAL SIDEBORD CM 301,5X55,5 H45

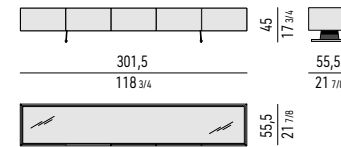

DOTAZIONE

- Nr. 5 cassettoni che scorrono su guide a estrazione totale con chiusura Blumotion. Portata massima per cassetto Kg 30.

Spazio utile interno cassetti
cm 51x43 H17

EQUIPMENT

- Nr. 5 large drawers that glide on fully extractable guides with Blumotion soft-close system. Maximum load per drawer is 30 kg.

Drawers internal dimension
cm 51x43 H17

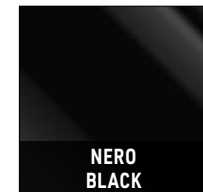
GAMBE
LEGSMETALLO OPACO
MATT METALNERO
BLACKBARRE CILINDRICHE
CYLINDRICAL BARSMETALLO LUCIDO
POLISHED METALCROMO
CHROME

CONTENITORE DINING | DINING SIDEBORD

CASSETTI E INTERNO CASSETTONI
DRAWERS AND INTERNAL LARGE DRAWERS

FRASSINO
ASHLIQUIRIZIA
LICORICE

VASSOIO PORTA POSATE E FONDO DEL VANO
CUTLERY TRAY AND COMPARTMENT BOTTOM

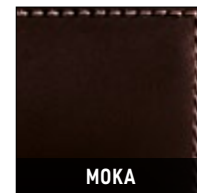
CUOIO
SADDLE-HIDE

MOKA

RIPIANO INTERNO
INTERNAL SHELF

VETRO
GLASSGRIGIO FUMÉ
SMOKED GREY

STRUTTURA ESTERNA ED INTERNA
EXTERNAL AND INTERNAL STRUCTURE

LACCATO LUCIDO
GLOSSY LACQUERED

MOKA

PIANO
TOP

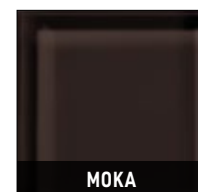
VETRO RETROVERNICIATO
BACKPAINTED GLASS

MOKA

STRUTTURA ESTERNA ED INTERNA
EXTERNAL AND INTERNAL STRUCTURE

LACCATO LUCIDO
GLOSSY LACQUERED

CAPPUCCINO

PIANO
TOP

VETRO RETROVERNICIATO
BACKPAINTED GLASS

CAPPUCCINO

CONTENITORI ORIZZONTALI DINING | DINING HORIZONTAL SIDEBORD

CONTENITORE ORIZZONTALE CM 241,5X55,5 H65
HORIZONTAL SIDEBORD CM 241,5X55,5 H65

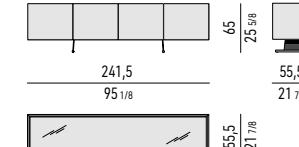

VASSOIO PORTAPOSATE | CUTLERY TRAY
cm 51x37 H3,5

Scomparto grande | Big section: 49,5x9,5 H2,5
Scomparto piccolo | Small section: 24,5x8 H2,5

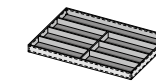

CONTENITORE ORIZZONTALE CM 301,5X55,5 H65
HORIZONTAL SIDEBORD CM 301,5X55,5 H65

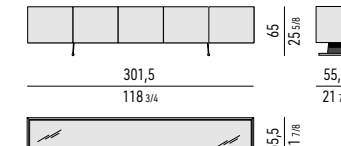

VASSOIO PORTAPOSATE | CUTLERY TRAY
cm 51x37 H3,5

Scomparto grande | Big section: 49,5x9,5 H2,5
Scomparto piccolo | Small section: 24,5x8 H2,5

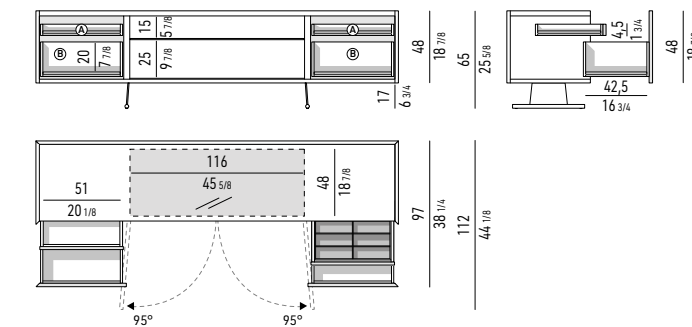
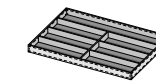

DOTAZIONE

- Nr. 2 ante;
- Nr. 2 cassettoni che scorrono su guide a estrazione totale con chiusura Blumotion. Portata massima per cassetto Kg 30.

DOTAZIONE INTERNA

- Nr. 4 cassetti (A, B) che scorrono su guide a estrazione totale con chiusura Blumotion. Portata massima per cassetto Kg 30;
- Nr. 1 ripiano in vetro temperato Grigio Fumè, spessore mm 8;
- Nr. 1 vassoio portaposate in cuoio color Nero dotato di divisori, riposto nel cassetto (A).

Spazio utile interno cassetti

(A): cm 51,5x37 H4,5
(B): cm 51x42,5 H20

EQUIPMENT

- Nr. 2 doors;
- Nr. 2 large drawers that glide on fully extractable guides with Blumotion soft-close system. Maximum load per drawer is 30 Kg.

INTERIOR EQUIPMENT

- Nr. 4 drawers (A, B) that glide on fully extractable guides with Blumotion soft-close system. Maximum load per drawer is 30 kg;
- Nr. 1 tempered Smoked Grey glass shelf, mm 8 thick;
- Nr. 1 cutlery tray in Black colour saddle-hide, with dividers, located in the (A) drawer.

Drawer internal dimension

(A): cm 51,5x37 H4,5
(B): cm 51x42,5 H20

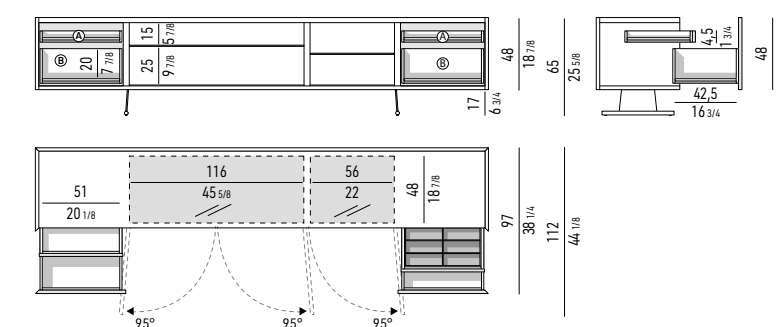

DOTAZIONE

- Nr. 3 ante;
- Nr. 2 cassettoni che scorrono su guide a estrazione totale con chiusura Blumotion. Portata massima per cassetto Kg 30.

DOTAZIONE INTERNA

- Nr. 4 cassetti (A, B) che scorrono su guide a estrazione totale con chiusura Blumotion. Portata massima per cassetto Kg 30;
- Nr. 2 ripiani in vetro temperato Grigio Fumè, spessore mm 8;
- Nr. 1 vassoio portaposate in cuoio color Nero dotato di divisori, riposto nel cassetto (A).

Spazio utile interno cassetti

(A): cm 51,5x37 H4,5
(B): cm 51x42,5 H20

EQUIPMENT

- Nr. 3 doors;
- Nr. 2 large drawers that glide on fully extractable guides with Blumotion soft-close system. Maximum load per drawer is 30 Kg.

INTERIOR EQUIPMENT

- Nr. 4 drawers (A, B) that glide on fully extractable guides with Blumotion soft-close system. Maximum load per drawer is 30 kg;
- Nr. 2 tempered Smoked Grey glass shelves, mm 8 thick;
- Nr. 1 cutlery tray in Black colour saddle-hide, with dividers, located in the (A) drawer.

Drawer internal dimension

(A): cm 51,5x37 H4,5
(B): cm 51x42,5 H20

SUPERBLOCKS (UPDATE) MARCIO KOGAN / STUDIO MK27 DESIGN



CONTENITORI "LIVING" | "LIVING" SIDEBARDS

CONTENITORE **LIVING** CON 2 CASSETTONI E 2 CASSETTI - **MOD. A**
LIVING SIDEBOARD WITH 2 LARGE DRAWERS AND 2 SMALL DRAWERS - **MOD. A**

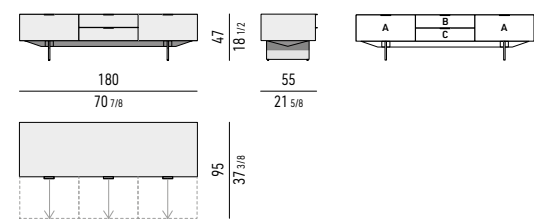

DOTAZIONE

Nr. 2 cassettoni **(A)** e 2 cassetti **(B, C)** che scorrono su guide a estrazione totale con chiusura Blumotion. Portata massima per cassetto Kg 30.

Spazio utile interno cassetti
(A): cm 51x42 H14
(B): cm 51x42 H6
(C): cm 51x42 H4

EQUIPMENT

Nr. 2 large drawers **(A)** and 2 small drawers **(B, C)** that glide on fully extractable guides with Blumotion soft-close system. Maximum load per drawer is 30 Kg.

Drawers internal dimension
(A): cm 51x42 H14
(B): cm 51x42 H6
(C): cm 51x42 H4

CONTENITORE **LIVING** CON 4 CASSETTONI - **MOD. B**
LIVING SIDEBOARD WITH 4 LARGE DRAWERS - **MOD. B**

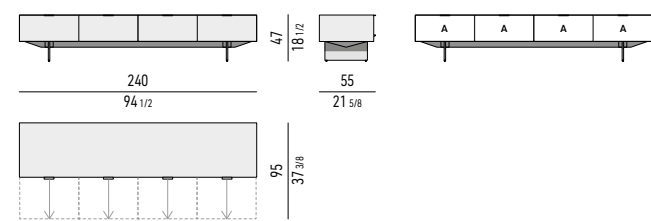

DOTAZIONE

Nr. 4 cassettoni che scorrono su guide a estrazione totale con chiusura Blumotion. Portata massima per cassetto Kg 30.

Spazio utile interno cassettoni
(A): cm 51x42 H14

EQUIPMENT

Nr. 4 large drawers that glide on fully extractable guides with Blumotion soft-close system. Maximum load per drawer is 30 Kg.

Large drawers internal dimension
(A): cm 51x42 H14

CONTENITORE **LIVING** CON 2 CASSETTONI E 4 CASSETTI - **MOD. C**
LIVING SIDEBOARD WITH 2 LARGE DRAWERS AND 4 SMALL DRAWERS - **MOD. C**

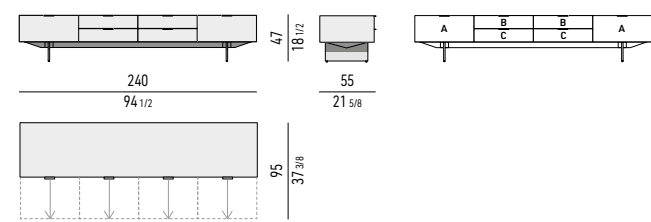

DOTAZIONE

Nr. 2 cassettoni **(A)** e 4 cassetti **(B, C)** che scorrono su guide a estrazione totale con chiusura Blumotion. Portata massima per cassetto Kg 30.

Spazio utile interno cassetti
(A): cm 51x42 H14
(B): cm 51x42 H6
(C): cm 51x42 H4

EQUIPMENT

Nr. 2 large drawers **(A)** and 4 small drawers **(B, C)** that glide on fully extractable guides with Blumotion soft-close system. Maximum load per drawer is 30 Kg.

Drawers internal dimension
(A): cm 51x42 H14
(B): cm 51x42 H6
(C): cm 51x42 H4

STRUTTURA E INTERNO CASSETTI
STRUCTURE AND INTERNAL DRAWERS



STRUTTURA
STRUCTURE

LACCATO LUCIDO
GLOSSY LACQUERED



INTERNO CASSETTI
INTERNAL DRAWERS

FRASSINO
ASH



CONTENITORE **LIVING** CON 4 CASSETTI ED ELEMENTO IN MARMO - **MOD. D**
LIVING SIDEBOARD WITH 4 SMALL DRAWERS AND MARBLE ELEMENT - **MOD. D**

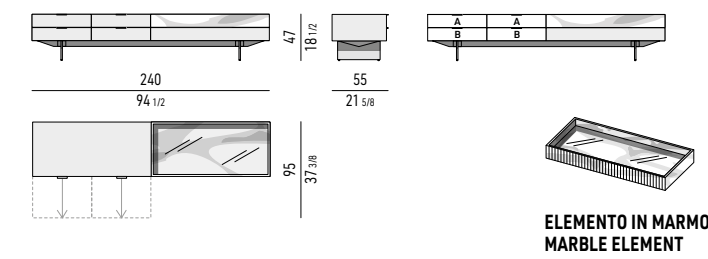

DOTAZIONE

Nr. 4 cassetti **(A, B)** che scorrono su guide a estrazione totale con chiusura Blumotion. Portata massima per cassetto Kg 30. Elemento in marmo.

Elemento in marmo: cm 120x55 H13
Spazio utile interno: cm 116x51 H6
Spazio utile interno cassetti
(A): cm 51x42 H6
(B): cm 51x42 H4

EQUIPMENT

Nr. 4 small drawers **(A, B)** that glide on fully extractable guides with Blumotion soft-close system. Maximum load per drawer is 30 Kg. Marble element.

Marble element: cm 120x55 H13
Internal dimension: cm 116x51 H6
Drawers internal dimension
(A): cm 51x42 H6
(B): cm 51x42 H4

CONTENITORE **LIVING** CON 2 CASSETTONI ED ELEMENTO IN MARMO - **MOD. E**
LIVING SIDEBOARD WITH 2 LARGE DRAWERS AND MARBLE ELEMENT - **MOD. E**

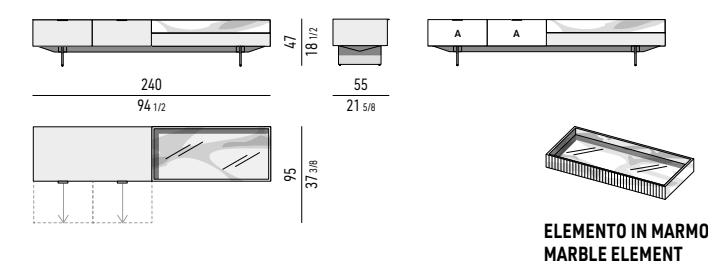

DOTAZIONE

Nr. 2 cassettoni che scorrono su guide a estrazione totale con chiusura Blumotion. Portata massima per cassetto Kg 30. Elemento in marmo.

Elemento in marmo: cm 120x55 H13
Spazio utile interno: cm 116x51 H6
Spazio utile interno cassettoni
(A): cm 51x42 H14

EQUIPMENT

Nr. 2 large drawers that glide on fully extractable guides with Blumotion soft-close system. Maximum load per drawer is 30 Kg. Marble element.

Marble element: cm 120x55 H13
Internal dimension: cm 116x51 H6
Large drawers internal dimension
(A): cm 51x42 H14

CONTENITORE **LIVING** CON 5 CASSETTONI - **MOD. F**
LIVING SIDEBOARD WITH 5 LARGE DRAWERS - **MOD. F**

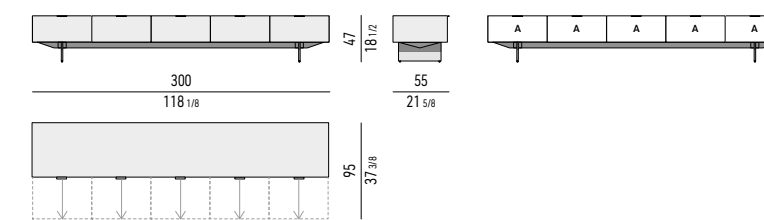

DOTAZIONE

Nr. 5 cassettoni che scorrono su guide a estrazione totale con chiusura Blumotion. Portata massima per cassetto Kg 30.

Spazio utile interno cassettoni
(A): cm 51x42 H14

EQUIPMENT

Nr. 5 large drawers that glide on fully extractable guides with Blumotion soft-close system. Maximum load per drawer is 30 Kg.

Large drawers internal dimension
(A): cm 51x42 H14

CONTENITORI DINING/LIVING | DINING/LIVING SIDEBARDS

ELEMENTO IN MARMO
MARBLE ELEMENT

MARMO
MARBLE



NEW 2025 FINISH

FONDO ELEMENTO IN MARMO
BOTTOM OF THE MARBLE ELEMENT

VETRO
GLASS

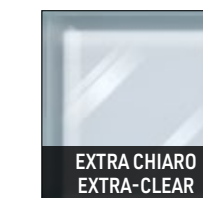

VASSOIO PORTAPOSATE
CUTLERY TRAY

CUOIO
SADDLE-HIDE

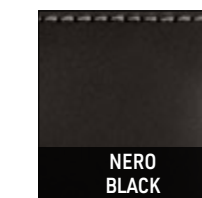

CONTENITORI NIGHT | NIGHT SIDEBARDS

TOP CASSETTO PORTAGIOIE
JEWELRY DRAWER TOP

VETRO CON RETE
GLASS WITH MESH

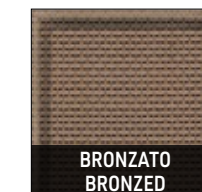

CASSETTO PORTAGIOIE
JEWELRY DRAWER

METALLO LUCIDO
POLISHED METAL

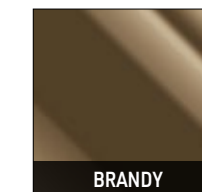

MANIGLIE E GAMBE
HANDLES AND LEGS

METALLO LUCIDO
POLISHED METAL

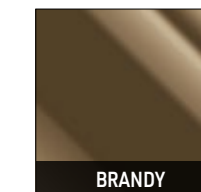

CONTENITORE **LIVING** CON 3 CASSETTONI ED ELEMENTO IN MARMO - **MOD. G**
LIVING SIDEBOARD WITH 3 LARGE DRAWERS AND MARBLE ELEMENT - **MOD. G**

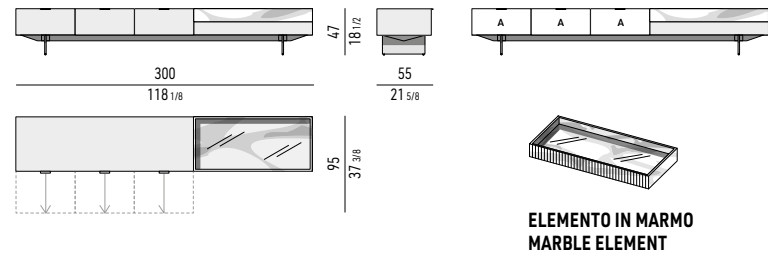

DOTAZIONE

Nr. 3 cassettoni che scorrono su guide a estrazione totale con chiusura Blumotion. Portata massima per cassetto Kg 30. Elemento in marmo.

Elemento in marmo: cm 120x55 H13
Spazio utile interno: cm 116x51 H6

Spazio utile interno cassettoni (A): cm 51x42 H14

EQUIPMENT

Nr. 3 large drawers that glide on fully extractable guides with Blumotion soft-close system. Maximum load per drawer is 30 Kg. Marble element.

Marble element: cm 120x55 H13
Internal dimension: cm 116x51 H6

Large drawers internal dimension (A): cm 51x42 H14

CONTENITORE **LIVING** CON 2 CASSETTONI, 4 CASSETTI ED ELEMENTO IN MARMO - **MOD. H**
LIVING SIDEBOARD WITH 2 LARGE DRAWERS, 4 SMALL DRAWERS AND MARBLE ELEMENT - **MOD. H**

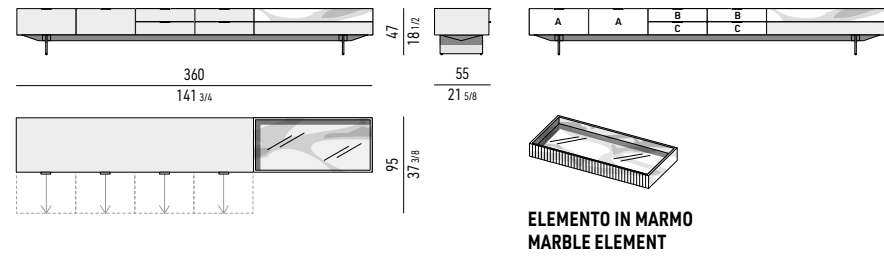

DOTAZIONE

Nr. 2 cassettoni (A) e 4 cassetti (B, C) che scorrono su guide a estrazione totale con chiusura Blumotion. Portata massima per cassetto Kg 30. Elemento in marmo.

Elemento in marmo: cm 120x55 H13
Spazio utile interno: cm 116x51 H6

Spazio utile interno cassetti (A): cm 51x42 H14
(B): cm 51x42 H6
(C): cm 51x42 H4

EQUIPMENT

Nr. 2 large drawers (A) and 4 small drawers (B, C) that glide on fully extractable guides with Blumotion soft-close system. Maximum load per drawer is 30 Kg. Marble element.

Marble element: cm 120x55 H13
Internal dimension: cm 116x51 H6

Drawers internal dimension (A): cm 51x42 H14
(B): cm 51x42 H6
(C): cm 51x42 H4

CONTENITORE **LIVING** CON 2 CASSETTONI, 6 CASSETTI ED ELEMENTO IN MARMO - **MOD. I**
LIVING SIDEBOARD WITH 2 LARGE DRAWERS, 6 SMALL DRAWERS AND MARBLE ELEMENT - **MOD. I**

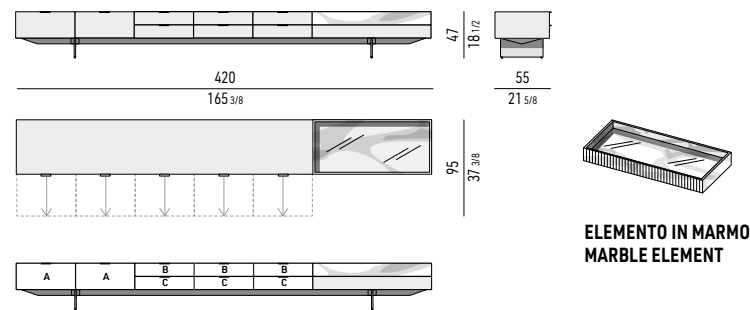

DOTAZIONE

Nr. 2 cassettoni (A) e 6 cassetti (B, C) che scorrono su guide a estrazione totale con chiusura Blumotion. Portata massima per cassetto Kg 30. Elemento in marmo.

Elemento in marmo: cm 120x55 H13
Spazio utile interno: cm 116x51 H6

Spazio utile interno cassetti (A): cm 51x42 H14
(B): cm 51x42 H6
(C): cm 51x42 H4

EQUIPMENT

Nr. 2 large drawers (A) and 6 small drawers (B, C) that glide on fully extractable guides with Blumotion soft-close system. Maximum load per drawer is 30 Kg. Marble element.

Marble element: cm 120x55 H13
Internal dimension: cm 116x51 H6

Drawers internal dimension (A): cm 51x42 H14
(B): cm 51x42 H6
(C): cm 51x42 H4

CONTENITORI "DINING" | "DINING" SIDEBOARDS

CONTENITORE **DINING** CON 3 CASSETTONI E 1 CASSETTO **CM H60 - MOD. J**
DINING SIDEBOARD WITH 3 LARGE DRAWERS AND 1 SMALL DRAWER **CM H60 - MOD. J**

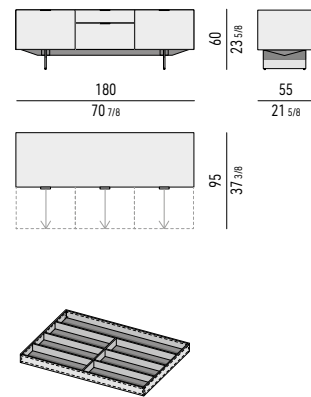

VASSOIO PORTAPOSATE | CUTLERY TRAY: CM 51X37 H3,5

Scomparto grande | big section: cm 49,5x8,5 H2,5
 Scomparto piccolo | small section cm: 24,5x8 H2,5

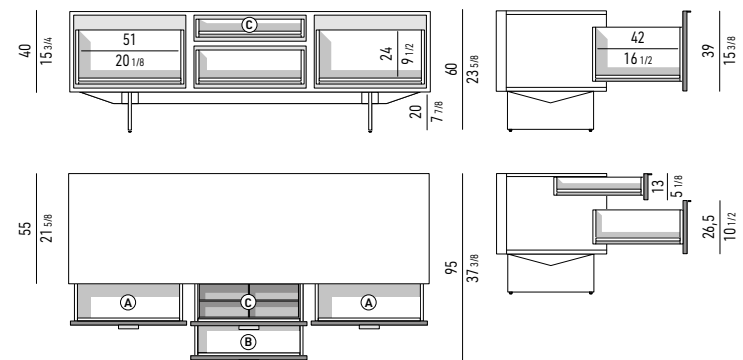

DOTAZIONE

Nr. 3 cassettoni e 1 cassetto che scorrono su guide a estrazione totale con chiusura Blumotion. Portata massima per cassetto Kg 30.

DOTAZIONE INTERNA
 Nr. 1 vassoio portaposate in cuoio color Nero dotato di divisori, riposto nel cassetto (C).

Spazio utile interno cassetti (A): cm 51x42 H24
(B): cm 51x42 H14

EQUIPMENT

Nr. 3 large drawers and 1 small drawer that glide on fully extractable guides with Blumotion soft-close system. Maximum load per drawer is 30 Kg.

INTERIOR EQUIPMENT
 Nr. 1 cutlery tray in Black colour saddle-hide, with dividers, located in the (C) drawer.

Drawers internal dimension (A): cm 51x42 H24
(B): cm 51x42 H14

CONTENITORE **DINING** CON 3 CASSETTONI E 1 CASSETTO **CM H70 - MOD. K**
DINING SIDEBOARD WITH 3 LARGE DRAWERS AND 1 SMALL DRAWER **CM H70 - MOD. K**

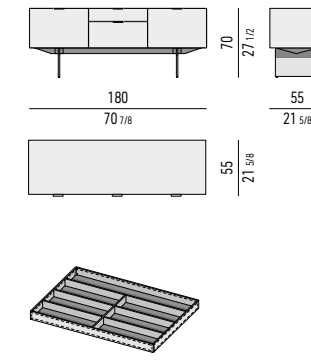

VASSOIO PORTAPOSATE | CUTLERY TRAY: CM 51X37 H3,5

Scomparto grande | big section: cm 49,5x8,5 H2,5
 Scomparto piccolo | small section cm: 24,5x8 H2,5

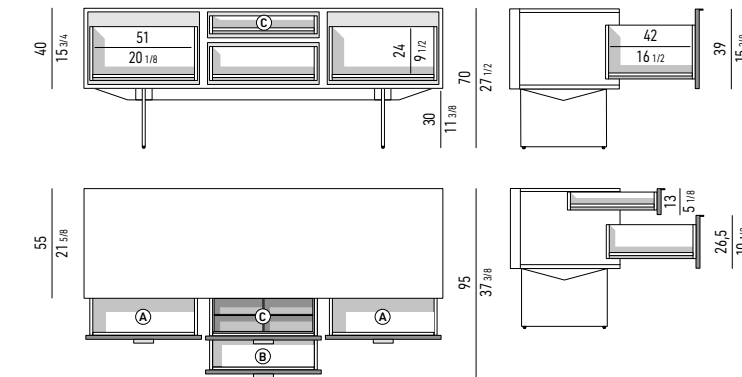

DOTAZIONE

Nr. 3 cassettoni e 1 cassetto che scorrono su guide a estrazione totale con chiusura Blumotion. Portata massima per cassetto Kg 30.

DOTAZIONE INTERNA

Nr. 1 vassoio portaposate in cuoio color Nero dotato di divisori, riposto nel cassetto (C).

Spazio utile interno cassetti (A): cm 51x42 H24
(B): cm 51x42 H14

EQUIPMENT

Nr. 3 large drawers and 1 small drawer that glide on fully extractable guides with Blumotion soft-close system. Maximum load per drawer is 30 Kg.

INTERIOR EQUIPMENT

Nr. 1 cutlery tray in Black colour saddle-hide, with dividers, located in the (C) drawer.

Drawers internal dimension (A): cm 51x42 H24
(B): cm 51x42 H14

CONTENITORE **DINING** CON 3 CASSETTONI E 3 CASSETTI **CM H74 - MOD. V**
DINING SIDEBOARD WITH 3 LARGE DRAWERS AND 3 SMALL DRAWERS **CM H74 - MOD. V**

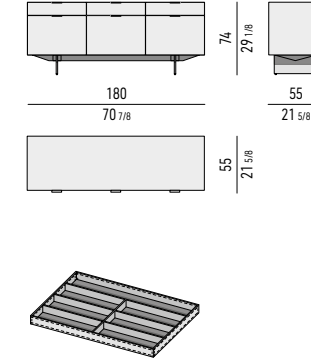

VASSOIO PORTAPOSATE | CUTLERY TRAY: CM 51X37 H3,5

Scomparto grande | big section: cm 49,5x8,5 H2,5
 Scomparto piccolo | small section cm: 24,5x8 H2,5

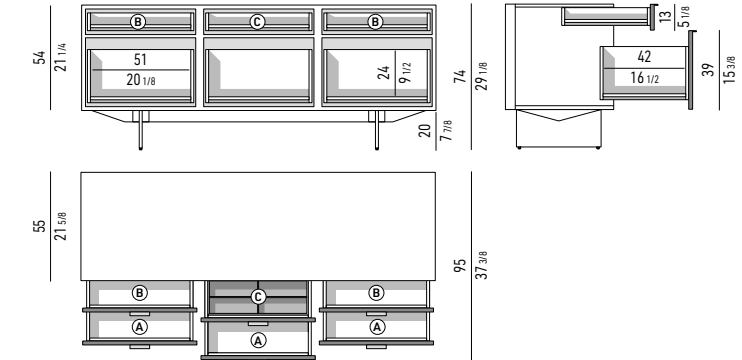

DOTAZIONE

Nr. 3 cassettoni e 3 cassetti che scorrono su guide a estrazione totale con chiusura Blumotion. Portata massima per cassetto Kg 30.

DOTAZIONE INTERNA

Nr. 1 vassoio portaposate in cuoio color Nero dotato di divisori, riposto nel cassetto (C).

Spazio utile interno cassetti (A): cm 51x42 H24
(B): cm 51x42 H6

EQUIPMENT

Nr. 3 large drawers and 3 small drawers that glide on fully extractable guides with Blumotion soft-close system. Maximum load per drawer is 30 Kg.

INTERIOR EQUIPMENT

Nr. 1 cutlery tray in Black colour saddle-hide, with dividers, located in the (C) drawer.

Drawers internal dimension (A): cm 51x42 H24
(B): cm 51x42 H6

CONTENITORE **DINING** CON 4 CASSETTONI **CM H60 - MOD. L**
DINING SIDEBOARD WITH 4 LARGE DRAWERS **CM H60 - MOD. L**

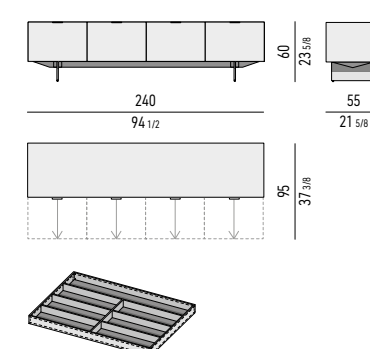

VASSOIO PORTAPOSATE | CUTLERY TRAY: CM 51X37 H3,5

Scomparto grande | big section: cm 49,5x8,5 H2,5
 Scomparto piccolo | small section cm: 24,5x8 H2,5

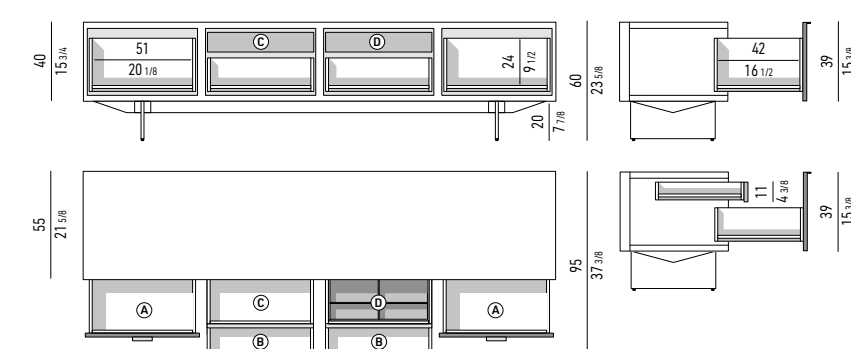

DOTAZIONE

Nr. 4 cassettoni che scorrono su guide a estrazione totale con chiusura Blumotion. Portata massima per cassetto Kg 30.

DOTAZIONE INTERNA

Nr. 2 cassetti (C, D) che scorrono su guide a estrazione totale con chiusura Blumotion. Portata massima per cassetto Kg 30.
 Nr. 1 vassoio portaposate in cuoio color Nero dotato di divisori, riposto nel cassetto (D).

Spazio utile interno cassetti (A): cm 51x42 H24
(B): cm 51x42 H14
(C): cm 51x42 H6

EQUIPMENT

Nr. 4 large drawers that glide on fully extractable guides with Blumotion soft-close system. Maximum load per drawer is 30 Kg.

INTERIOR EQUIPMENT

Nr. 2 small drawers (C, D) that glide on fully extractable guides with Blumotion soft-close system. Maximum load per drawer is 30 Kg.
 Nr. 1 cutlery tray in Black colour saddle-hide, with dividers, located in the (D) drawer.

Drawers internal dimension (A): cm 51x42 H24
(B): cm 51x42 H14
(C): cm 51x42 H6

CONTENITORE **DINING** CON 4 CASSETTONI E 4 CASSETTI **CM H74 - MOD. W**
DINING SIDEBOARD WITH 4 LARGE DRAWERS AND 4 SMALL DRAWERS **CM H74 - MOD. W**

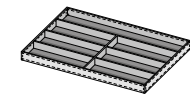
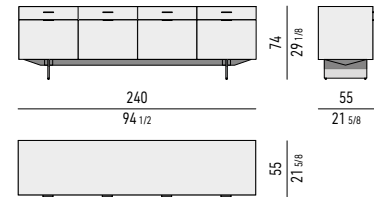

VASSOIO PORTAPOSATE | CUTLERY TRAY: CM 51X37 H3,5

Scoparto grande | big section: cm 49,5x8,5 H2,5
 Scoparto piccolo | small section cm: 24,5x8 H2,5

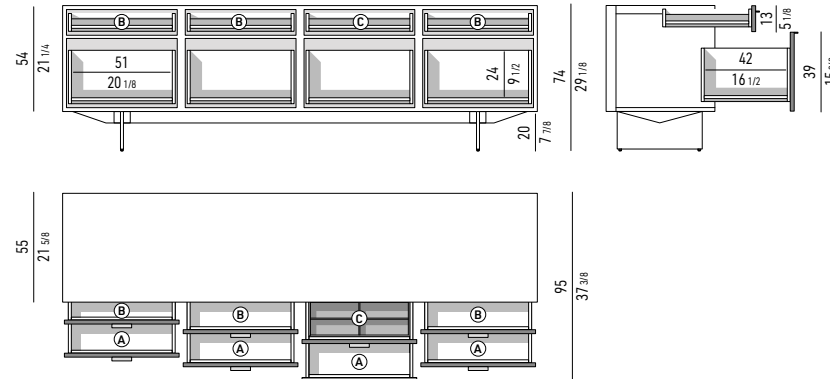

DOTAZIONE

Nr. 4 cassettoni e 4 cassetti che scorrono su guide a estrazione totale con chiusura Blumotion. Portata massima per cassetto Kg 30.

DOTAZIONE INTERNA

Nr. 1 vassoio portaposate in cuoio color Nero dotato di divisori, riposto nel cassetto **(C)**.

Spazio utile interno cassetti

(A): cm 51x42 H24
(B): cm 51x42 H6

EQUIPMENT

Nr. 4 large drawers and 4 small drawers that glide on fully extractable guides with Blumotion soft-close system. Maximum load per drawer is 30 Kg.

INTERIOR EQUIPMENT

Nr. 1 cutlery tray in Black colour saddle-hide, with dividers, located in the **(C)** drawer.

Drawers internal dimension

(A): cm 51x42 H24
(B): cm 51x42 H6

CONTENITORE **DINING** CON 4 CASSETTONI E 2 CASSETTI **CM H70 - MOD. N**
DINING SIDEBOARD WITH 4 LARGE DRAWERS AND 2 SMALL DRAWERS **CM H70 - MOD. N**

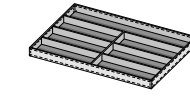
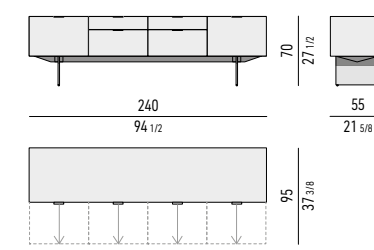

VASSOIO PORTAPOSATE | CUTLERY TRAY: CM 51X37 H3,5

Scoparto grande | big section: cm 49,5x8,5 H2,5
 Scoparto piccolo | small section cm: 24,5x8 H2,5

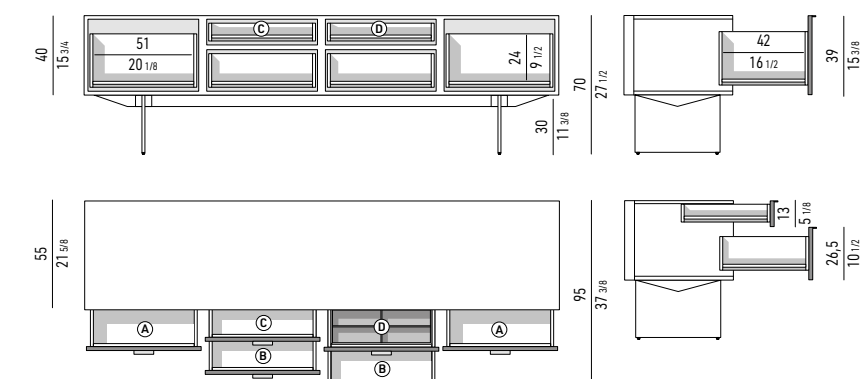

DOTAZIONE

Nr. 4 cassettoni e 2 cassetti che scorrono su guide a estrazione totale con chiusura Blumotion. Portata massima per cassetto Kg 30.

DOTAZIONE INTERNA

Nr. 1 vassoio portaposate in cuoio color Nero dotato di divisori, riposto nel cassetto **(D)**.

Spazio utile interno cassetti

(A): cm 51x42 H24
(B): cm 51x42 H14
(C): cm 51x42 H6

EQUIPMENT

Nr. 4 large drawers and 2 small drawers that glide on fully extractable guides with Blumotion soft-close system. Maximum load per drawer is 30 Kg.

INTERIOR EQUIPMENT

Nr. 1 cutlery tray in Black colour saddle-hide, with dividers, located in the **(D)** drawer.

Drawers internal dimension

(A): cm 51x42 H24
(B): cm 51x42 H14
(C): cm 51x42 H6

CONTENITORE **DINING** CON 4 CASSETTONI E 2 CASSETTI **CM H60 - MOD. M**
DINING SIDEBOARD WITH 4 LARGE DRAWERS AND 2 SMALL DRAWERS **CM H60 - MOD. M**

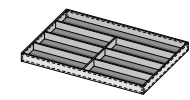
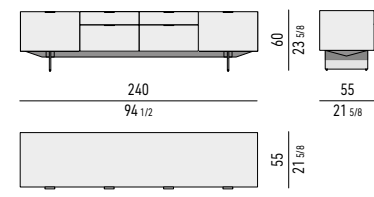

VASSOIO PORTAPOSATE | CUTLERY TRAY: CM 51X37 H3,5

Scoparto grande | big section: cm 49,5x8,5 H2,5
 Scoparto piccolo | small section cm: 24,5x8 H2,5

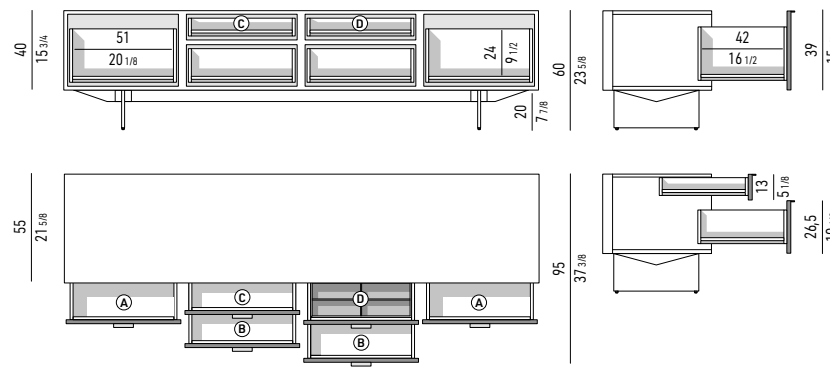

DOTAZIONE

Nr. 4 cassettoni e 2 cassetti che scorrono su guide a estrazione totale con chiusura Blumotion. Portata massima per cassetto Kg 30.

DOTAZIONE INTERNA

Nr. 1 vassoio portaposate in cuoio color Nero dotato di divisori, riposto nel cassetto **(D)**.

Spazio utile interno cassetti

(A): cm 51x42 H24
(B): cm 51x42 H14
(C): cm 51x42 H6

EQUIPMENT

Nr. 4 large drawers and 2 small drawers that glide on fully extractable guides with Blumotion soft-close system. Maximum load per drawer is 30 Kg.

INTERIOR EQUIPMENT

Nr. 1 cutlery tray in Black colour saddle-hide, with dividers, located in the **(D)** drawer.

Drawers internal dimension

(A): cm 51x42 H24
(B): cm 51x42 H14
(C): cm 51x42 H6

CONTENITORE **DINING** CON 4 CASSETTONI, 2 CASSETTI ED ELEMENTO IN MARMO **CM 60 - MOD. O**
DINING SIDEBOARD WITH 4 LARGE DRAWERS, 2 SMALL DRAWERS AND MARBLE ELEMENT **CM H60 - MOD. O**

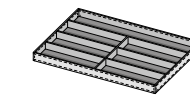
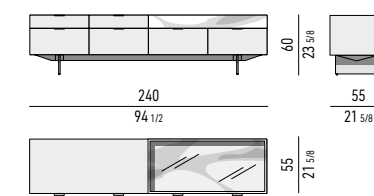

VASSOIO PORTAPOSATE | CUTLERY TRAY: CM 51X37 H3,5

Scoparto grande | big section: cm 49,5x8,5 H2,5
 Scoparto piccolo | small section cm: 24,5x8 H2,5

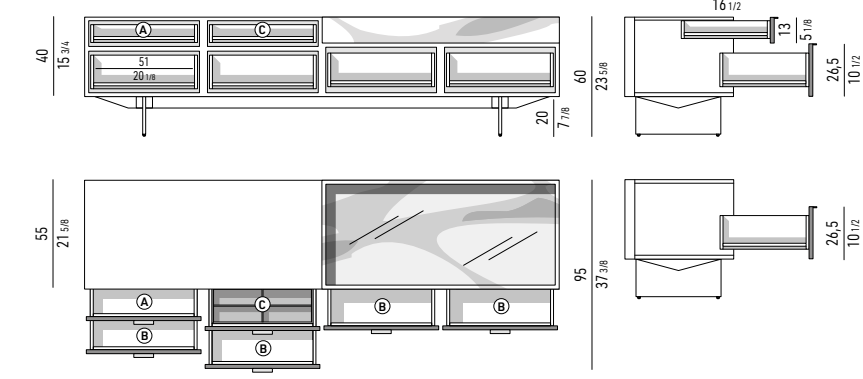

DOTAZIONE

Nr. 4 cassettoni **(B)** e 2 cassetti **(A, C)** che scorrono su guide a estrazione totale con chiusura Blumotion. Portata massima per cassetto Kg 30. Elemento in marmo.

DOTAZIONE INTERNA

Nr. 1 vassoio portaposate in cuoio color Nero dotato di divisori, riposto nel cassetto **(C)**.

Spazio utile interno cassetti

(A): cm 51x42 H6
(B): cm 51x42 H14

EQUIPMENT

Nr. 4 large drawers **(B)** and 2 small drawers **(A, C)** that glide on fully extractable guides with Blumotion soft-close system. Maximum load per drawer is 30 Kg. Marble element.

INTERIOR EQUIPMENT

Nr. 1 cutlery tray in Black colour saddle-hide, with dividers, located in the **(C)** drawer.

Drawers internal dimension

(A): cm 51x42 H6
(B): cm 51x42 H14

ELEMENTO IN MARMO | MARBLE ELEMENT: CM 120X55 H13
SPAZIO UTILE INTERNO | INTERNAL DIMENSION: CM 116X51 H6

CONTENITORE **DINING** CON 5 CASSETTONI E 3 CASSETTI **CM H60 - MOD. P**
DINING SIDEBOARD WITH 5 LARGE DRAWERS AND 3 SMALL DRAWERS **CM H60 - MOD. P**

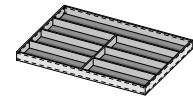
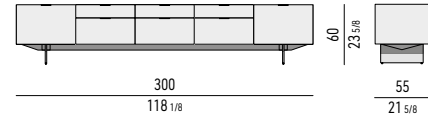

VASSOIO PORTAPOSATE | CUTLERY TRAY: CM 51X37 H3,5

Scoperto grande | big section: cm 49,5x8,5 H2,5
 Scoperto piccolo | small section cm: 24,5x8 H2,5

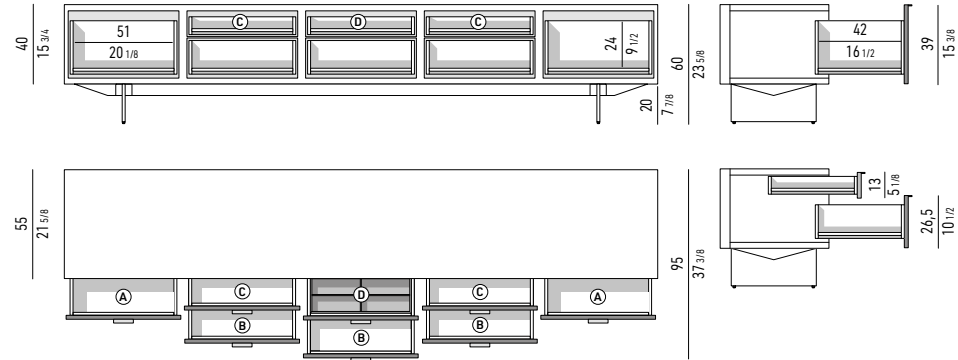

DOTAZIONE

Nr. 5 cassettoni e 3 cassetti che scorrono su guide a estrazione totale con chiusura Blumotion. Portata massima per cassetto Kg 30.

DOTAZIONE INTERNA

Nr. 1 vassoio portaposate in cuoio color Nero dotato di divisori, riposto nel cassetto (D).

Spazio utile interno cassetti

(A): cm 51x42 H24
 (B): cm 51x42 H14
 (C): cm 51x42 H6

EQUIPMENT

Nr. 5 large drawers and 3 small drawers that glide on fully extractable guides with Blumotion soft-close system. Maximum load per drawer is 30 Kg.

INTERIOR EQUIPMENT

Nr. 1 cutlery tray in Black colour saddle-hide, with dividers, located in the (D) drawer.

Drawers internal dimension

(A): cm 51x42 H24
 (B): cm 51x42 H14
 (C): cm 51x42 H6

CONTENITORE **DINING** CON 5 CASSETTONI E 3 CASSETTI **CM H70 - MOD. Q**
DINING SIDEBOARD WITH 5 LARGE DRAWERS AND 3 SMALL DRAWERS **CM H70 - MOD. Q**

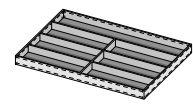
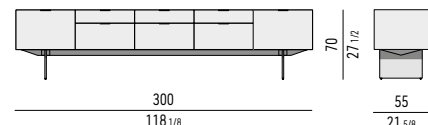

VASSOIO PORTAPOSATE | CUTLERY TRAY: CM 51X37 H3,5

Scoperto grande | big section: cm 49,5x8,5 H2,5
 Scoperto piccolo | small section cm: 24,5x8 H2,5

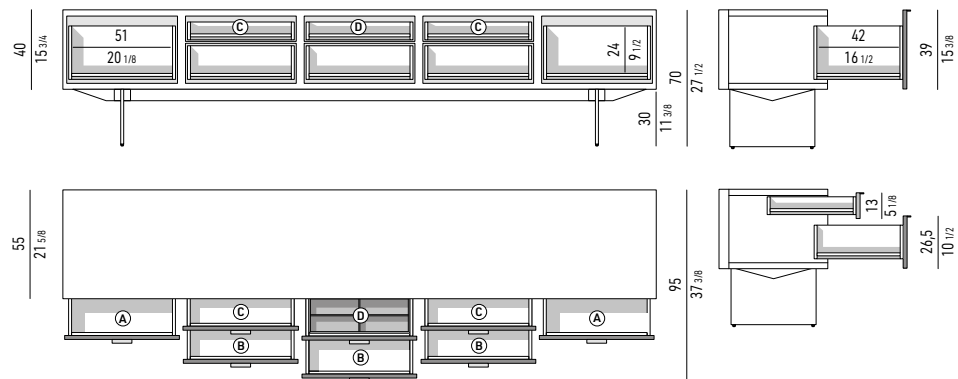

DOTAZIONE

Nr. 5 cassettoni e 3 cassetti che scorrono su guide a estrazione totale con chiusura Blumotion. Portata massima per cassetto Kg 30.

DOTAZIONE INTERNA

Nr. 1 vassoio portaposate in cuoio color Nero dotato di divisori, riposto nel cassetto (D).

Spazio utile interno cassetti

(A): cm 51x42 H24
 (B): cm 51x42 H14
 (C): cm 51x42 H6

EQUIPMENT

Nr. 5 large drawers and 3 small drawers that glide on fully extractable guides with Blumotion soft-close system. Maximum load per drawer is 30 Kg.

INTERIOR EQUIPMENT

Nr. 1 cutlery tray in Black colour saddle-hide, with dividers, located in the (D) drawer.

Drawers internal dimension

(A): cm 51x42 H24
 (B): cm 51x42 H14
 (C): cm 51x42 H6

CONTENITORE **DINING** CON 5 CASSETTONI E 5 CASSETTI **CM H74 - MOD. X**
DINING SIDEBOARD WITH 5 LARGE DRAWERS AND 5 SMALL DRAWERS **CM H74 - MOD. X**

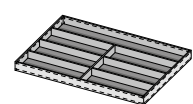
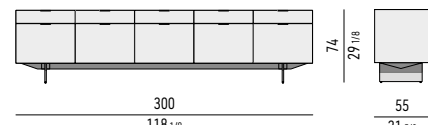

VASSOIO PORTAPOSATE | CUTLERY TRAY: CM 51X37 H3,5

Scoperto grande | big section: cm 49,5x8,5 H2,5
 Scoperto piccolo | small section cm: 24,5x8 H2,5

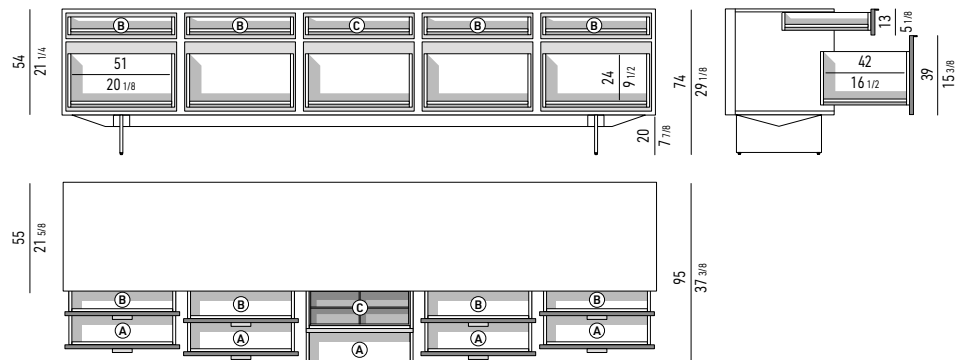

DOTAZIONE

Nr. 5 cassettoni e 5 cassetti che scorrono su guide a estrazione totale con chiusura Blumotion. Portata massima per cassetto Kg 30.

DOTAZIONE INTERNA

Nr. 1 vassoio portaposate in cuoio color Nero dotato di divisori, riposto nel cassetto (C).

Spazio utile interno cassetti

(A): cm 51x42 H24
 (B): cm 51x42 H6

EQUIPMENT

Nr. 5 large drawers and 5 small drawers that glide on fully extractable guides with Blumotion soft-close system. Maximum load per drawer is 30 Kg.

INTERIOR EQUIPMENT

Nr. 1 cutlery tray in Black colour saddle-hide, with dividers, located in the (C) drawer.

Drawers internal dimension

(A): cm 51x42 H24
 (B): cm 51x42 H6

CONTENITORI "NIGHT" | "NIGHT" SIDEBARDS

CONTENITORE **NIGHT** CON 1 CASSETTONE E 4 CASSETTI **CM H60 - MOD. R**
NIGHT SIDEBOARD WITH 1 LARGE DRAWER AND 4 SMALL DRAWERS **CM H60 - MOD. R**

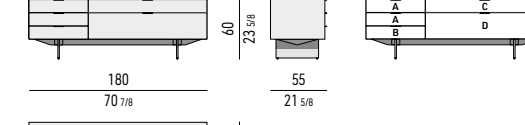

CONTENITORE **NIGHT** CON 1 CASSETTONE E 4 CASSETTI **CM H70 - MOD. S**
NIGHT SIDEBOARD WITH 1 LARGE DRAWER AND 4 SMALL DRAWERS **CM H70 - MOD. S**

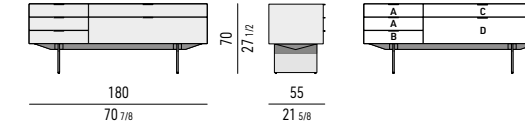

CONTENITORE **NIGHT** CON 1 CASSETTONE, 3 CASSETTI E CASSETTO PORTAGIOIE **CM H60 - MOD. T**
NIGHT SIDEBOARD WITH 1 LARGE DRAWER, 3 SMALL DRAWERS AND JEWELRY DRAWER **CM H60 - MOD. T**

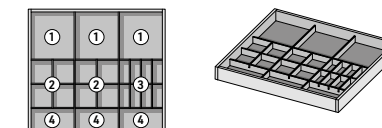
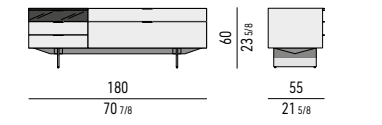

CASSETTO PORTAGIOIE | JEWELRY DRAWER

Scoperto | section 1: cm 20x18 H3
 Scoperto | section 2: cm 9x10 H3
 Scoperto | section 3: cm 4x10 H3
 Scoperto | section 4: cm 18x10 H3

CONTENITORE **NIGHT** CON 1 CASSETTONE, 3 CASSETTI E CASSETTO PORTAGIOIE **CM H70 - MOD. U**
NIGHT SIDEBOARD WITH 1 LARGE DRAWER, 3 SMALL DRAWERS AND JEWELRY DRAWER **CM H70 - MOD. U**

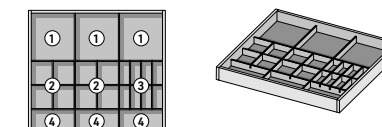
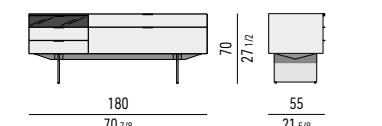

CASSETTO PORTAGIOIE | JEWELRY DRAWER

Scoperto | section 1: cm 20x18 H3
 Scoperto | section 2: cm 9x10 H3
 Scoperto | section 3: cm 4x10 H3
 Scoperto | section 4: cm 18x10 H3

DOTAZIONE

Nr. 1 cassettone (D) e 4 cassetti (A, B, C) che scorrono su guide a estrazione totale con chiusura Blumotion. Portata massima per cassetto Kg 30.

Spazio utile interno cassetti

(A): cm 51x42 H6
 (B): cm 51x42 H4
 (C): cm 111x42 H6
 (D): cm 111x42 H14

EQUIPMENT

Nr. 1 large drawer (D) and 4 small drawers (A, B, C) that glide on fully extractable guides with Blumotion soft-close system. Maximum load per drawer is 30 Kg.

Drawers internal dimension

(A): cm 51x42 H6
 (B): cm 51x42 H4
 (C): cm 111x42 H6
 (D): cm 111x42 H14

DOTAZIONE

Nr. 1 cassettone (D) e 4 cassetti (A, B, C) che scorrono su guide a estrazione totale con chiusura Blumotion. Portata massima per cassetto Kg 30.

Spazio utile interno cassetti

(A): cm 51x42 H6
 (B): cm 51x42 H4
 (C): cm 111x42 H6
 (D): cm 111x42 H14

EQUIPMENT

Nr. 1 large drawer (D) and 4 small drawers (A, B, C) that glide on fully extractable guides with Blumotion soft-close system. Maximum load per drawer is 30 Kg.

Drawers internal dimension

(A): cm 51x42 H6
 (B): cm 51x42 H4
 (C): cm 111x42 H6
 (D): cm 111x42 H14

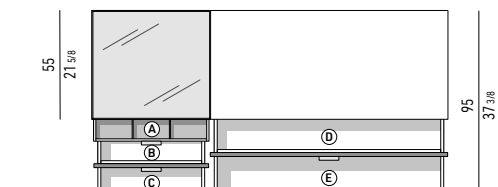
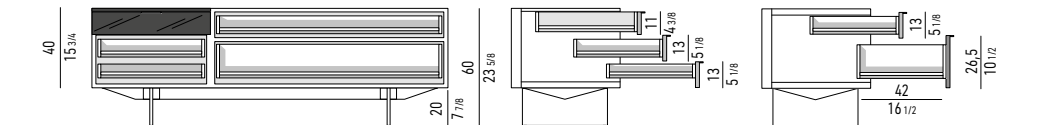

DOTAZIONE

Nr. 1 cassettone (E) e 3 cassetti (B, C, D) che scorrono su guide a estrazione totale con chiusura Blumotion. Portata massima per cassetto Kg 30.

Nr. 1 cassetto portagioie (A) che scorre su guide a estrazione totale. Portata massima per cassetto Kg 30.

Spazio utile interno cassetti

(B): cm 51x42 H6
 (C): cm 51x42 H4
 (D): cm 111x42 H6
 (E): cm 111x42 H14

EQUIPMENT

Nr. 1 large drawer (E) and 3 small drawers (B, C, D) that glide on fully extractable guides with Blumotion soft-close system. Maximum load per drawer is 30 Kg.

Nr. 1 jewelry drawer (A) that glide on fully extractable guides. Maximum load per drawer is 30 Kg.

Drawers internal dimension

(B): cm 51x42 H6
 (C): cm 51x42 H4
 (D): cm 111x42 H6
 (E): cm 111x42 H14

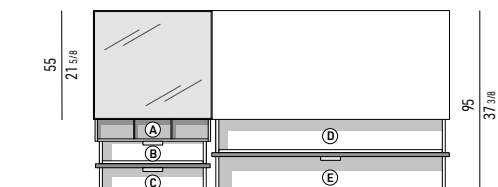
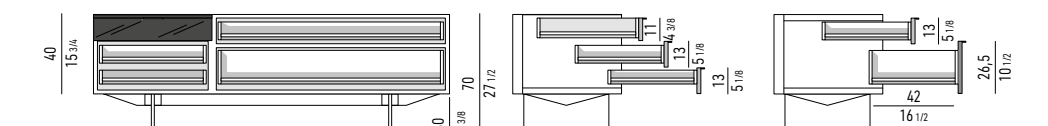

DOTAZIONE

Nr. 1 cassettone (E) e 3 cassetti (B, C, D) che scorrono su guide a estrazione totale con chiusura Blumotion. Portata massima per cassetto Kg 30.

Nr. 1 cassetto portagioie (A) che scorre su guide a estrazione totale. Portata massima per cassetto Kg 30.

Spazio utile interno cassetti

(B): cm 51x42 H6
 (C): cm 51x42 H4
 (D): cm 111x42 H6
 (E): cm 111x42 H14

EQUIPMENT

Nr. 1 large drawer (E) and 3 small drawers (B, C, D) that glide on fully extractable guides with Blumotion soft-close system. Maximum load per drawer is 30 Kg.

Nr. 1 jewelry drawer (A) that glide on fully extractable guides. Maximum load per drawer is 30 Kg.

Drawers internal dimension

(B): cm 51x42 H6
 (C): cm 51x42 H4
 (D): cm 111x42 H6
 (E): cm 111x42 H14



MODULO 60 | MODULE 60

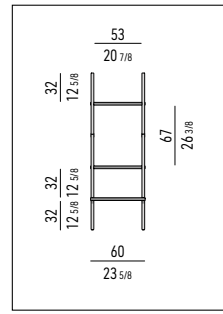

LIBRERIA CM 60X46 H103
BOOKCASE CM 60X46 H103

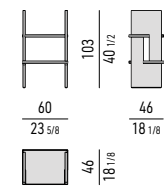

LIBRERIA CM 60X46 H173 - MOD. A
BOOKCASE CM 60X46 H173 - MOD. A

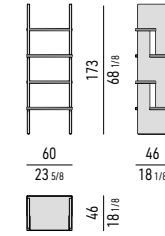

LIBRERIA CM 60X46 H173 - MOD. B
BOOKCASE CM 60X46 H173 - MOD. B

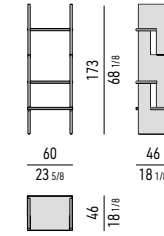

LIBRERIA CM 60X46 H208 - MOD. A
BOOKCASE CM 60X46 H208 - MOD. A

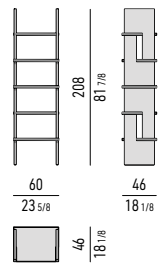

LIBRERIA CM 60X46 H208 - MOD. B
BOOKCASE CM 60X46 H208 - MOD. B

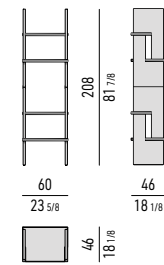

LIBRERIA CM 60X46 H243 - MOD. A
BOOKCASE CM 60X46 H243 - MOD. A

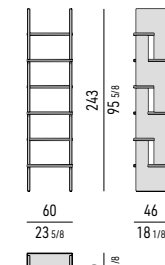

LIBRERIA CM 60X46 H243 - MOD. B
BOOKCASE CM 60X46 H243 - MOD. B

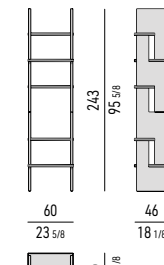

MODULO 100 | MODULE 100

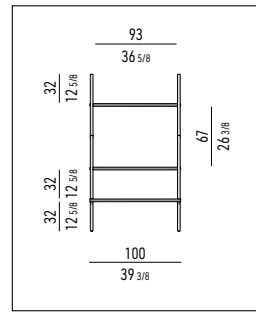

LIBRERIA CM 100X46 H103
BOOKCASE CM 100X46 H103

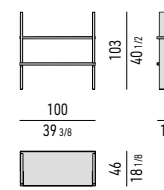

LIBRERIA CM 100X46 H173 - MOD. A
BOOKCASE CM 100X46 H173 - MOD. A

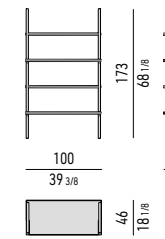

LIBRERIA CM 100X46 H173 - MOD. B
BOOKCASE CM 100X46 H173 - MOD. B

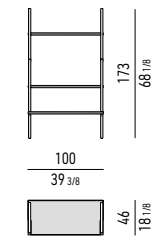

LIBRERIA CM 100X46 H208 - MOD. A
BOOKCASE CM 100X46 H208 - MOD. A

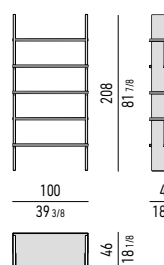

LIBRERIA CM 100X46 H208 - MOD. B
BOOKCASE CM 100X46 H208 - MOD. B

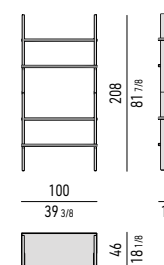

LIBRERIA CM 100X46 H243 - MOD. A
BOOKCASE CM 100X46 H243 - MOD. A

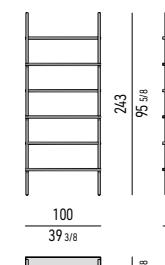

LIBRERIA CM 100X46 H243 - MOD. B
BOOKCASE CM 100X46 H243 - MOD. B

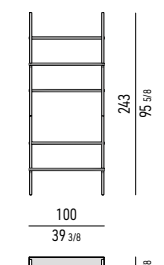

COMBINAZIONI FINITURE | FINISHES' COMBINATIONS

FIANCHI SIDES

RIPIANI SHELVES

METALLO SATINATO PROFONDO
DEEP SATIN METAL

NOCE CANALETTO
CANALETTO WALNUT

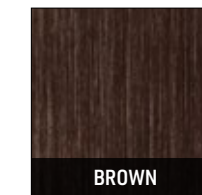

BROWN

NEW 2025 FINISH

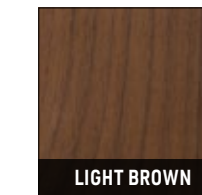

LIGHT BROWN

NEW 2025 FINISH

FIANCHI SIDES

RIPIANI SHELVES

ALLUMINIO LUCIDO
POLISHED ALUMINIUM

FRASSINO
ASH

LACCATO LUCIDO
GLOSSY LACQUERED



CAPPUCCINO

NEW 2025 FINISH

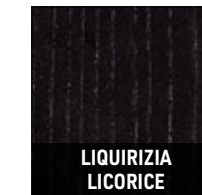

LIQUIRIZIA
LICORICE

NEW 2025 FINISH



CAPPUCCINO

NEW 2025 FINISH

FIANCHI SIDES

RIPIANI SHELVES

ALLUMINIO LUCIDO
POLISHED ALUMINIUM

NOCE CANALETTO
CANALETTO WALNUT

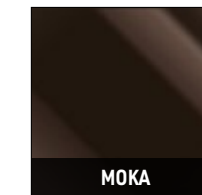

MOKA

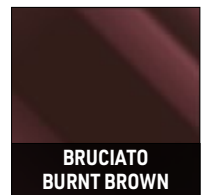

BRUCIATO
BURNT BROWN

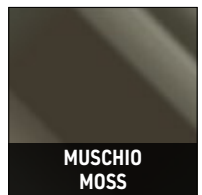

MUSCHIO
MOSS

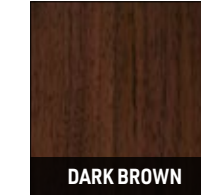

DARK BROWN

FIANCHI SIDES

RIPIANI SHELVES

ALLUMINIO LUCIDO
POLISHED ALUMINIUM

LACCATO LUCIDO
GLOSSY LACQUERED

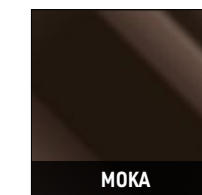

MOKA

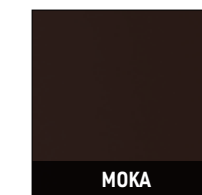

BRUCIATO
BURNT BROWN

FIANCHI SIDES

RIPIANI SHELVES

ALLUMINIO LUCIDO
POLISHED ALUMINIUM

LACCATO LUCIDO
GLOSSY LACQUERED

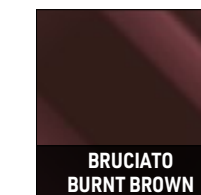

BRUCIATO
BURNT BROWN



BRUCIATO
BURNT BROWN

FIANCHI SIDES

RIPIANI SHELVES

ALLUMINIO LUCIDO
POLISHED ALUMINIUM

LACCATO LUCIDO
GLOSSY LACQUERED

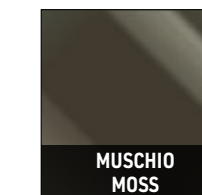

MUSCHIO
MOSS

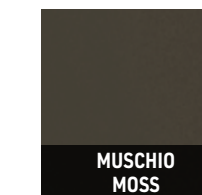

MUSCHIO
MOSS

LIBRA BED

GIAMPIERO TAGLIAFERRI DESIGN



LETTO CM **232X246** - 212X246 - 192X246
BED CM **232X246** - 212X246 - 192X246

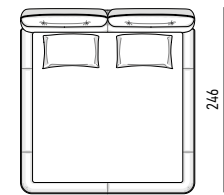
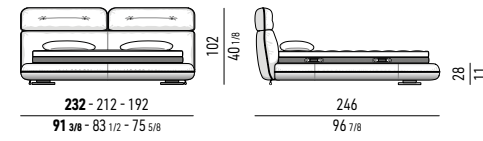

MATERASSO: CM **200X200** - 180X200 - 160X200
MATTRESS: CM **78 3/4 X 78 3/4** - 70 7/8 X 78 3/4 - 63 X 78 3/4

LETTO **KING SIZE** - QUEEN SIZE CM **225X249** - 185X249
BED **KING SIZE** - QUEEN SIZE CM **225X249** - 185X249

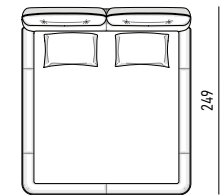
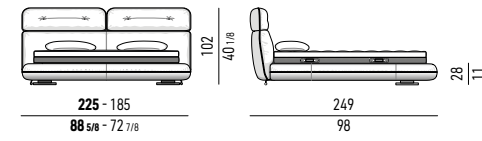

MATERASSO: CM **193X203** - 153X203
MATTRESS: CM **76 X 79 7/8** - 60 1/4 X 79 7/8

PANCHE | BENCHES

PANCA CM **212X52** - 192X52 - 172X52 **H37**
BENCH CM **212X52** - 192X52 - 172X52 **H37**

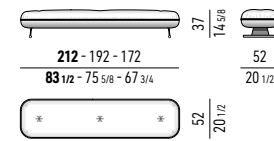

PANCA **KING SIZE** - QUEEN SIZE CM **205X52** - 165X52 **H37**
BENCH **KING SIZE** - QUEEN SIZE CM **205X52** - 165X52 **H37**

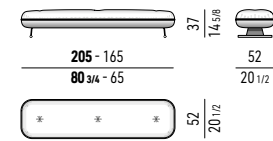

OPZIONI SOMMIER | SOMMIER OPTIONS

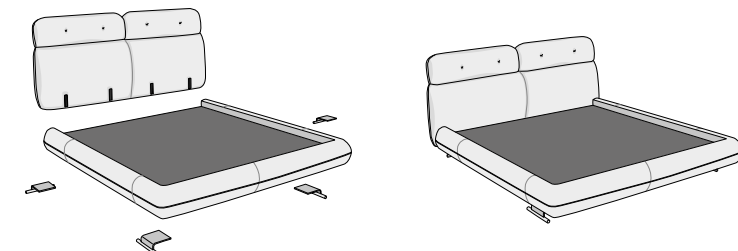

SOMMIER INTERO
LA TESTATA VIENE AGGANCIATA ATTRAVERSO UN SISTEMA DI INNESTO E SGANCIO RAPIDO
ONE-PIECE SOMMIER
THE HEADBOARD IS FASTENED THROUGH A QUICK SET AND RELEASE COUPLING SYSTEM.

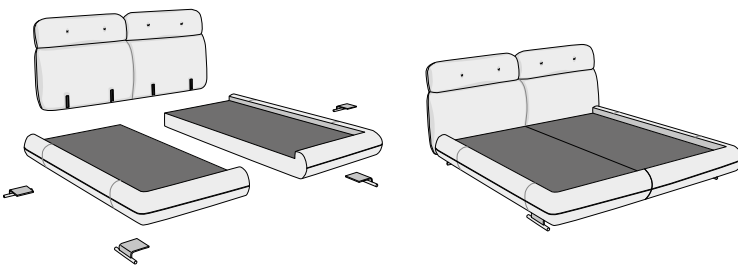

SOMMIER DIVISO
VERSIONE CON SOMMIER DIVISO IN DUE ELEMENTI, AL FINE DI FACILITARE LA CONSEGNA. I DUE ELEMENTI SI CONGIUNGONO TRA LORO A MEZZO DI UN'APPOSITA CREMAGLIERA. LA TESTATA VIENE AGGANCIATA ATTRAVERSO UN SISTEMA DI INNESTO E SGANCIO RAPIDO.
TWO-PIECES SOMMIER
TO FACILITATE DELIVERY, A VERSION WITH THE SOMMIER IN TWO PIECES IS NOW AVAILABLE. THE TWO PIECES ARE JOINED BY MEANS OF A SPECIAL CONNECTING DEVICE. THE HEADBOARD IS FASTENED THROUGH A QUICK SET AND RELEASE COUPLING SYSTEM.

BASI BASES

METALLO METAL

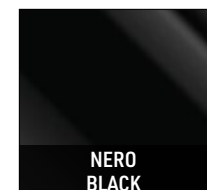

BARRE CILINDRICHE CYLINDRICAL BARS

METALLO LUCIDO POLISHED METAL



BASI E BARRE CILINDRICHE BASES AND CYLINDRICAL BARS

METALLO LUCIDO POLISHED METAL

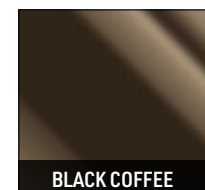

ALTEZZA BASE MATERASSO | MATTRESS BASE HEIGHT

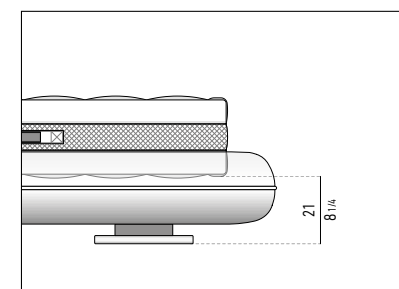

LIBRA BEDSPREAD / LIBRA THROW

MINOTTI STUDIO DESIGN

COPRILETTO | BEDSPREAD

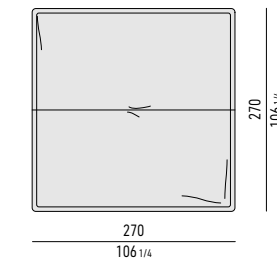

PLAID | THROWS

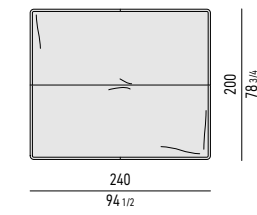
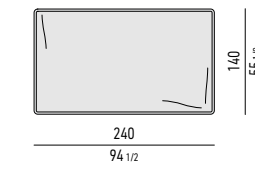

ZEALAND

MINOTTI STUDIO

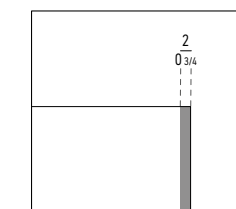
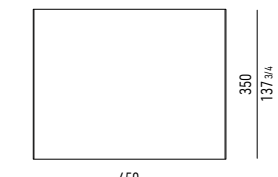
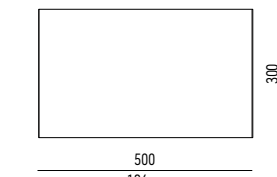
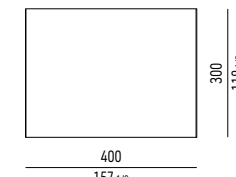
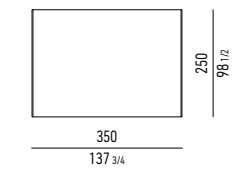

LATO CORTO: BORDO IN NUANCE CROMATICA (2 CM)
SHORT SIDE: BORDER MADE IN A CHROMATIC NUANCE (2 CM)

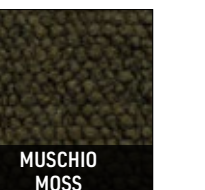
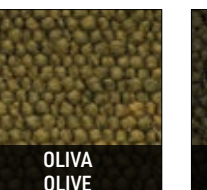
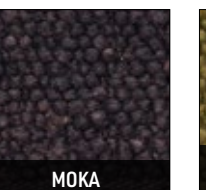
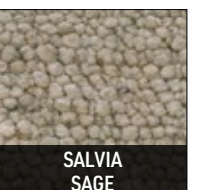
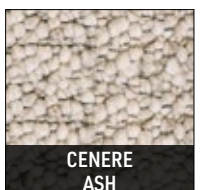
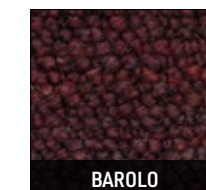

FAIRWAY MINOTTI STUDIO

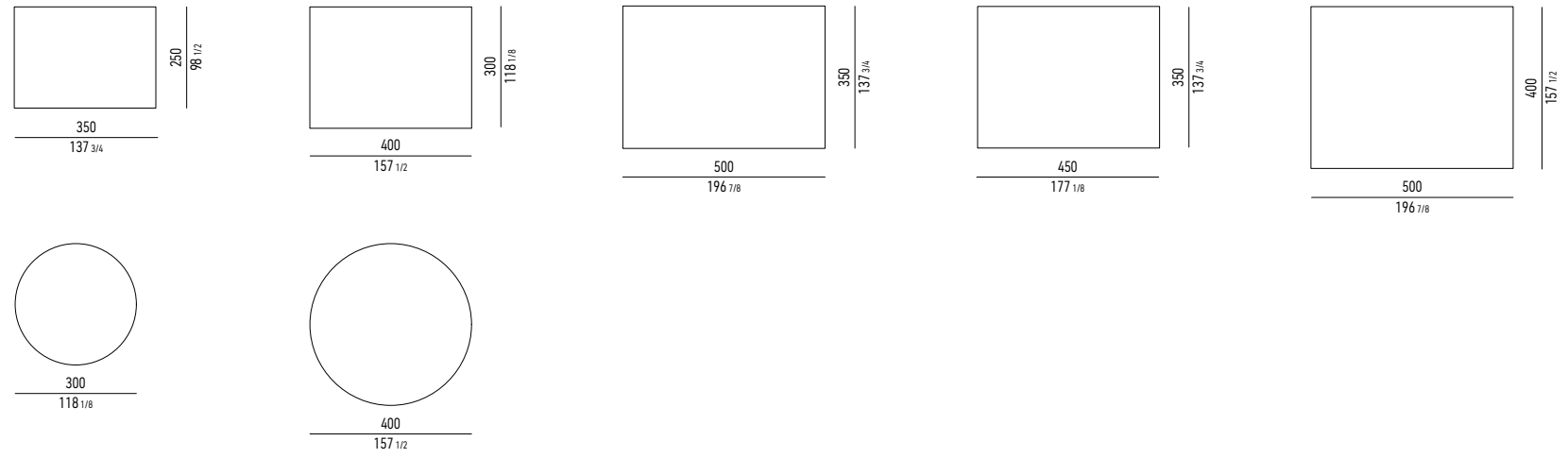

ALPS (UPDATE) MINOTTI STUDIO

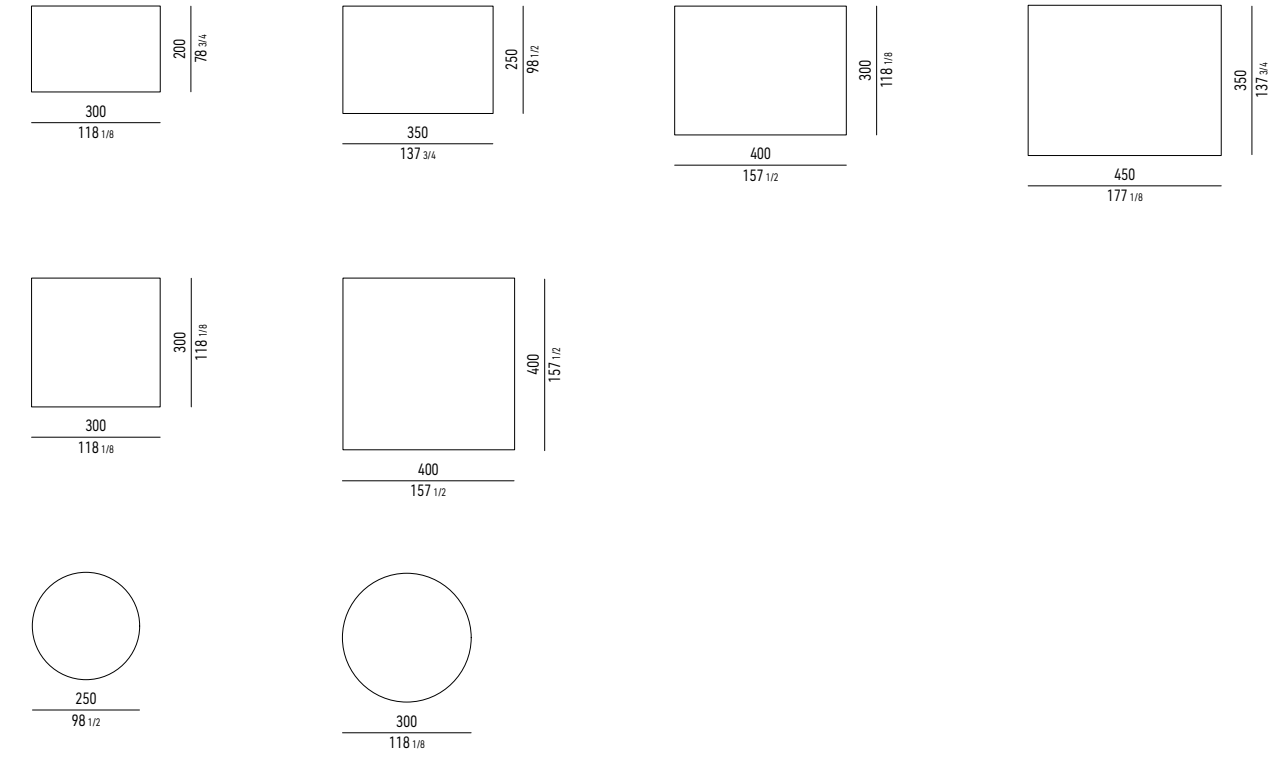

PERSONALIZZATO SUL RETRO CON UN ELEGANTE TESSUTO JACQUARD CON LOGO MINOTTI, GARANTISCE UNA FUNZIONE ANTISCIVOLO GRAZIE A UN TESSUTO TECNICO DI COTONE STAMPATO CON MICRO PARTICELLE DI SILICONE.

PERSONALISED ON THE BACK WITH AN ELEGANT JACQUARD FABRIC FEATURING THE MINOTTI LOGO, IT GUARANTEES ANTI-SLIP PROPERTIES, THANKS TO A TECHNICAL PRINTED COTTON FABRIC WITH MICRO-PARTICLES OF SILICONE.

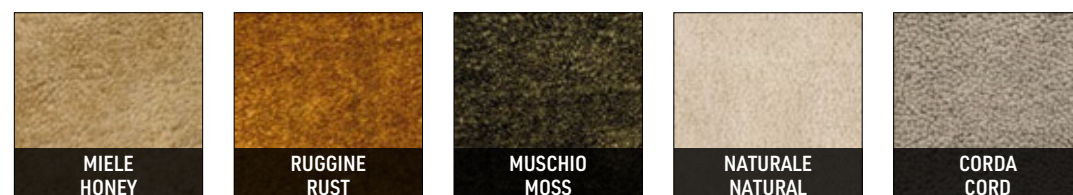

NEW 2025 COLOUR

SAKI OUTDOOR / SAKI CORD OUTDOOR NENDO DESIGN



PANORAMICA | OVERVIEW

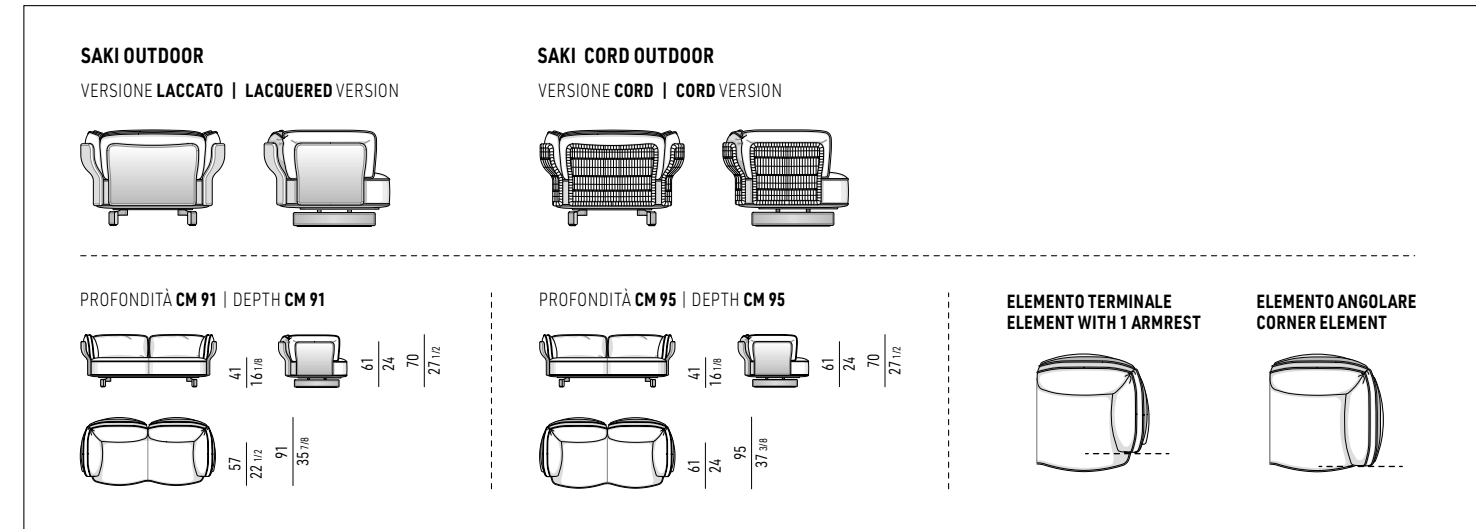

PROFONDITÀ CM 91 | DEPTH CM 91

POLTRONE | ARMCHAIRS

POLTRONA CM 104X91 H69
ARMCHAIR CM 104X91 H69

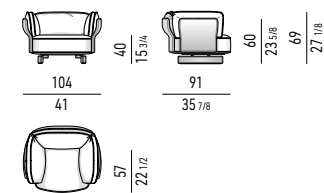

POLTRONA CON BRACCIOLLO CM 92X91 H69 - SX/DX
ARMCHAIR WITH ARMREST CM 92X91 H69 - SX/DX

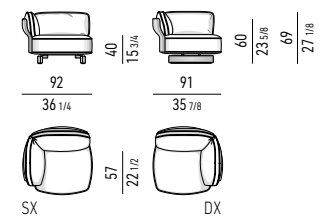

POLTRONA SENZA BRACCIOLI CM 80X91 H69
ARMCHAIR WITHOUT ARMRESTS CM 80X91 H69

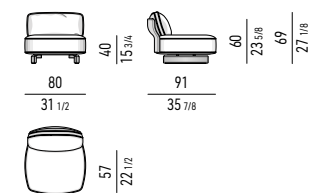

POGGIAPIEDI / POUF CM 80X78 H40
FOOTSTOOL / OTTOMAN CM 80X78 H40

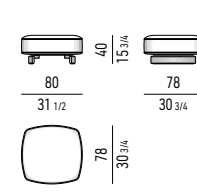

DIVANI | SOFAS

DIVANO CM 254X91 - 180X91
SOFA CM 254X91 - 180X91

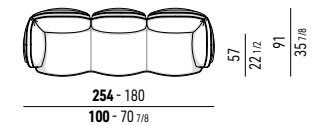

ELEMENTI CENTRALI | CENTRAL ELEMENTS

ELEMENTO CENTRALE CM 230X91 - 156X91
CENTRAL ELEMENT CM 230X91 - 156X91

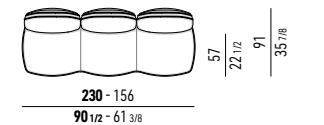

PROFONDITÀ CM 95 | DEPTH CM 95

DIVANI | SOFAS

DIVANO CM 330X95 - 254X95 - 180X95
SOFA CM 330X95 - 254X95 - 180X95

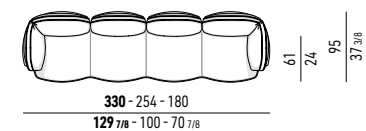

DIVANI ANGOLARI | CORNER SOFAS

DIVANO ANGOLARE CM 330X95 - 254X95 - 180X95 - SX/DX
CORNER SOFA CM 330X95 - 254X95 - 180X95 - SX/DX

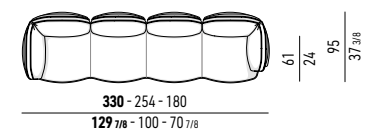

ELEMENTI TERMINALI | ELEMENTS WITH 1 ARMREST

ELEMENTO TERMINALE CM 316X95 - 242X95 - 168X95 - SX/DX
ELEMENT WITH 1 ARMREST CM 316X95 - 242X95 - 168X95 - SX/DX

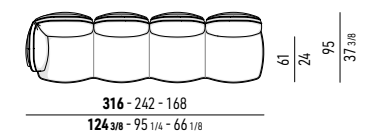

ELEMENTI ANGOLARI | CORNER ELEMENTS

ELEMENTO ANGOLARE CM 316X95 - 242X95 - 168X95 - SX/DX
CORNER ELEMENT CM 316X95 - 242X95 - 168X95 - SX/DX

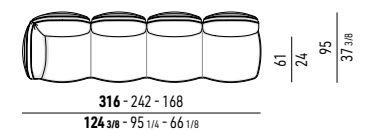

ELEMENTI CENTRALI | CENTRAL ELEMENTS

ELEMENTO CENTRALE CM 304X95 - 230X95 - 156X95
CENTRAL ELEMENT CM 304X95 - 230X95 - 156X95

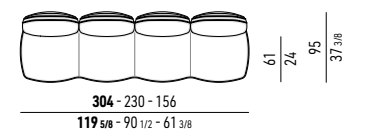

PANCHE | BENCHES

PANCA CM 304X82 - 230X82 - 156X82
BENCH CM 304X82 - 230X82 - 156X82



ELEMENTI ISOLA | ISLAND ELEMENTS

ISOLA CM 168X168 - SX/DX - MOD. A
ISLAND CM 168X168 - SX/DX - MOD. A

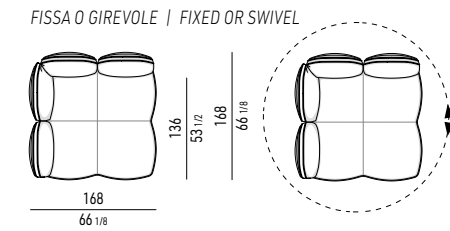

ISOLA CM 168X168 - SX/DX - MOD. B
ISLAND CM 168X168 - SX/DX - MOD. B

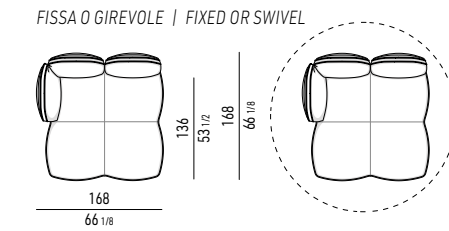

ISOLA CM 156X168 - SX/DX - MOD. C
ISLAND CM 156X168 - SX/DX - MOD. C

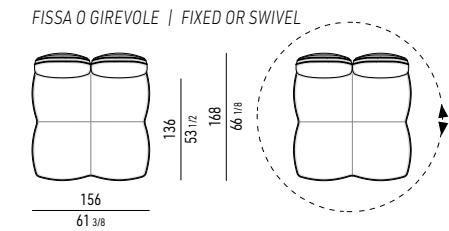

ISOLA CM 168X168 - SX/DX - MOD. D
ISLAND CM 168X168 - SX/DX - MOD. D

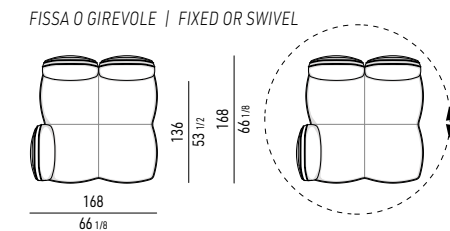

ISOLA CM 168X168 - SX/DX - MOD. E
ISLAND CM 168X168 - SX/DX - MOD. E

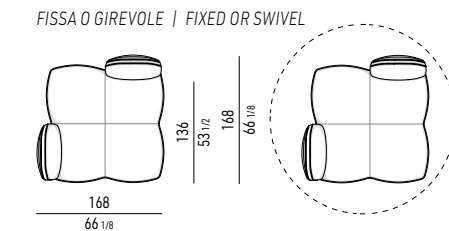

ISOLA CM 156X168 - SX/DX - MOD. F
ISLAND CM 156X168 - SX/DX - MOD. F

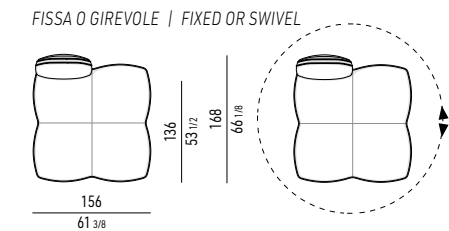

ISOLA CM 156X156 H41 - SX/DX - MOD. G
ISLAND CM 156X156 H41 - SX/DX - MOD. G

FISSA | FIXED

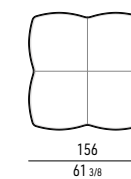

ISOLA CM 156X156 H41 - MOD. G
ISLAND CM 156X156 H41 - MOD. G

GIREVOLE | SWIVEL

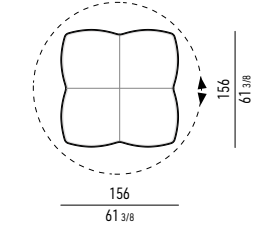

POSIZIONE BASI ELEMENTI "ISOLA"
BASES POSITION "ISLAND" ELEMENTS

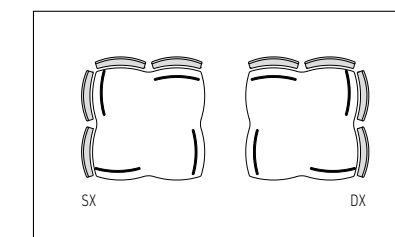

ELEMENTI "ISOLA"
"ISLAND" ELEMENTS

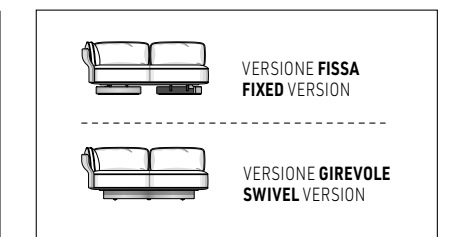

CUSCINO OPTIONAL | OPTIONAL CUSHION

CUSCINO OPTIONAL CM 50X50
OPTIONAL CUSHION CM 50X50

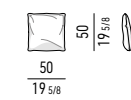

OPTIONAL RAIN COVER



PANNELLI DI SOSTEGNO
SUPPORT PANELS

FIBRA INTRECCIATA
BRIDED FIBRE

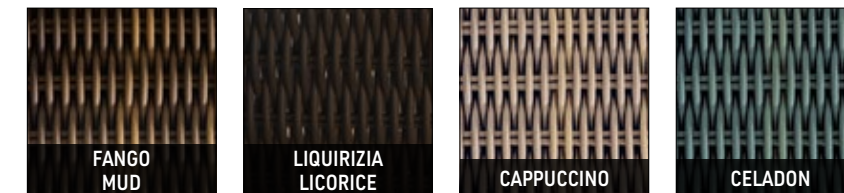

PANNELLI DI SOSTEGNO
SUPPORT PANELS

LACCATO LUCIDO
GLOSSY LACQUERED



PIEDI E BASE GIREVOLE "ELEMENTI ISOLA"
FEET AND "ISLAND ELEMENTS" SWIVEL BASE

ALLUMINIO LUCIDO
POLISHED ALUMINIUM

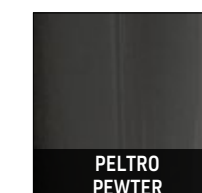

BÉZIER CORD OUTDOOR

MARCIO KOGAN / STUDIO MK27 DESIGN



PANORAMICA | OVERVIEW

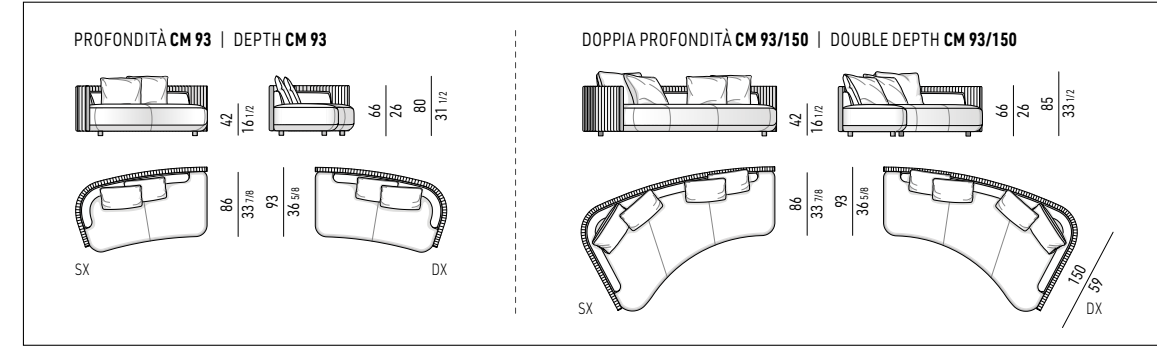

CUSCINO POGGIARENI | LUMBAR CUSHION

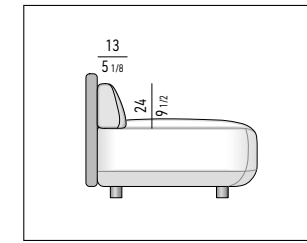

POLTRONA / PAOLINA | ARMCHAIR / PAOLINA

POLTRONA / PAOLINA CM 121X163 - SX/DX
ARMCHAIR / PAOLINA CM 121X163 - SX/DX

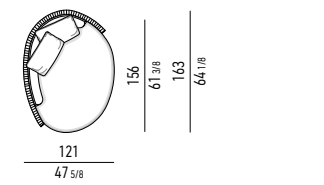

DIVANO | SOFA

DIVANO CM 270X154 - SX/DX - DOPPIA PROFONDITÀ
SOFA CM 270X154 - SX/DX - DOUBLE DEPTH

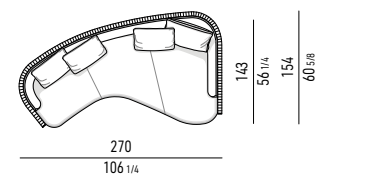

ELEMENTI TERMINALI | ELEMENTS WITH 1 ARMREST

ELEMENTO TERMINALE CM 175 - 124 - SX/DX
ELEMENT WITH 1 ARMREST CM 175 - 124 - SX/DX

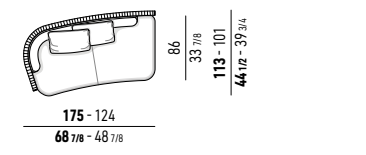

ELEMENTI CENTRALI | CENTRAL ELEMENTS

ELEMENTO CENTRALE CM 124
CENTRAL ELEMENT CM 124

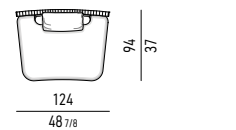

ELEMENTO CENTRALE CM 268X213 - 216X176 - SX/DX - DOPPIA PROFONDITÀ
CENTRAL ELEMENT CM 268X213 - 216X176 - SX/DX - DOUBLE DEPTH

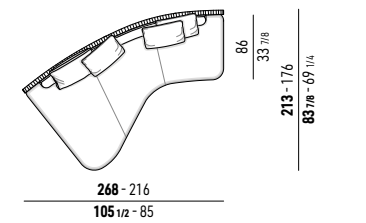

ELEMENTO TERMINALE CM 260X192 - SX/DX - DOPPIA PROFONDITÀ
ELEMENT WITH 1 ARMREST CM 260X192 - SX/DX - DOUBLE DEPTH

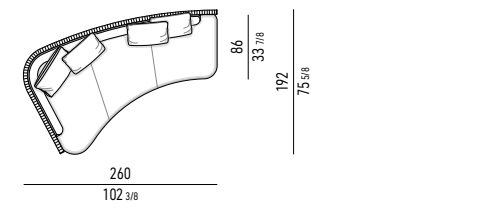

ELEMENTO ANGOLARE | CORNER ELEMENT

ELEMENTO ANGOLARE CM 197X186
CORNER ELEMENT CM 197X186

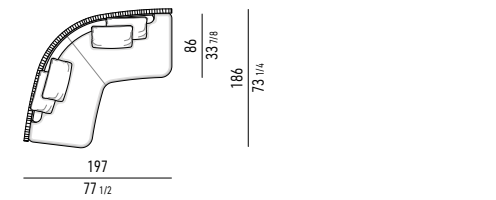

POUF | OTTOMANS

POUF CM 129X114 - 93X78 H42
OTTOMAN CM 129X114 - 93X78 H42

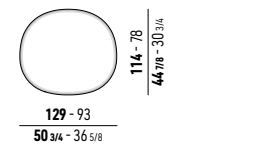

POUF CM 114X156 - 78X121 H42
OTTOMAN CM 114X156 - 78X121 H42

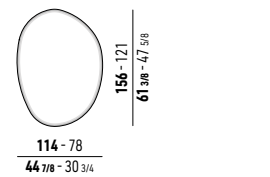

CUSCINI OPTIONAL | OPTIONAL CUSHIONS

CUSCINO SCHIENALE OPTIONAL CM 65X60
OPTIONAL BACKREST CUSHION CM 65X60



CUSCINO OPTIONAL CM 55X55
OPTIONAL CUSHION CM 55X55



OPTIONAL RAIN COVER

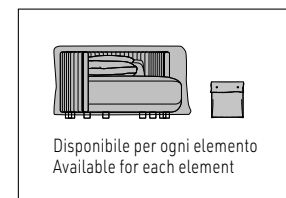

PIEDINI E BASE POUF FEET AND OTTOMAN BASE

ACCIAIO INOX STAINLESS STEEL

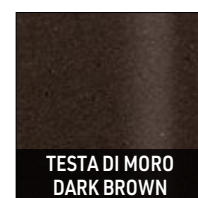

STRUTTURA STRUCTURE

ALLUMINIO OPACO
MATT ALUMINIUM

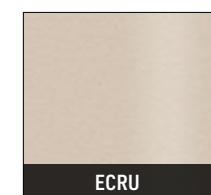

RIVESTIMENTO STRUTTURA STRUCTURE COVER

FILATO POLIPROPILENE
POLYPROPYLENE CORD

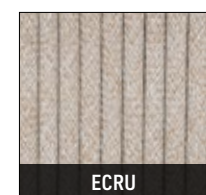

STRUTTURA STRUCTURE

ALLUMINIO OPACO
MATT ALUMINIUM

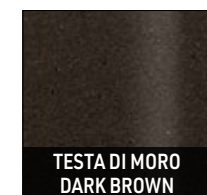

RIVESTIMENTO STRUTTURA STRUCTURE COVER

FILATO POLIPROPILENE
POLYPROPYLENE CORD

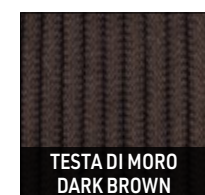

STRUTTURA STRUCTURE

ALLUMINIO OPACO
MATT ALUMINIUM

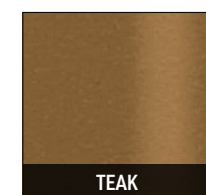

RIVESTIMENTO STRUTTURA STRUCTURE COVER

FILATO POLIPROPILENE
POLYPROPYLENE CORD

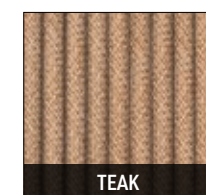

EMMI CORD OUTDOOR

HANNES PEER DESIGN



DIVANO CM 190 SOFA CM 190

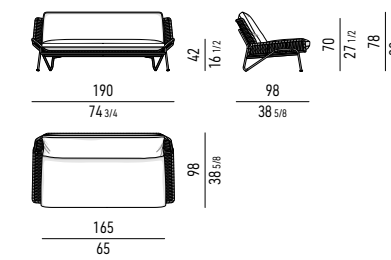

POLTRONA CM 97 ARMCHAIR CM 97

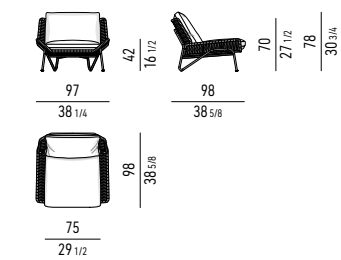

POGGIAPIEDI CM 88 FOOTSTOOL CM 88

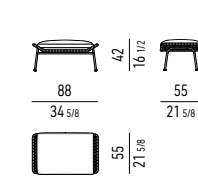

CUSCINI OPTIONAL | OPTIONAL CUSHIONS

RULLO OPTIONAL CM 70
OPTIONAL ROLL CM 70

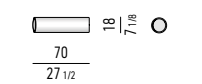

ESEMPIO DI UTILIZZO
HOW TO USE

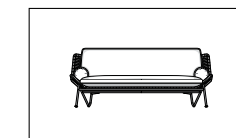

CUSCINO OPTIONAL CM 50X50
OPTIONAL CUSHION CM 50X50

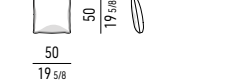

OPTIONAL RAIN COVER



STRUTTURA E PUNTALE STRUCTURE AND TIP

ACCIAIO INOX OPACO
MATT STAINLESS STEEL

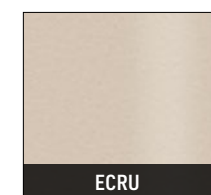

RIVESTIMENTO STRUTTURA STRUCTURE COVER

FILATO POLIPROPILENE
POLYPROPYLENE CORD

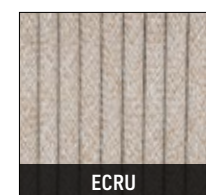

STRUTTURA E PUNTALE STRUCTURE AND TIP

ACCIAIO INOX OPACO
MATT STAINLESS STEEL

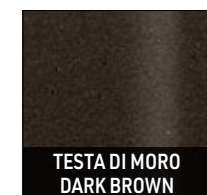

RIVESTIMENTO STRUTTURA STRUCTURE COVER

FILATO POLIPROPILENE
POLYPROPYLENE CORD

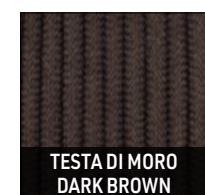

STRUTTURA E PUNTALE STRUCTURE AND TIP

ACCIAIO INOX OPACO
MATT STAINLESS STEEL

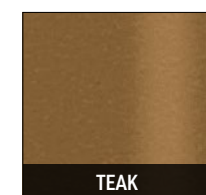

RIVESTIMENTO STRUTTURA STRUCTURE COVER

FILATO POLIPROPILENE
POLYPROPYLENE CORD

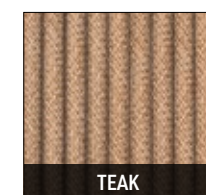

ANDRÉE OUTDOOR

HANNES PEER DESIGN

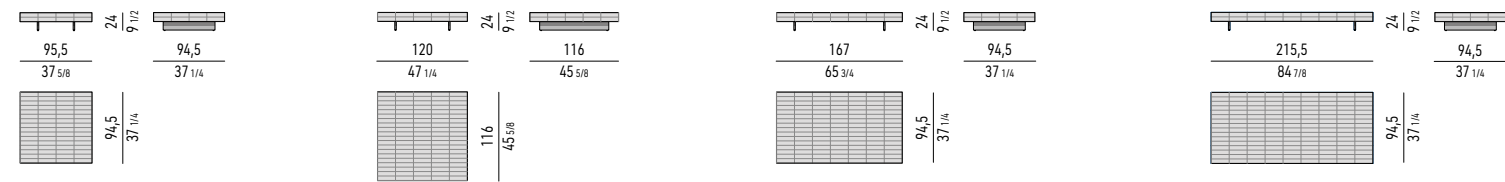

OPTIONAL RAIN COVER

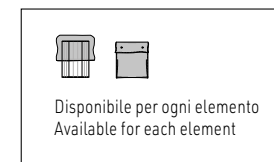

TAVOLINI ESAGONALI | HEXAGONAL COFFEE TABLES

**RIVESTIMENTO STRUTTURA
STRUCTURE COVER**

**CERAMICA SMALTATA
GLAZED CERAMIC**

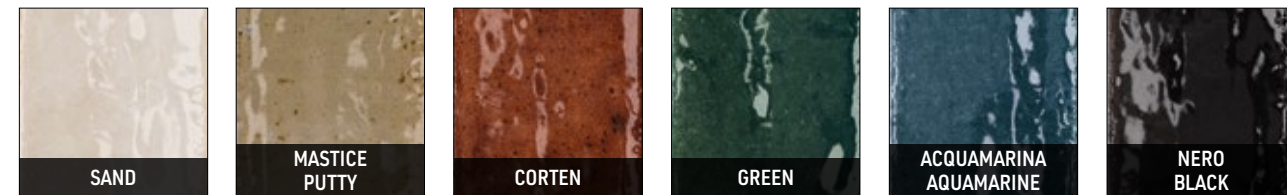

**PIASTRE
PLATES**

**ALLUMINIO OPACO
MATT ALUMINIUM**

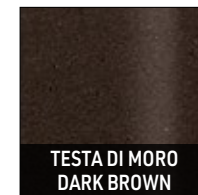

TAVOLINI QUADRATI E RETTANGOLARI | SQUARED AND RECTANGULAR COFFEE TABLES

**RIVESTIMENTO STRUTTURA
STRUCTURE COVER**

**CERAMICA SMALTATA
GLAZED CERAMIC**

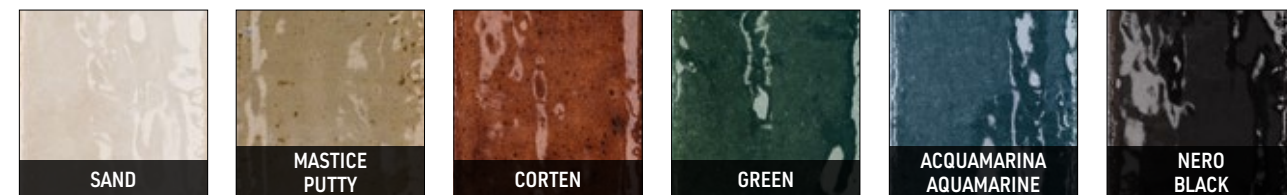

**GAMBE
LEGS**

**ALLUMINIO LUCIDO
POLISHED ALUMINIUM**



BÉZIER OUTDOOR

MARCIO KOGAN / STUDIO MK27 DESIGN



**TAVOLINO CM 105X80 H24
COFFEE TABLE CM 105X80 H24**

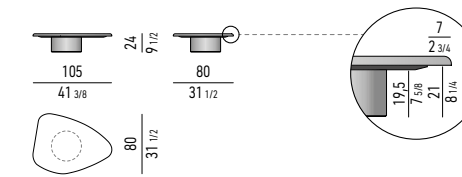

**TAVOLINO CM 151,5X97 H20
COFFEE TABLE CM 151,5X97 H20**

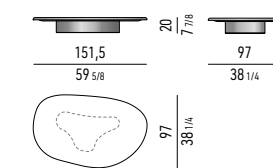

**TAVOLINO CM 151,5X97 H28
COFFEE TABLE CM 151,5X97 H28**

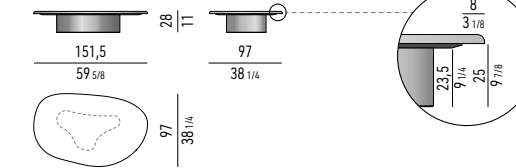

**TAVOLINO CM 143X138 H20
COFFEE TABLE CM 143X138 H20**

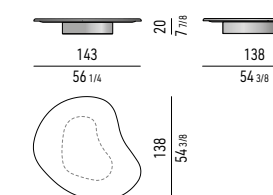

**TAVOLINO CM 143X138 H28
COFFEE TABLE CM 143X138 H28**

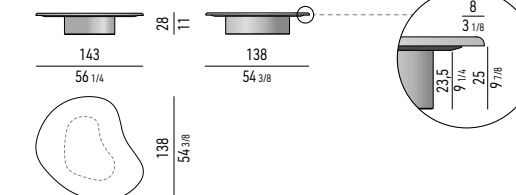

**TAVOLINO CM 172,5X131 H20
COFFEE TABLE CM 172,5X131 H20**

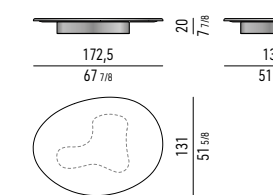

**TAVOLINO CM 172,5X131 H28
COFFEE TABLE CM 172,5X131 H28**

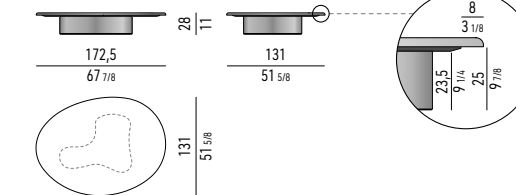

**TAVOLINO CM 206X101 H20
COFFEE TABLE CM 206X101 H20**

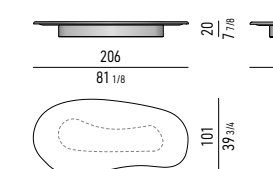

**TAVOLINO CM 206X101 H28
COFFEE TABLE CM 206X101 H28**

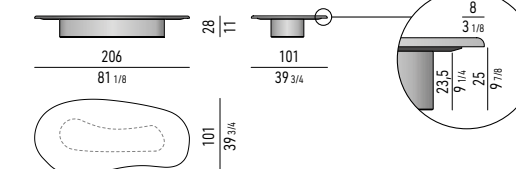

OPTIONAL RAIN COVER

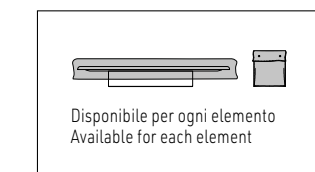

**PIANO
TOP**

**PIETRA
STONE**



**BASE
BASE**

**ACCIAIO INOX
STAINLESS STEEL**

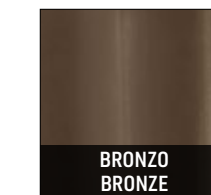

**ACCIAIO INOX MATERICO
TEXTURED STAINLESS STEEL**

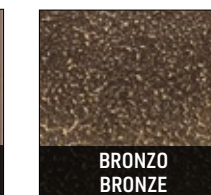

TAIKO OUTDOOR (UPDATE) NENDO DESIGN

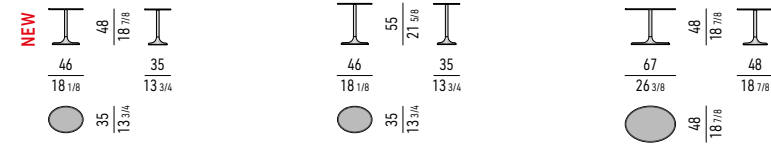

OPTIONAL RAIN COVER

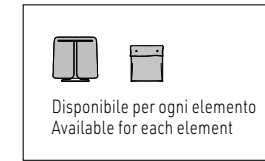

ANDRÉE DINING OUTDOOR HANNES PEER DESIGN

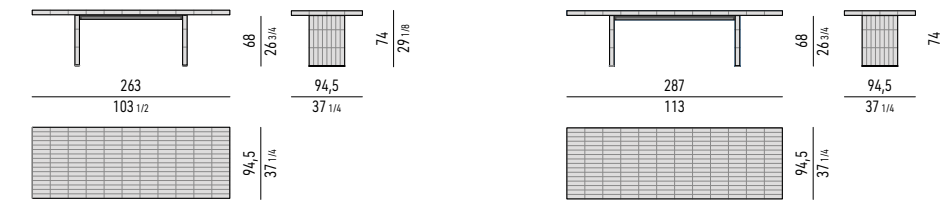

OPTIONAL RAIN COVER

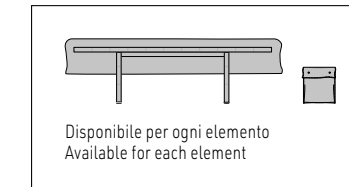

SAND

MASTICE | PUTTY

CORTEN



GREEN

ACQUAMARINA | AQUAMARINE

NERO | BLACK

**PIANO E BASE
TOP AND BASE**

**ALLUMINIO LUCIDO
POLISHED ALUMINIUM**

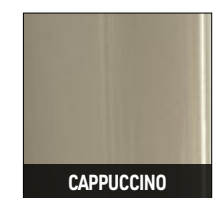

NEW 2025 FINISH

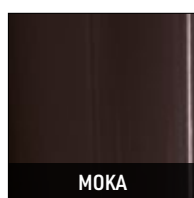

NEW 2025 FINISH

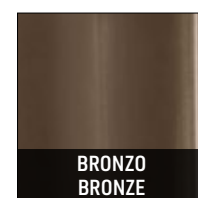

**ALLUMINIO OPACO
MATT ALUMINIUM**

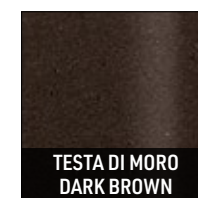

**RIVESTIMENTO STRUTTURA
STRUCTURE COVER**

**CERAMICA SMALTATA
GLAZED CERAMIC**

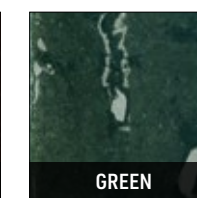
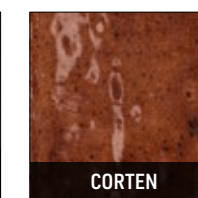



COUPÉ GIAMPIERO TAGLIAFERRI

Una silhouette distintiva, caratterizzata da volumi tondeggianti sovrapposti di chiara matrice anni '60 e '70, dà vita al sistema di sedute Coupé di Giampiero Tagliaferri.

Il designer considera il progetto “una vera e propria seating experience nostalgica, ma al contempo lungimirante: abbiamo reinterpretato le forme classiche attraverso una lente contemporanea, trovando un equilibrio tra fascino vintage e funzionalità moderna.” Il richiamo all'estetica del modernismo del XX secolo si sintetizza nelle forme morbide, oltre che nei preziosi dettagli couture come le cuciture longitudinali, volutamente tono su tono, presenti nella versione in pelle: un elegante tratto grafico, espressione dell'alta manifattura artigianale firmata Minotti, che scandisce l'intero volume a partire dal poggiatesta, passando in coincidenza con i bottoni sullo schienale, fino a percorrere tutta la seduta. Le forme avvolgenti e la sinuosità ergonomica di Coupé, garantita dall'inclinazione del sedile appositamente progettata per conferire il massimo comfort, si incrociano con la forte orizzontalità degli elementi imbottiti di poggiatesta e poggiaereni, creando un'accattivante dinamicità visiva che sfocia nella vista del bracciolo, a evidenziare la sezione del divano.

“Alla base di questo design c'è un profondo rispetto per il passato, un omaggio a un'epoca in cui i divani abbracciavano il corpo con sedute inclinate, offrendo raffinatezza e un comfort senza precedenti”, conferma Tagliaferri. Contraddistinto da un ampio abaco, il programma permette di disegnare layout flessibili e di prevedere sia l'aggregazione di sedute che l'utilizzo di elementi singoli in modo indipendente; tra loro spicca un couch, dalle proporzioni decisamente generose, caratterizzato da una doppia inclinazione. Dal tratto fortemente riconoscibile, questo sistema presenta, sul fronte e sul retro della base imbottita, una cornice curva in alluminio verniciato o spazzolato lucido, che protegge il rivestimento valorizzando al contempo l'intera silhouette.

A distinctive silhouette, characterised by overlapping rounded volumes with a clear 60s and 70s influence, brings the Coupé seating system by Giampiero Tagliaferri to life. The designer describes the project as “a seating experience that is both nostalgic and forward-thinking: we have reinterpreted classic forms through a contemporary lens, finding a balance between vintage charm and modern functionality”. The reference to the aesthetics of 20th-century modernism is encapsulated in the soft forms, and in the precious couture-inspired details, such as the longitudinal stitching, intentionally tone-on-tone, featured in the leather version: an elegant graphic element, a mark of Minotti's refined craftsmanship, which runs along the entire volume, starting from the headrest, touching on the buttons on the backrest, and continuing across the seat. The enveloping shapes and ergonomic sinuosity of Coupé, delivered by the inclined seat specifically designed to ensure maximum comfort, intersect with the strong horizontality of the padded headrest and lumbar cushion elements, creating an engaging visual dynamism that culminates in the view of the armrest, highlighting the profile of the sofa.

“At the heart of this project lies a deep respect for the past, an homage to an era when sofas embraced the body with inclined seating, offering both aesthetic grace and unparalleled comfort”, confirms Tagliaferri. Distinguished by a broad selection of options, the system can be used to create infinite flexible layouts, allowing for both the combination of seating elements and the use of individual pieces independently. Among them, a standout is the couch, with its generous proportions and unique double inclination. With its highly distinctive design, this system features a curved aluminium frame, either varnished or brushed polished, on the front and back of the upholstered base, not only protecting the upholstery, but also enhancing the entire silhouette.



BÉZIER MARCIO KOGAN / STUDIO MK27

Ben oltre il concetto di divano, il sistema Bézier si connota come un insieme di sedute organiche e aggregabili all'infinito per composizioni sempre diverse e adattabili.

Firmato dallo Studio MK27, il cui fondatore Marcio Kogan ha fatto del rigore delle sue linee un tratto distintivo, Bézier sperimenta e interpreta un linguaggio compositivo inedito e di grande impatto, sviluppato con volumi irregolari e linee fluide che disegnano e abbracciano lo spazio e chi lo utilizza. “L'intero universo è fatto di curve” dice Kogan, citando il maestro Oscar Niemeyer.

E le curve del sistema Bézier sono enfatizzate dalla seduta estremamente confortevole e caratterizzata da una morbidezza ottenuta grazie all'accurata stratificazione di poliuretani a quote differenziate ad alta densità che permettono un comfort omogeneo su tutta la superficie. Trattandosi di forme organiche, la lavorazione sartoriale delle cuciture è estremamente accurata, seguendo alla perfezione le sinuosità degli elementi. Inoltre, collocato lungo tutto lo schienale, un cuscino poggiaereni conferisce ulteriore relax, diventando anche un motivo decorativo.

Il sistema Bézier è un omaggio alla fusione tra matematica e arte, ispirata all'eredità di Pierre Bézier, la cui famosa curva parametrica, spesso usata in computer grafica, celebra la precisione e la fluidità delle forme organiche. Questo sistema di sedute dalla grande versatilità, con le sue ampie forme che si espandono fino a diventare isole, permette di creare nuovi modi di vivere il living, non solo in ambienti domestici, ma anche Hospitality: un'innovativa modalità di approcciarsi al divano che da oggetto si trasforma in luogo di incontro e di aggregazione.

Come è caratteristico del DNA di Studio MK27, la collezione Bézier rende omaggio al modernismo brasiliano e celebra la libertà della curva come soluzione della natura: emozione e funzionalità in perfetto equilibrio.

Far beyond the concept of a traditional sofa, the Bézier system is defined by a series of organic, infinitely combinable seating elements, allowing for endlessly adaptable configurations.

Designed by Studio MK27, whose founder Marcio Kogan has made the precision of his lines into a distinctive hallmark, Bézier explores and reinterprets a novel and striking compositional language. It is developed through irregular volumes and fluid forms that shape and embrace both the space and those who inhabit it. “The entire universe is made of curves”, says Kogan quoting the master Oscar Niemeyer.

And the curves of the Bézier system are enhanced by its exceptionally comfortable seat, achieved through the precise layering of high-density polyurethane in varying thicknesses, ensuring uniform comfort across the entire surface. Given the organic shapes, the tailoring of the seams is extremely accurate, perfectly following the curves of each element. Furthermore, located all along the backrest, a lumbar cushion provides greater relaxation while also serving as a decorative element.

The Bézier system is a tribute to the fusion of mathematics and art, inspired by the legacy of Pierre Bézier, whose famous parametric curve, often used in computer graphics, celebrates the precision and fluidity of organic shapes. Highly versatile, with its generous forms that stretch to become islands, it creates new ways to experience the living space, not only in home environments, but also in Hospitality settings. It is an innovative approach to the sofa, transforming it from a mere object into a place of meeting and gathering.

As is characteristic of the DNA of Studio MK27, the Bézier collection pays tribute to Brazilian modernism and celebrates the freedom of the curve as a solution inspired by nature: emotion and functionality in perfect balance.



RILEY HANNES PEER

Un motivo geometrico sinuoso definisce l'identità del sistema di sedute Riley di Hannes Peer. Dall'estetica senza tempo, espressione tipica del linguaggio stilistico Minotti, l'architetto la definisce come “una seduta dinamica e flessibile che interpreta l'abbraccio di due anime perfettamente complementari in equilibrio tra compostezza ed espressività, rigore e naturalezza, solidità e fluidità: una prima, che coincide con l'esterno del volume dello schienale, marcatamente architettonico, e una seconda all'interno, più morbida, caratterizzata da un forte segno decorativo, che invita ad accomodarsi.”

Dallo zoccolo metallico arretrato, il volume della seduta a pozzetto si innalza monolitico e solido, arricchito da leggere trapuntature verticali che ritmano schienale e bracciolo, mentre un profilo più profondo, rivestito in pelle, a contrasto o in abbinamento cromatico al rivestimento scelto per il divano, diventa il tratto distintivo del progetto. Una traccia, una linea continua, curva e retta, che accarezza lo schienale squadrato e il bracciolo fino a disegnare un taglio a goccia con inclinazione a 45 gradi in corrispondenza dell'angolo tra il bracciolo e il sedile, trasformando il divano in inedito oggetto couture. La cuscinatura della seduta è intera, accolta parzialmente nella base imbottita e impreziosita da una fascia di 5 cm. La possibilità di avere elementi con due diverse profondità di seduta conferisce a questo sistema non solo maggiore comfort, ma anche un gioco interessante di volumi abbinabili tra loro.

I cuscini addizionali “relax”, invece, fungono da poggiatesta, grazie ad una struttura interna in alluminio multidirezionale modellabile a piacimento, completamente avvolta da una stratificazione sofisticata di poliuretani, capace di conferire il massimo comfort.

In aggiunta, la ricca gamma cromatica delle finiture possibili per il rivestimento del profilo cucito, oltre che la confezione ricercata, contribuiscono a rendere Riley un arredo esclusivo e unico nel suo genere nel suo classico rigore senza tempo.

A sinuous geometric pattern defines the identity of the Riley seating system by Hannes Peer. With a timeless aesthetic, characteristic of Minotti's stylistic language, it is defined by the architect as “a dynamic and versatile design that interprets the embrace of two perfectly complementary souls, balanced between restraint and expressiveness, rigour and ease, permanence and fluidity. One is distinctly architectural, outward-facing, while the other is softer on the interior, featuring a strong decorative sign that extends an invitation to relax”.

From the recessed metal base, the volume of the seat rises monolithic and solid, enriched with light vertical quilting that gives rhythm to the backrest and armrest. Meanwhile, a deeper profile, upholstered in leather in contrast or colour-matched to the upholstery chosen for the sofa, becomes the distinctive feature of the design. A trace, a continuous line, both curved and straight, that follows the square backrest and armrest, creating a teardrop-shaped cut with a 45-degree inclination at the junction between the armrest and the seat, transforming the sofa into a unique couture-inspired piece. The seat cushion is a single element, partially housed in the padded base, and enhanced with a 5 cm-wide decorative band. The possibility to have elements with two different seat depths not only adds greater comfort to this system but also creates an interesting interplay of volumes that can be combined. The additional “relax” cushions, on the other hand, serve as headrests, thanks to an internal, multidirectional aluminium frame that can be shaped as desired, fully enveloped in a sophisticated layering of polyurethanes, offering maximum comfort. In addition, the wide range of colour finishes available for the stitched profile, along with the exquisite craftsmanship of the upholstery, help make Riley an exclusive and refined piece, one of a kind in terms of its timeless, classic elegance.



VIVIENNE GAMFRATESI

Dalla curva ad emiciclo dello schienale della poltrona Vivienne, nasce l'omonimo sistema di sedute dall'estetica contemporanea firmato dal duo di progettisti italo-danese GamFratesi. L'abbraccio dello schienale che avvolge la seduta diventa anche bracciolo, donando al divano un gusto particolarmente decorativo. Si tratta di un progetto caratterizzato da una base imbottita finemente sagomata, sostenuta da barre in alluminio arretrate, che accoglie e parzialmente cela lo spessore della cuscinatura che, alla vista, appare più sottile: un dettaglio che dona all'imbottito un aspetto più delicato, rendendolo leggero se pur estremamente comodo. I progettisti parlano di questo sistema di sedute come di “un pezzo che gioca con l'armonia delle forme.

Le sue curve morbide e generose, tipiche della poltrona Vivienne Large, si evolvono in un sistema di divani dalle proporzioni nuove: un equilibrio perfetto tra sinuosità e rigore geometrico, tra il decorativo e l'essenziale, che lo rende adatto a qualsiasi ambiente moderno, pur mantenendo un carattere iconico e organico.”

Vivienne è un sistema dalla grande versatilità compositiva, che oltre a divani, elementi terminali e chaise-longue, comprende anche elementi con piani d'appoggio, dando così vita ad originali combinazioni e creando uno stile coerente per ambienti di diverse dimensioni.

The Vivienne seating system is inspired by the semicircular curved backrest of the Vivienne armchair, featuring a contemporary aesthetic designed by Italian-Danish duo GamFratesi. The embrace of the backrest that wraps around the seat also acts as an armrest, giving it a particularly decorative flair. The project features a finely contoured upholstered base, supported by recessed aluminium bars, which hosts and partially conceals the thickness of the cushions. As a result, the seat appears thinner – a detail that gives the upholstery a more delicate look, making it feel light while remaining incredibly comfortable. The designers describe this seating system as “a piece that plays with the harmony of shapes. Its soft and generous curves, typical of the Vivienne Large armchair, evolve into a sofa system with new proportions. A perfect balance between sinuosity and geometric rigour, between the decorative and the essential, making it suitable for any modern space while maintaining an iconic and organic character.” Vivienne is a system that offers great compositional versatility, and, in addition to sofas, end pieces and chaise lounges, it also includes elements with tops, thus giving rise to original combinations and creating a cohesive style for spaces of different sizes.



SAKI NENDO

In Giappone il termine “Saki” indica la fioritura ed è proprio allo schiudersi dei boccioli che Nendo rende omaggio con una famiglia di sedute definite dalla presenza di sinuosi pannelli di sostegno per schienale e braccioli. Laccati in diverse nuance o rivestiti in tessuto o pelle, consentono di ottenere molteplici combinazioni, conferendo così un'estetica ricercata ed eclettica agli arredi.

Realizzata secondo un concept di aggregabilità, Saki é disponibile nelle varianti divano a 2, 3 o 4 posti con due diverse profondità, nella versione poltrona con e senza braccioli, panche ed originali isole disponibili in diverse configurazioni.

Il sistema presenta ampie sedute dalla silhouette curvilinea, rifinite da un piping perimetrale che ne definisce elegantemente il profilo. Oki Sato interpreta il simbolo del bocciolo “nelle sottili incisioni praticate sulla parte superiore della cuscinatura in corrispondenza dell'angolo, che creano una separazione e una coesione ben equilibrate, passando senza soluzione di continuità dallo schienale al bracciolo.” Un movimento leggero e sinuoso che si traduce in un comfort avvolgente e protettivo, dato anche dalla morbidezza dei cuscini con struttura interna sagomata, frutto di un'attenta progettazione ergonomica. La declinazione a isola quadrata, la cui superficie è arricchita da cuciture che si incrociano al centro, è particolarmente accogliente e può rivelarsi una spaziosa seduta sulla quale sdraiarsi o accomodarsi in più persone lungo il suo perimetro, in spazi lounge, domestici o Hospitality. Oltre alle sue caratteristiche sartoriali, è impregiosita da piedi curvilinei in alluminio dall'estetica dinamica, presenti anche in tutti gli altri elementi della famiglia. La poltrona è disponibile anche con un ulteriore appoggio a terra costituito da una base quadrata con angoli stondati, sia nella versione girevole che fissa.

In Japan, the term “Saki” means blooming, and it is precisely to the unfolding of flower buds that Nendo pays tribute with a family of seats, characterised by the presence of sinuous support panels for the backrest and armrests. These panels can be lacquered in various shades or upholstered in fabric or leather, allowing for endless combinations, giving each furnishing piece a refined and eclectic aesthetic. Based on a concept of modularity, Saki is available in 2-, 3-, or 4-seat sofa versions with two different depths, in an armchair version with or without armrests, in benches and in original island-like elements, available in various configurations. The system features large seats with a curvilinear silhouette, embellished with a perimeter piping that elegantly defines its profile. Oki Sato interprets the symbol of the bud “in the subtle incisions made on the top of the cushion, at the corner, creating a well-balanced separation and cohesion, seamlessly transitioning from the backrest to the armrest.” A light and sinuous movement, translating into an enveloping and protective comfort, further enhanced by the softness of the cushions featuring a moulded internal structure, the result of meticulous ergonomic design. The square island version, whose surface is enriched with stitching that intersects at the centre, is particularly inviting and can be used as a spacious seating area where multiple people can lie out or sit along its perimeter, in lounge, residential, or hospitality spaces. In addition to its tailored features, it is enhanced by curvilinear aluminium feet with a dynamic aesthetic, also used for all the other elements in the family. The armchair is also available with an additional floor support consisting of a square base with rounded corners, in both swivel and fixed versions.



LIBRA GIAMPIERO TAGLIAFERRI

Ispirata all'estetica anni '70, la poltrona Libra disegnata da Giampiero Tagliaferri è composta dalla sovrapposizione di morbidi volumi di seduta, schienale e poggiatesta rivestiti in pelle o tessuto, impreziositi da puntuali impunture al centro delle cuscinate che ne aumentano l'effetto sartoriale e tridimensionale. Un gioco di equilibri volumetrici da cui trae anche il nome: Libra in latino significa infatti la “bilancia”. La ricercata arricciatura lungo l'intero perimetro dei volumi imbottiti di bergère, poltrona, pouf e poltroncina dining è rifinita mediante un piping, che calibra le morbide pieghe del rivestimento e ne valorizza la sofisticata manifattura artigianale. La singolare base in metallo è costituita da piedi realizzati in tubolare e da una piastra curvilinea sulla quale poggia la seduta.

Inspired by 1970s aesthetics, the Libra armchair designed by Giampiero Tagliaferri is composed of overlapping soft volumes of the seat, backrest, and headrest, upholstered in leather or fabric, embellished with precise stitching at the centre of the cushions that amplifies the tailored and three-dimensional effect. An interplay of volumetric balances from which it also takes its name: Libra, in Latin, means scale. The refined curling along the entire perimeter of the padded volumes of the bergère, armchair, ottoman, and dining little armchair is finished with a piping, which carefully shapes the soft folds of the upholstery, enhancing its sophisticated artisanal craftsmanship. The unique metal base consists of tubular legs and a curvilinear plate that supports the seat.



LAUREL GIAMPIERO TAGLIAFERRI

La poltrona e la poltroncina dining firmate da Giampiero Tagliaferri attingono a forme ed elementi stilistici Mid-Century per un progetto unico e senza tempo.

La scocca delle sedute - disponibile in essenza o rivestita in pelle - accoglie i cuscini di seduta e schienale, ritmati da impunture sartoriali, e si innalza verso l'alto per sostenere la morbida cuscinate dei braccioli.

Il retro della poltrona, dalla forte personalità, è arricchito da una fascia in tessuto o in pelle, come fosse una martingala, in corrispondenza di due preziose borchie in metallo poste sui lati della scocca, presenti anche nella variante poltroncina.

La base della poltrona girevole è costituita da razze in metallo piegate e fissate a un montante verticale in finitura cromo o Black Coffee, mentre la variante poltroncina dining, dalla silhouette più aerea, presenta esili gambe in metallo.

Laurel armchair and dining little armchair designed by Giampiero Tagliaferri draw inspiration from Mid-Century forms and stylistic elements to create a unique and timeless design. The shell of the seats - available in wood or upholstered in leather - accommodates the seat and back cushions, tailored with stitching, and rises upward to support the soft cushioning of the armrests.

The back of the armchair, with its strong personality, is enriched with a fabric or leather band, resembling a martingale, at two precious metal studs on the sides of the shell, also present in the dining little armchair version. The base of the swivel armchair consists of bent metal spokes fixed to a vertical upright in chrome or Black Coffee finish, while the dining armchair variant, with a more aerial silhouette, features slender metal legs.



TAPE DINING (UPDATE) NENDO

Firmata dall'eclettico studio giapponese Nendo, diretto da Oki Sato, Tape è una poltroncina che segue la silhouette dell'originaria famiglia di sedute aumentandone leggermente gli spessori per dare maggiore comfort visivo, pur mantenendo la spiccata personalità. La linea raffinata e avvolgente è sottolineata dalla curva morbida della scocca che disegna il bracciolo e che accoglie un cuscino poggiatesta dalle forme morbide.

La sua base metallica verniciata Black Coffee contrasta elegantemente con le molteplici finiture in pelle o tessuti delle imbottiture della seduta.

Le proporzioni compatte e confortevoli, il movimento girevole a 360° con ritorno, nonché le linee iconiche e distintive, rendono Tape una poltroncina adatta tanto agli ambienti domestici quanto a quelli Hospitality.

Designed by the eclectic Japanese studio Nendo, directed by Oki Sato, Tape is a dining little armchair that follows the same silhouette of the original family of seats, slightly increasing the thicknesses to provide greater visual comfort, while maintaining its distinctive personality. The refined, enveloping line is accentuated by the soft curve of the shell, which shapes the armrest and accommodates a softly shaped lumbar cushion.

Its Black Coffee-painted metal base elegantly contrasts with the various leather or fabric finishes of the seat upholstery.

The compact and comfortable proportions, the 360° swivel movement with return, and the iconic and characteristic lines make Tape a little armchair suitable for both residential and hospitality spaces.



TRIO DINING (UPDATE) MARCIO KOGAN / STUDIO MK27

Dal progetto della poltrona Trio prende forma la nuova versione dining, in cui il design razionalista di Marcio Kogan / Studio MK27 si unisce al know-how manifatturiero di Minotti, facendo emergere l'uso sapiente e combinato di tre diversi materiali - pelle o tessuto, legno e metallo - per seduta e struttura. Quest'ultima accoglie una morbida imbottitura di seduta e schienale, rendendo la poltroncina dining Trio un arredo esile ed esteticamente leggero, ma estremamente confortevole e ideale per i momenti di convivialità.

From the design of the Trio armchair takes shape the new dining version, in which the rationalist design of Marcio Kogan / Studio MK27 joins Minotti's manufacturing know-how, bringing out the skilful and combined use of three different materials - leather or fabric, wood and metal - for the seat and frame. The latter features a soft upholstery for the seat and backrest, making the Trio dining little armchair a sleek and aesthetically light furnishing piece, yet extremely comfortable and ideal for moments of conviviality.



SENDAI DINING (UPDATE) INODA+SVEJE

Nasce dal tratto raffinato e aereo dell'omonima famiglia di sedute la nuova versione della poltroncina dining Sendai. Dalla silhouette compatta e ben proporzionata, presenta esili gambe in metallo verniciato lucido Black Coffee, che appoggiano a terra con un puntale Black Nickel o Cromo Champagne: un dettaglio decorativo che aggiunge un tocco prezioso all'arredo.

The new dining little armchair version of Sendai originates from the refined and aerial design of the Sendai seating collection. Boasting a compact, well-proportioned silhouette, it features slender legs in glossy Black Coffee varnished metal, resting on Black Nickel or Champagne Chrome feet: a decorative detail that adds a refined touch to the furnishing piece.



YOKO DINING (UPDATE) INODA+SVEJE

Dalle linee leggere ed eleganti della poltroncina dining Yoko nasce una nuova versione senza braccioli. La grande competenza nella lavorazione del legno, che da sempre si coltiva sia in terra nordica che nipponica, si traduce in questo progetto di seduta grazie all'uso colto della materia lignea: la parte superiore delle gambe è rifinita a forma lenticolare, mentre un dettaglio decorativo in metallo è presente su entrambe le gambe posteriori, in prossimità dello schienale.

From the light and elegant lines of the Yoko dining little armchair comes a new version without armrests. The great expertise in wood-sanding, long cultivated in both Nordic and Japanese lands, is translated into this seating design through the refined use of the wooden material: the upper part of the legs is finished in a lenticular shape, while a decorative metal detail is present on both rear legs, near the backrest.



LIBRA COFFEE TABLE GIAMPIERO TAGLIAFERRI

Progettato da Giampiero Tagliaferri, Libra è un coffee table da centro stanza di forma rettangolare e quadrata dalla linea spiccatamente moderna, contraddistinto da ricercati dettagli costruttivi che rimandano all'estetica e alla geometria del tavolo Libra.

Il top si presenta con una sezione a "C" rovesciata, proposto in marmo, pietra o in essenza, arricchito da una fascia arretrata in metallo cromato, posta in corrispondenza dei lati corti. Le gambe sono costituite da basi ottenute da tubolari cromati lucidi sui quali poggia una piastra metallica che regge il piano, rendendo il tavolino visivamente leggero.

Designed by Giampiero Tagliaferri, Libra is a coffee table with a distinctive modern design in two shapes: rectangular and square. It is characterised by refined construction details that evoke the aesthetics and geometry of the Libra table. The top features an inverted "C" section, in marble, stone or wood, and is accentuated by a recessed chrome metal band along the shorter sides. The legs consist of bases made from polished chrome tubular elements, supporting a metal plate that holds the top, giving the coffee table a visually light appearance.



ANDRÉE HANNES PEER

Ispirata alle facciate dell'architettura milanese degli anni '70, questa collezione di tavolini di forma rettangolare e quadrata è pensata per conferire personalità e un forte segno decorativo agli spazi residenziali, tanto per l'indoor quanto per l'outdoor. Alla sua rigorosa geometria fa da contrappunto la texture della piastrella in ceramica smaltata, che le conferisce un peculiare tratto artigianale ma, soprattutto, la fa vibrare nella luce, animando l'area living. La scelta di questo materiale, mai uguale a se stesso, rende ogni tavolino affascinante per la sua unicità e al contempo altamente resistente proprio per le sue caratteristiche tecniche.

Tutti gli spigoli sono incorniciati da bordature in ottone cromato che impreziosiscono le singole facce e che contengono lo spessore del rivestimento, rendendo più leggero il design dell'arredo che appare come sospeso grazie ai piedi arretrati in essenza. Proposto in svariate nuance, perfettamente in linea con le cromie che hanno caratterizzato gli anni '70, la versione più eclettica e polifunzionale a forma di prisma è prevista con piano d'appoggio in ottone cromato e profili in alluminio cromato.

Inspired by the facades of the 1970s Milanese architecture, this collection of rectangular and square coffee tables is designed to bring personality and a strong decorative mark to residential spaces, both indoors and outdoors.

Its rigorous geometry is counterpointed by the texture of the glazed ceramic tile, which gives it a distinctive artisanal touch but, above all, makes it shimmer in the light, animating the living area. The choice of this material, which is never the same twice, makes each coffee table fascinating for its uniqueness, as well as extremely durable due to its technical properties.

All the edges are framed by chrome-plated brass trims that embellish each surface and contain the thickness of the covering, giving the design a lighter feel. The piece appears to float, an effect emphasised by the recessed wooden feet. Available in a variety of shades, perfectly in line with the colour palette that characterised the 1970s, the most eclectic and multifunctional prism-shaped version features a chrome-plated brass top and chrome-plated aluminium profiles.



YVES COFFEE TABLE AND CONSOLE TABLE HANNES PEER

La famiglia di tavolini Yves, progettata da Hannes Peer in perfetta continuità estetica con l'omonimo sistema di sedute, è costituita da un piano quadrato, rettangolare o tondo che appare come sospeso sulle caratteristiche gambe modanate con doppio torello, disposte a correre, e proposta in finitura cromo nero, cromo Champagne o in alluminio ottonato acidato dall'elegante colore giallo-dorato.

Un arredo dall'estetica particolarmente decorativa e dalle proporzioni eleganti, disponibile nella versione con top in essenza oppure in una vasta gamma di pregiati marmi o pietre. Con la stessa geometria architettonica si sviluppa anche la consolle Yves, disponibile nelle medesime finiture del tavolino, con top di forma irregolare e, che appare sospeso sulle gambe sempre a doppio torello e disposte in modo asimmetrico.

The Yves family of coffee tables, designed by Hannes Peer in perfect aesthetic continuity with the Yves seating system, features a square, rectangular or round top that seems to float on the signature double shaped rounded legs, which run continuously along the base and are available in black chrome, Champagne-colour chrome finish, or in acid-etched brass-plated aluminium with an elegant yellow-gold finish.

A furnishing piece which features a distinctly decorative aesthetic and refined proportions, distinguished by a wooden top or in a wide selection of precious marble or stone options. The Yves console is developed following the identical architectural geometry, available in the same finishes as the coffee table, presenting an irregular form top. It appears to be suspended on the signature double shaped rounded legs, arranged asymmetrically.



STAGE HANNES PEER

Il side table Stage, di forma rettangolare, quadrata o trapezoidale, si configura come un pratico piano d'appoggio da utilizzare tra le sedute o come tavolino fianco divano, grazie alla sua estetica dalle geometrie decise. Progettato da Hannes Peer, è costituito da una struttura portante in acciaio in due finiture che sostiene due ripiani con bordi smussati in essenza o laccati lucidi: nelle versioni rettangolare e quadrata, Stage presenta anche una variante con piano superiore scorrevole che cela un comodo scompartimento portaoggetti. Dalla linea elegante che richiama forme e cromie del design milanese di fine anni '70, questo tavolino si rivela un arredo versatile e scultoreo, capace di bilanciare precisione e calore, perfetto per adattarsi alle due profondità delle sedute del sistema Riley.

The Stage side table, available in rectangular, square, or trapezoidal form, serves as a practical table top to be used between seats or as a sofa-side table, thanks to its bold geometric aesthetic. Designed by Hannes Peer, it features a supporting steel structure that holds two shelves with bevelled edges, available in wood or glossy lacquer. In the rectangular and square versions, Stage also features a variant with a sliding top that conceals a handy storage compartment. With its elegant line that evokes the shapes and colours of late 1970s Milanese design, this side table proves to be a versatile and sculptural furniture piece, capable of balancing precision and warmth, and serving as the perfect complement to the two depths of the Riley seating system.



BÉZIER COFFEE TABLE MARCIO KOGAN / STUDIO MK27

Le linee inedite e fluide del sistema di sedute Bézier, ispirate alla curva parametrica ideata dall'omonimo matematico francese, danno forma ad un coffee table organico ed irregolare. È disponibile con base in metallo verniciato bronzo lucido o ad effetto materico, con piano in marmo con bordo stondato o in essenza, il cui importante spessore dritto e non sagomato, nobilita il dialogo tra la materia lignea superiore e quella metallica inferiore.

I volumi irregolari e le linee sinuose che disegnano questo elemento da centro stanza abbracciano lo spazio e chi lo utilizza, dando vita a eleganti elementi d'arredo facilmente sovrapponibili tra loro grazie a diverse altezze.

The innovative, fluid lines of the Bézier seating system, inspired by the parametric curve devised by the French mathematician of the same name, give shape to an organic and irregular coffee table. It is available with a base in metal, varnished polished bronze colour or with a textured finish, and a top in either marble with a rounded edge or wood. The substantial, straight, unshaped thickness of the top highlights the dialogue between the wooden surface of the top and the metal base below.

The irregular volumes and sinuous lines that draws this room protagonist, embrace both the space and those who inhabit it, giving life to elegant furnishing pieces that can be easily overlapped together thanks to different heights.



NASTRO GIAMPIERO TAGLIAFERRI

Nastro è un side table dalle linee essenziali disponibile in due diverse misure e nella variante consolle. La sua struttura tridimensionale è costituita dall'intersezione di due sottili fasce metalliche rettangolari curvate che concorrono a farne un pezzo dal carattere spiccatamente scultoreo, perfetto per ospitare libri oppure oggetti. Ad esaltare la tridimensionalità dell'arredo, l'alternanza delle finiture lucide o opache che lo costituiscono. Si connota così un oggetto capace di integrarsi in ogni tipologia di ambiente living, esaltandone le prospettive grazie alle sue superfici riflettenti.

Nastro is a side table with essential lines, available in two different sizes and in a console version. Its three-dimensional structure is made up of the intersection of two thin, curved rectangular metal bands, which contribute to making it a piece with a distinctly sculptural character, perfect for holding books or objects.

The alternating use of the glossy or matte finishes that make up its structure enhance the three-dimensionality of the piece. It thus becomes a piece capable of blending seamlessly into any living space, boosting its perspectives thanks to its reflective surfaces.



CAMEO HANNES PEER

D'ispirazione modernista, nella linea pulita e nella scelta dei materiali, Cameo è un side table nato dalla combinazione di due semplici elementi, che formano un unicum scultoreo e funzionale il cui materiale riflette l'ambiente circostante. La slanciata base metallica a tronco piramidale sostiene il piano di appoggio che può agevolmente sovrapporsi alle sedute dei divani.

Cameo è proposto in un'unica dimensione in alluminio con finitura cromo Champagne, acciaio inox lucido oppure in metallo con satinatura profonda Brown.

Inspired by modernism, with its clean lines and thoughtful material choices, Cameo is a side table crafted from the combination of two simple elements, resulting in a sculptural and functional piece that reflects the surroundings. The sleek, pyramid-shaped metal base supports the tabletop, which can easily overlap the seats of the sofas.

Cameo is available in one unique dimension, in aluminium with a Champagne-colour chrome finish, in polished stainless steel or in painted metal with a deep Brown satin finish.



HELENE (UPDATE) HANNES PEER

Estremamente decorativo e scenografico, il tavolino Helene si contraddistingue per una struttura che nasce dall'incastro della base in acciaio inox lucido, di forma cilindrica o cubica, con il piano, rispettivamente rotondo o quadrato, disponibile in essenza ed ora anche laccato lucido nei colori Moka o Betulla. La base funge non solo da colonna portante, ma anche da funzionale vassoio contenitore al centro del piano, ideale per accompagnare i momenti di relax e di convivialità. Proposto in una sola altezza, Helene è in grado di trovare la sua centralità in ogni ambiente domestico, adattandosi a stili ed esigenze diverse.

Extremely decorative and scenic, the Helene coffee table stands out for its frame, which is created by the interlocking of a polished stainless steel base, in a cylindrical or cubic shape, with the top, round or square respectively, available in wood finishes and, now, also in the glossy lacquered Moka or Birch finishes. The base serves not only as a supporting element, but also as a functional storage tray, in the centre of the top, ideal for accompanying moments of relaxation and conviviality. Helene comes in one height and fits seamlessly into any home environment, adapting to different styles and needs.



TAIKO (UPDATE) NENDO

Progettato dallo studio Nendo, il tavolino Taiko è un'icona di ricercata semplicità, che si erge su una solida base realizzata in fusione di alluminio verniciato lucido color Bronzo o Black Coffee, a cui si aggiungono le nuove finiture Moka e Cappuccino, previste anche per il top di forma ovale. Taiko è ora proposto in tre diverse dimensioni, ideali per interpretare sia una classica situazione lounge che un moderno contesto dining informale.

Designed by the Nendo studio, the Taiko coffee table is an icon of refined simplicity, standing on a sturdy base crafted from die-cast aluminium in a glossy Bronze or Black Coffee varnished finish. The collection now includes the new finishes Moka and Cappuccino, available for both the base and the oval-shaped top. Taiko is now available in three different sizes, ideal for interpreting both a classic lounge situation and a modern, informal dining context.



FILL (UPDATE) HANNES PEER

Dalla famiglia di tavolini Fill, che si connotano come volumi monoblocco caratterizzati dalla totale assenza di spigoli, nascono anche l'omonimo comodino e il contenitore night. Gli arredi, previsti con cassetto esterno, che cela al suo interno un cassetto più piccolo portaoggetti, entrambi rivestiti in cuoio, sono disponibili laccati in svariate nuance cromatiche, tra cui l'inedito color Betulla. Le forme essenziali di Fill lo rendono un arredo scultoreo, grazie ai giochi di luce che si vengono a creare sulle superfici laccate e che ne moltiplicano i riflessi.

The Fill collection of coffee tables, distinguished by its monobloc volumes with a total absence of edges, is enhanced by the addition of the Fill nightstand and storage unit. Designed with an exterior drawer that conceals a smaller interior drawer for small items, both upholstered in saddle-hide, they are available with a lacquered finish in a variety of shades, including the original Birch colour. The bold, essential shapes of Fill make it a sculptural furnishing piece, accentuated by the interplays of light that form on the lacquered surfaces, multiplying reflections.



YVES SIDEBOARD HANNES PEER

Dalla declinazione del design dei piedini del sistema di sedute Yves, nasce la versione mobile contenitore. Un'elegante madia contemporanea, dall'apparente semplicità formale, proposta nelle versioni living e dining, in diverse dimensioni, ideale anche per vivere da protagonista a centro stanza. Si presenta con un disegno razionale e rigoroso, interpretato dall'allineamento dei piedini modanati con doppio torello, posti in corrispondenza delle fughe delle ante, che definiscono ritmicamente la composizione d'insieme.

Il piano incassato è realizzato in marmo, laccato o in essenza, mentre le ante e i fianchi laccati o in essenza sono impreziositi ai loro angoli da spigoli levigati con bordo stondato che ammorbidiscono il volume complessivo.

The feet of the Yves seating system are the inspiration behind the Yves storage unit. An elegant, contemporary sideboard characterized by an apparent formal simplicity, available in living and dining versions and various sizes, ideal for making a statement as the centrepiece of a room. It features a rational and precise design, expressed through the alignment of the double shaped rounded feet, positioned in line with the door joints, rhythmically defining the overall composition.

The recessed top is made of marble, lacquered or wood, while the corners of the lacquered or wooden doors and of the sides are enriched by smoothed edges and rounded borders, softening the overall volume.



LIBRA SIDEBOARD GIAMPIERO TAGLIAFERRI

Libra è il mobile contenitore dai volumi razionali e riflettenti ispirato all'omonima famiglia di coffee table e tavolo dining caratterizzati dallo stesso piede. Il top incassato in vetro retro verniciato negli stessi toni delle laccature lucide della struttura, aumenta l'effetto riflettente e tridimensionale dell'arredo. L'appoggio a terra è costituito da una base con piedi realizzati in tubolare e da una piastra metallica. Disponibile nelle versioni living e dining, questa famiglia di contenitori è concepita per integrarsi in svariate tipologie di ambienti per diventare un arredo classico senza tempo.

Libra is a storage unit with rational, reflective volumes, inspired by the eponymous family of coffee tables and dining tables, all characterised by the same foot design. The recessed top, in glass back-painted in the same shades as the glossy lacquered frame, enhances the reflective and three-dimensional effect of the furnishing piece, with the base featuring tubular feet and a metal plate.

Available in versions for living and dining spaces, this family of storage units is designed to elegantly complement various types of environments, becoming a timeless, classic design.



DIAGRAMMA SIDEBOARD GIAMPIERO TAGLIAFERRI

Dalla famiglia di tavolini Diagramma disegnata da Giampiero Tagliaferri nasce un mobile contenitore dalla forte estetica contemporanea. La sua forma irregolare e poliedrica lo connota come un volume scultoreo capace di diventare un elemento iconico dello spazio living. Tre lame in acciaio inox lucido curvato supportano l'intera struttura laccata lucida composta da cassetti e vano a giorno che rendono questo arredo anche estremamente funzionale. Elemento distintivo di questa serie di contenitori, la raffinata fascia metallica presente in corrispondenza dei due lati corti, che le conferisce un effetto scenico unico, perfetto per un posizionamento sia a parete che a centro stanza.

The Diagramma coffee table family designed by Giampiero Tagliaferri is joined by a storage unit with a strong contemporary aesthetic. Its irregular, multifaceted shape characterises it as a sculptural volume, capable of becoming an iconic element in the living space. Three curved polished stainless-steel blades support the entire glossy lacquered structure, which features drawers and an open compartment, also making this furnishing piece highly functional. A distinctive trait of this series of storage units is the refined metal band on both short sides, which gives it a unique dramatic effect, making it perfect when arranged either against a wall or as a centrepiece in the middle of the room.



SUPERBLOCKS (UPDATE) MARCIO KOGAN / STUDIO MK27

Superblocks è il progetto di Marcio Kogan / Studio MK27 ispirato al razionalismo di linee, forme, proporzioni e materiali tipico del lavoro dello studio brasiliano. Concepito come una vera e propria architettura, presenta un elemento contenitore laccato lucido o in essenza, proposto in diverse finiture e ora disponibile anche in noce Canaletto tinto Light Brown, che poggia su lame in metallo Brandy lucido. Un arredo non solo decorativo, ma anche funzionale, che si integra in diverse tipologie di ambienti grazie alle sue differenti versioni, night, living e dining: queste ultime due prevedono un elemento superiore in marmo, ora disponibile anche nella finitura Calacatta spazzolato.

Superblocks is the design by Marcio Kogan / Studio MK27 inspired by the rationalism of lines, shapes, proportions and materials typical of the Brazilian studio's work. Conceived as a true piece of architecture, it features a storage element in glossy lacquer or wood, available in different finishes and now also offered in Canaletto walnut stained Light Brown, resting on polished Brandy metal blades. A furnishing piece that is not only decorative, but also functional, integrating into various types of environments thanks to its different versions: night, living, and dining. The latter two feature a marble top element, now available in the brushed Calacatta finish.



ZOE (UPDATE) HANNES PEER

Una libreria dal chiaro sapore anni '70 declinato in un linguaggio contemporaneo: Zoe è composta da diverse forme geometriche replicate e affiancate tra loro in un armonioso gioco di strutture, che la trasformano in un vero e proprio sistema modulare, versatile e multifunzionale. L'elemento sagomato compare nella libreria come montante, in alluminio verniciato lucido – nei colori Bruciato, Moka e Muschio, a cui si aggiungono ora Cappuccino e Warm Grey – oppure verniciato Brown con satinatura profonda, anch'esso introdotto con la 2025 Collection, posto in corrispondenza dei piani in essenza o laccati nelle medesime finiture previste per i fianchi. Un incastro raffinato che unisce materiali diversi, donando una forte identità decorativa e creando un inedito alternarsi di spazi vuoti e pieni.

A bookcase with a clear '70s influence expressed in a contemporary language: Zoe is a design composed of various geometric shapes, replicated and placed side by side in a harmonious interplay of structures, transforming it into a true versatile and multifunctional modular system. The contoured element appears in the bookshelf as a vertical support, in glossy varnished aluminium—in the colours Burnt Brown, Moka, and Moss, now joined by Cappuccino, Terracotta, and Warm Grey—or in a Brown lacquered version with a deep satin finish, also introduced with the 2025 Collection, positioned alongside the wooden shelves, available in the same finishes as the side panels. A refined interlocking design that blends different materials, creating a strong decorative identity and a unique alternation of empty and full spaces.



LIBRA TABLE GIAMPIERO TAGLIAFERRI

Libra è un tavolo dalla linea spiccatamente modernista, la cui realizzazione richiede sofisticate tecniche costruttive. Nella versione rettangolare, il top in marmo, pietra o essenza si presenta con una sezione a “C” rovesciata, impreziosita alle estremità dei lati corti da una fascia arretrata in metallo cromato. La versione tonda, invece, presenta un top dal bordo sagomato stondato;che può essere arricchito da un elemento vassoio girevole nelle medesime finiture del piano, quale elemento di servizio o puramente decorativo. Le gambe sono costituite da piastre in metallo o essenza piegate a “V”, in abbinamento alle basi tubolari, di chiaro rimando all'estetica di quelle della famiglia di sedute Libra.

Libra is a table with a distinctly modernist line, crafted with sophisticated construction techniques. In the rectangular version, the top – available in marble, stone, or wood –features an inverted “C” section, embellished at the ends of the short sides by a recessed band in chrome-plated metal. The round version, on the other hand, features a top with a rounded contoured edge which can be enriched by a revolving tray element available in the same finish as the top, and can be added as a service feature or a purely decorative element. The legs are made of metal or wood plates bent into a “V” shape, paired with the tubular bases that clearly reference the aesthetic of the Libra family of seats.



LINHA LIVRE MARCIO KOGAN / STUDIO MK27

Il tavolo dining Linha, manifesto della costante ricerca dell'eleganza nelle proporzioni e dell'attenzione per i dettagli da parte dello Studio MK27, si declina nella sua forma più segmentata trasformando il piano rettangolare in una dinamica forma poligonale. Le sottili gambe portanti in metallo bronzo patinato sorreggono il piano in pietra, marmo o in essenza, rispondendo alla sfida progettuale di un tavolo dining con una grande campata, una struttura dallo spessore sottile e un top che arriva ai 4 metri di lunghezza. Linha Livre, grazie alla sua inusuale conformazione, è la versione a forma più libera che permette alle sedute di ricreare una geometria avvolgente e senza gerarchie attorno al tavolo.

The Linha dining table, a manifesto of Studio MK27's constant pursuit of elegance in proportions and attention to detail, takes on its most segmented form, transforming the rectangular top into a dynamic polygonal shape. Its slender legs in patinated bronze metal support the top in stone, marble or wood, meeting the design challenge of a dining table with a large span, a thin frame, and a top that spans up to 4 metres in length. With its unique shape, Linha Livre is the more free-form version, allowing the seats to compose a convivial, hierarchy-free arrangement around the table.



SAKI TABLE NENDO

La scultorea base in finitura laccata lucida di questo tavolo lo rende un oggetto dalla forte identità, facilmente riconducibile al sinuoso design della famiglia di sedute Saki. Il piano in appoggio di forma quadrata e rettangolare con perimetro e angoli stondati è disponibile in svariate misure, a sbalzo e bordato con un toreello stondato, che ne enfatizza la tridimensionalità spaziale. Declinato anche nell'ampia versione rettangolare presenta in tal caso una doppia gamba di appoggio, posizionata in corrispondenza dei punti focali del piano.

The sculptural base with glossy lacquered finish gives this table a strong identity, recalling the sinuous design of the Saki family of seats. The square and rectangular tabletop, with rounded perimeter and corners, is available in various sizes. It features a cantilevered design with a rounded double edge, enhancing its spatial three-dimensionality. Also available in a large rectangular version, it features a double supporting leg positioned at the focal points of the top.



LIBRA BED GIAMPIERO TAGLIAFERRI

L'ispirazione all'estetica anni '70 che contraddistingue le sedute Libra caratterizza anche Libra Bed, il progetto per la zona notte in cui si ritrova la medesima sovrapposizione di volumi tondeggianti di seduta, schienale e poggiatesta e i meticolosi dettagli sartoriali che contraddistinguono le imbottiture valorizzandone la ricercata lavorazione artigianale. Caratteristiche distintive di questo letto - la cui base che accoglie il materasso è costituita da un sommier a molle - sono il profilo che scandisce le arricciature lungo il perimetro, rendendolo particolarmente soffice, nonché i piedini realizzati con tubolari metallici. Libra è anche un elegante copriletto in satin di misto lana pettinata. Confezionato interamente a mano ed impreziosito da un raffinato effetto mélange che esalta le caratteristiche naturali del filato, è rifinito da un bordo perimetrale di 6 cm realizzato nel medesimo tessuto e cromia scelti per il copriletto.

The 1970s aesthetic inspiration that distinguishes the Libra seats also defines Libra Bed, the design for the night area, where the same overlapping rounded volumes of the seat, backrest and headrest are found, along with the meticulous tailoring details that characterise the upholstery and highlight the refined artisanal craftsmanship. Distinctive features of this bed – whose base supporting the mattress consists of a spring sommier – are the profile that outlines the curling along the perimeter, making it particularly soft, as well as the feet made from chrome-plated metal tubes. Libra is an elegant bedspread, made of a satin blend of combed wool. Entirely handcrafted and embellished with a refined mélange effect that highlights the natural qualities of the yarn, it is finished with a 6 cm perimeter border made from the same fabric and colour chosen for the bedspread.



ZEALAND MINOTTI STUDIO

Il tappeto Zealand in pregiata lana dalla Nuova Zelanda, interamente prodotto a mano con metodo hand woven, esalta nella sua estetica le caratteristiche della tecnica di tessitura e del materiale col quale è realizzato. L'uso di filati naturali spessi e preziosi dà vita a un tappeto durevole e dalla significativa qualità tecnica, caratterizzato da un'elegante texture tridimensionale e da un effetto mélange marcato. Contraddistinto da un manto superficiale dello spessore di 15 mm e da un sottofondo perimetrale costituito da un nastro jacquard in cotone rigenerato, questo complemento combina tradizione e modernità, aggiungendo un tocco morbido e contemporaneo di grande eleganza.

The Zealand rug, made from fine wool from New Zealand and entirely hand-woven, sports an aesthetic that enhances both the qualities of the weaving technique and the material used. The use of exquisite, thick, natural yarns brings to life a durable rug of significant technical quality, characterized by an elegant three-dimensional texture and a pronounced mélange effect.

Distinguished by a 15 mm thick surface pile and a perimeter backing made of a jacquard ribbon in regenerated cotton, this piece blends tradition and modernity, adding a soft, contemporary touch of grand elegance.



FAIRWAY MINOTTI STUDIO

L'importante profondità del vello del tappeto Fairway è ottenuta lavorando manualmente cashmere e lana per garantire un velluto straordinariamente spesso e prezioso, ricco di personalità artigianale. L'altezza del tessuto conferisce a questo tappeto particolare tridimensionalità e una capacità di cambiare aspetto grazie al rinfingersi della luce sulla sua superficie; tale morbidezza lo rende molto gradevole anche per la consistenza e l'estrema piacevolezza al calpestio. La notevole morbidezza, la sottile lucentezza e il richiamo estetico alle atmosfere Seventies, unite alla classe d'uso 33, che certifica l'idoneità in contesti commerciali caratterizzati da un calpestio inteso, e la classificazione antincendio BFL, fanno del tappeto Fairway la scelta perfetta per caratterizzare i più diversi interni residenziali e Hospitality.

The significant depth of the Fairway rug pile is achieved by manually processing cashmere and wool to ensure an extraordinarily thick and precious velvet, rich in artisanal personality. The height of the fabric gives this rug a unique three-dimensionality and the ability to change its appearance as light reflects off its surface; this softness enhances its appeal, due both to its texture and the exceptional pleasure it offers underfoot.

The remarkable softness, subtle sheen and aesthetic reference to Seventies atmospheres, combined with class 33 certification, which certifies suitability for commercial spaces with heavy foot traffic, and fire classification BFL, make the Fairway rug the perfect choice to define a wide range of residential and hospitality interiors.



ALPS (UPDATE) MINOTTI STUDIO

Un tappeto di grande eleganza, dal manto morbido, Alps trasmette intimità e calore agli interni. Realizzato a mano nel pieno rispetto della confezione da pellicceria, è ottenuto assemblando tra loro pelli di montone provenienti dalla Nuova Zelanda, selezionate e accuratamente conciate per rispondere ai più alti standard qualitativi. Il manto è estremamente resistente e tenace, antistatico e fonoassorbente. Personalizzato sul retro con un'elegante tessuto jacquard con logo Minotti, garantisce una funzione antiscivolo grazie a un tessuto tecnico di cotone stampato con microparticelle di silicone disposte lungo i bordi. Realizzabile anche su misura, Alps è proposto nelle nuance Malachite, Ferro, Argento, Moka, Nero, Cashmere e Desert, a cui si aggiunge il nuovo colore Muschio.

A rug of great elegance with a soft pile, Alps brings warmth and a sense of intimacy to interior spaces. Made by hand with the utmost respect for traditional leather crafting techniques, it is created by assembling sheepskins from New Zealand, carefully selected and tanned to meet the highest quality standards. The pile is highly durable and resilient, antistatic, and sound-absorbing. Personalised on the back with an elegant jacquard fabric featuring the Minotti logo, it has guaranteed anti-slip properties courtesy of the printed cotton technical fabric with silicone micro-particles arranged along the edges. Also available in custom sizes, the Alps colour palette offers shades of Malachite, Ferro, Argento, Moka, Nero, Cashmere e Desert, now joined by the new colour Muschio.



BÉZIER CORD OUTDOOR MARCIO KOGAN / STUDIO MK27

Con i suoi volumi avvolgenti, il sistema di sedute Bézier Cord Outdoor disegna nuovi landscapes open-air attraverso configurazioni originali e inaspettate. Progettato dallo Studio MK27 ed ispirato dalla geometria della curva parametrica del matematico Bézier, matrice dell'omonima versione indoor, questo sistema esplora un inedito linguaggio compositivo di grande impatto: caratterizzato da volumi irregolari dall'estetica dinamica e da linee sinuose che avvolgono lo spazio, possono essere utilizzati in aggregazione tra loro o come elementi singoli, instaurando un dialogo intimo ed armonico con chi lo vive.

Bézier Cord Outdoor si connota con una struttura dello schienale in tubolare di alluminio verniciato, avvolto longitudinalmente da un intreccio di corda in polipropilene dal forte spessore, e rifinito alle estremità da una piastra in alluminio verniciata in nuance con la corda.

La seduta monoblocco estremamente confortevole è caratterizzata da una morbidezza ottenuta grazie all'attenta stratificazione di poliuretani a quote differenziate ad alta densità che conferiscono un comfort omogeneo su tutta la superficie. Trattandosi di forme organiche, la lavorazione sartoriale delle cuciture è estremamente puntuale, seguendo meticolosamente le sinuosità degli elementi. La seduta profonda e generosa è sollevata da terra grazie a piedini arretrati in acciaio inox verniciati in tonalità testa di moro, rendendo questo sistema ideale tanto per contesti formali quanto per momenti di puro relax.

Characterized by enveloping volumes, the Bézier Cord Outdoor seating system designs new open-air landscapes through original and unexpected configurations. Designed by Studio MK27 and inspired by the geometry of the parametric curve of the mathematician Bézier, which is the matrix of its indoor counterpart, this system explores a unique, powerful compositional language: characterised by irregular volumes, dynamic aesthetic and sinuous lines that embrace the space, the elements can be used together in various combinations or as standalone pieces, establishing an intimate and harmonious dialogue with those who experience them.

Bézier Cord Outdoor features a painted tubular aluminium backrest structure, wrapped longitudinally in a thick polypropylene cord weave, and finished at the ends with an aluminium plate in a nuance that matches the cord.

The exceptionally comfortable one-piece seat is defined by its softness, achieved as a result of the careful layering of high-density polyurethane foams with varying thicknesses, ensuring uniform comfort across the entire surface. Given the organic shapes, the tailoring of the stitching is extremely precise, meticulously following the curves of each element. The deep and generous seat is elevated off the ground thanks to the recessed stainless steel feet in dark brown, making Bézier Cord Outdoor ideal for both formal settings and moments of pure relaxation.



SAKI OUTDOOR - SAKI CORD OUTDOOR NENDO

La versione per gli spazi open-air dell'organico sistema di sedute indoor Saki progettato da Nendo è prevista nelle declinazioni con sinuosi pannelli laccati, Saki Outdoor, oppure con pannelli caratterizzati da un intreccio incordato ad effetto midollino, Saki Cord Outdoor: entrambe le famiglie di sedute sono disponibili in un'ampia varietà di finiture che consentono di ottenere svariate combinazioni, conferendo così agli arredi un'estetica sofisticata e dalla forte personalità.

Con la forma sinuosa dei pannelli di schienali e braccioli, Nendo richiama l'immagine della fioritura, in giapponese Saki, da cui prende il nome questo sistema. La seduta morbida offre un comfort estremo, ulteriormente enfatizzato da avvolgenti cuscini schienale, delicatamente appoggiati sulle pannellature a petalo.

Anche la versione outdoor, perfettamente coerente al concept di aggregabilità, dispone delle varianti divano a 2, 3 o 4 posti, elementi con due diverse profondità, poltrona con e senza braccioli, panche ed originali isole particolarmente accoglienti disponibili in diverse configurazioni, previste sia con piedi fissi curvilinei che con base girevole.

Il sistema presenta sedute generose dalla silhouette morbida e arrotondata, rifinite da un piping perimetrale che ne disegna elegantemente i volumi. Il dettaglio sartoriale praticato sulla parte superiore della cuscinatura angolare scandisce i profili degli imbottiti, creando una separazione e una coesione ben equilibrate. Anche i piedi curvilinei in pressofusione di alluminio verniciato peltro si adeguano perfettamente all'estetica avvolgente e sinuosa.

The open air version of the organic Saki indoor seating system, designed by Nendo, is available with sleek lacquered panels, Saki Outdoor, or with panels featuring a wicker-effect woven cord design, Saki Cord Outdoor: both seating families offer a wide variety of finishes, and can be combined to give the furnishing pieces a sophisticated aesthetic and a strong personality.

Thanks to the sinuous shape of the backrest and armrest panels, Nendo evokes the image of blooming flowers, or “Saki” in Japanese, from which the system takes its name. The soft seat offers extreme comfort, further emphasised by enveloping back cushions, gently resting on the petal-shaped panels.

The outdoor version, perfectly consistent with the concept of modularity, offers 2, 3, or 4-seat sofa variants, elements in two different depths, armchairs with and without armrests, benches and original, particularly cosy islands conceived in different configurations, both presenting fixed curved feet or swivel bases.

The system features generous seating with a soft, rounded silhouette, finished with a perimeter piping that elegantly defines its volumes. The tailoring detail on the top of the corner cushion accentuates the profiles of the upholstery, creating a well-balanced separation and cohesion. The curved feet, in die-cast aluminium, pewter varnished, perfectly complement the enfolding and sinuous aesthetic.



EMMI CORD OUTDOOR HANNES PEER

Progettata da Hannes Peer per l'indoor, Emmi si declina anche per il living all'aperto dando vita ad una poltrona e ad un divano che richiamano l'elegante estetica degli arredi outdoor anni '70, con forme ampie e accoglienti.

Realizzata per vivere nei più svariati contesti outdoor, l'esile struttura metallica in tubolare rivestita con intreccio in corda nella medesima nuance, ospita i morbidi cuscini di seduta e schienale. La sua base, dall'originale silhouette sinuosa, disegna come una linea continua la seduta e lo schienale, donando all'arredo una sofisticata leggerezza visiva che lo rende più aereo.

Designed by Hannes Peer for indoor spaces, Emmi is also adapted for open-air living, giving rise to an armchair and a sofa that evoke the elegant aesthetic of 1970s outdoor furnishing pieces, with generous and inviting shapes.

Created to thrive in a wide variety of settings, the slender tubular metal frame, covered with woven cord in the same colour, supports the soft seat and back cushions. Its base, with its original sinuous silhouette, draws a continuous line between the seat and backrest, giving the furnishing piece a sophisticated visual lightness that makes it feel more weightless.



ANDRÉE DINING OUTDOOR HANNES PEER

Di chiara ispirazione anni '70, Andrée Dining Outdoor riprende gli stilemi costruttivi dell'omonimo tavolino disegnato da Hannes Peer che, grazie alle caratteristiche di grande resistenza e durezza del suo materiale, risulta particolarmente adatto agli ambienti open-air.

Oltre alla sua rigorosa geometria, la texture della piastrella in ceramica smaltata, che lo riveste interamente, rende questo arredo unico, mai uguale a se stesso. Questo tavolo è composto da due gambe verticali, che sorreggono l'ampio piano rettangolare. Il monocromo e monomaterico che caratterizza Andrée Dining Outdoor lo rende un progetto timeless ed estremamente fruibile, facilmente adattabile per diversi contesti da quelli domestici a quelli Hospitality.

Clearly inspired by the 1970s, Andrée Dining Outdoor picks up on the design elements of the homonymous coffee table by Hannes Peer, which, thanks to the high resistance and durability of its material, is particularly suitable for open-air environments.

In addition to its rigorous geometry, the texture of the glazed ceramic tile that fully covers it, defines this piece of furniture as unique and never the same twice. This table consists of two vertical legs, which support the large rectangular top. The monochrome, single-material design of Andrée Dining Outdoor makes it a timeless project, highly versatile and easily adaptable to a variety of settings, from domestic spaces to Hospitality environments.



ANDRÉE OUTDOOR HANNES PEER

La versione per gli ambienti open-air dei tavolini Andrée progettati da Hannes Peer, ispirati alle architetture milanesi anni '70, ha come segno distintivo la matericità della piastrella in ceramica smaltata, disponibile in svariate nuance, perfettamente in linea con le cromie tipicamente Seventies. Andrée Outdoor si propone con piedi in alluminio verniciato bronzo e in varie dimensioni per i top; tutte le facce del tavolino sono interamente piastrellate e caratterizzate da una stuccatura lungo le fughe delle piastrelle, dettaglio che rende questa tipologia di tavolini particolarmente idonea agli ambienti outdoor; la versione a prisma, invece, presenta un piano d'appoggio in alluminio verniciato in color testa di moro.

The outdoor version of the Andrée coffee tables, designed by Hannes Peer and inspired by 1970s Milanese architecture, is characterised by the tactile quality of the glazed ceramic tile, available in various nuances that perfectly reflect the typical Seventies colour palette. Andrée Outdoor comes with bronze-painted aluminium feet and offers a various dimensions for the tops. All sides of the coffee table are fully tiled and characterised by grouting along the tile joints—a detail that makes this style particularly well-suited for outdoor environments. The prism version, on the other hand, features a dark brown painted aluminium top.



BÉZIER OUTDOOR MARCIO KOGAN / STUDIO MK27

Una famiglia di tavolini dalle forme fluide e inusuali, progettate dallo Studio MK27 seguendo le geometrie della curva parametrica di Bézier. La struttura centrale in acciaio inox sorregge il piano in marmo o pietra dalla bordatura arrotondata. I volumi organici e la silhouette curvilinea rendono questi tavolini outdoor molto versatili, facilmente sovrapponibili tra loro ed abbinabili ad arredi di stili diversi.

A family of coffee tables with fluid and unusual shapes, designed by Studio MK27, following the geometries of the Bézier parametric curve. The central stainless steel frame supports the marble or stone top with rounded edges. The organic volumes and curvilinear silhouette make these outdoor coffee tables highly versatile, easy to overlap each other and combinable with furnishings of different styles.



TAIKO OUTDOOR (UPDATE) NENDO

La declinazione outdoor del tavolino Taiko progettato per l'indoor porta con sé le medesime caratteristiche di ricercata semplicità. Il top di forma ovale, realizzato in fusione di alluminio verniciato lucido color Bronzo o nelle nuove finiture Moka e Cappuccino, è disponibile anche opaco nei colori Écru e Testa di Moro, ed è sorretto da una base in fusione di alluminio verniciato in continuità cromatica con il top. Taiko Outdoor è ora proposto in tre diverse dimensioni, ideali per trovare la loro ideale collocazione in ogni ambiente open-air.

The outdoor version of the Taiko coffee table designed for indoor use brings with it the same characteristics of refined simplicity. The oval-shaped top, crafted from cast aluminium with a glossy finish in Bronze or the new Moka and Cappuccino shades, is also available in a matte version in Ecru and Dark Brown. It is supported by a die-cast aluminium base, seamlessly finished in the same colour as the top. Taiko Outdoor is now available in three different sizes, perfect for finding the ideal placement in any open-air space.

10/11 - 12/13 - 14/15 - 17

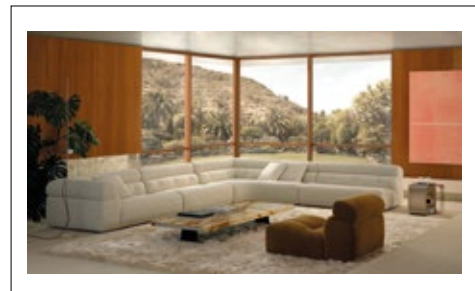

COMPOSITION DIMENSIONS CM 476X353
COUPÉ ELEMENT WITH 1 ARMREST SX CM 179X109 H68
COUPÉ CENTRAL ELEMENTS CM 146X109 H68
COUPÉ CORNER SOFA SX CM 207X151 H68
 FABRIC: MONTEREY 03 SABBIA (ART 43)
 BASE: VARNISHED POLISHED BIRCH GREY COLOUR ALUMINIUM
COUPÉ CENTRAL ELEMENT CM 90X109 H68
 LEATHER: BIG SUR 05 CURRY (BIG SUR - CARMEL LEATHER)
 BASE: BRUSHED POLISHED ALUMINIUM

LIBRA COFFEE TABLE CM 220X80 H28
 TOP: GIALLO SIENA MARBLE

NASTRQ SIDE TABLE CM 55X50 H45
 EXTERNAL STRUCTURE: SATIN / POLISHED STAINLESS STEEL
 INTERNAL STRUCTURE: VARNISHED POLISHED BIRCH GREY COLOUR METAL

PILOTIS SIDE TABLE Ø CM 27 H45
 STRUCTURE: POLISHED STAINLESS STEEL

ALPS RUG CM 450X350 / CASHMERE COLOUR

44/45

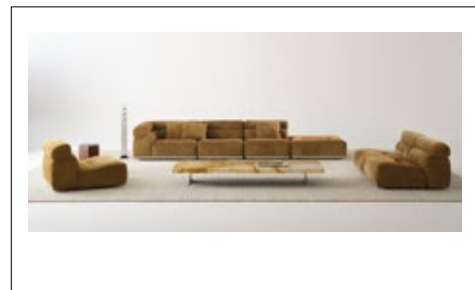

COMPOSITION DIMENSIONS CM 412X109
COUPÉ ELEMENT WITH 1 ARMREST SX CM 123X109 H68
COUPÉ CENTRAL ELEMENTS CM 90X109 H68
COUPÉ OTTOMAN CM 109X109 H39
 LEATHER: BIG SUR 05 CURRY (BIG SUR - CARMEL LEATHER)
 BASE: BRUSHED POLISHED ALUMINIUM

LIBRA COFFEE TABLE CM 220X80 H28
 TOP: GIALLO SIENA MARBLE

ANDRÉE SIDE TABLE CM 36X31 H48,5
 STRUCTURE COVER: GLAZED CORTEN COLOUR CERAMIC
 PLATES: POLISHED CHROME BRASS

ZEALAND RUG CM 700X500 / ASH COLOUR - SPECIAL SIZE

64/65

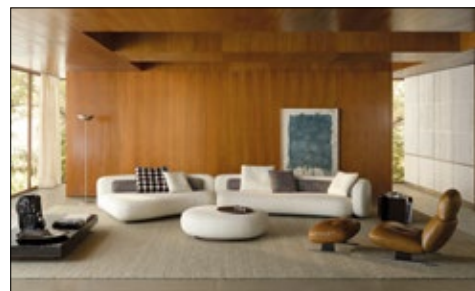

COMPOSITION DIMENSIONS CM 491X188
BÉZIER CENTRAL ELEMENT SX CM 220X188 H84 - DOUBLE DEPTH
BÉZIER ELEMENT WITH 1 ARMREST DX CM 271X155 H79
BÉZIER OTTOMAN CM 129X114 H41
 FABRIC: MONTEREY 02 ECRU (ART 43)
BÉZIER CUSHIONS
 FABRIC: PRASLIN BIG 06 CIOCCOLATO (ART 42)
 FABRIC: PRASLIN SMALL 06 CIOCCOLATO (ART 42)

LIBRA BERGÈRE CM 78X98 H82
LIBRA FOOTSTOOL CM 78X57 H37
 LEATHER: CARMEL 02 TANGANICA (BIG SUR - CARMEL LEATHER)
 LEGS: VARNISHED MATT BLACK COLOUR METAL
 CYLINDRICAL BARS: POLISHED CHROME METAL

ANDRÉE COFFEE TABLE CM 215X93 H24
 STRUCTURE COVER: GLAZED BLACK COLOUR CERAMIC

ZEALAND RUG CM 700X500 / ASH COLOUR - SPECIAL SIZE

10/11 - 18/19 - 20 - 21

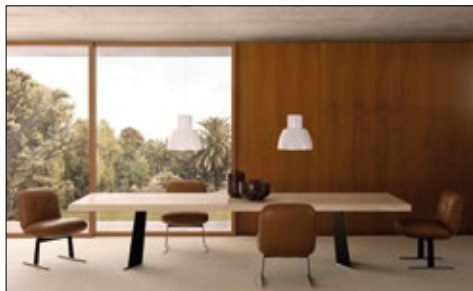

LIBRA DINING LITTLE ARMCHAIRS CM 55X70 H82
 LEATHER: CARMEL 02 TANGANICA (BIG SUR - CARMEL LEATHER)
 LEGS: VARNISHED MATT BLACK COLOUR METAL
 CYLINDRICAL BARS: POLISHED CHROME METAL

LIBRA DINING TABLE CM 350X110 H74
 TOP: TRAVERTINE STONE
 LEGS: VARNISHED MATT BLACK COLOUR METAL
 CYLINDRICAL BARS: POLISHED CHROME METAL

46/47

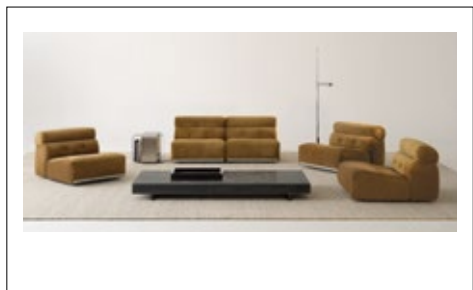

COUPÉ CENTRAL ELEMENTS CM 90X109 H68
 LEATHER: BIG SUR 05 CURRY (BIG SUR - CARMEL LEATHER)
 BASE: BRUSHED POLISHED ALUMINIUM

ANDRÉE COFFEE TABLE CM 215X93 H24
 STRUCTURE COVER: GLAZED BLACK COLOUR CERAMIC

NASTRQ SIDE TABLE CM 55X50 H45
 EXTERNAL STRUCTURE: SATIN / POLISHED STAINLESS STEEL
 INTERNAL STRUCTURE: VARNISHED POLISHED BIRCH GREY COLOUR METAL

ZEALAND RUG CM 700X500 / ASH COLOUR - SPECIAL SIZE

66/67 - 68/69

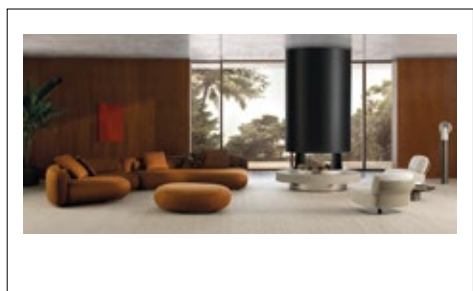

COMPOSITION DIMENSIONS CM 502X228
BÉZIER CHAISE-LONGUE SX CM 228X228 H84
BÉZIER CENTRAL ELEMENT DX CM 274X224 H84 - DOUBLE DEPTH
 FABRIC: TRINITY 06 TANGANICA (ART 42)
BÉZIER CUSHIONS
 LEATHER: PONY LOOK NATURAL COW (SPECIAL LEATHER)

BÉZIER OTTOMAN CM 140X131 H41
 LEATHER: BIG SUR 04 CANNELLA (BIG SUR - CARMEL LEATHER)

SAKI ARMCHAIRS WITHOUT ARMRESTS WITH BASE CM 80X92 H66
 FABRIC: MONTEREY 03 SABBIA (ART 43)
 SUPPORT PANELS: GLOSSY CAPPUCCINO COLOUR LACQUERED

ANDRÉE SIDE TABLE CM 36X31 H48,5
 STRUCTURE COVER: GLAZED CORTEN COLOUR CERAMIC
 PLATES: POLISHED CHROME BRASS

22/23 - 24 - 25

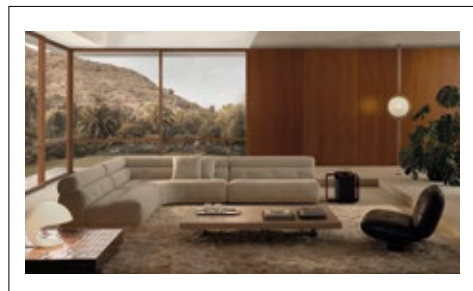

COMPOSITION DIMENSIONS CM 297X353
COUPÉ CENTRAL ELEMENTS CM 146X109 H68
COUPÉ CORNER SOFA SX CM 207X151 H68
 FABRIC: MONTEREY 03 SABBIA (ART 43)
 BASE: VARNISHED POLISHED BIRCH GREY COLOUR ALUMINIUM
LIBRA ARMCHAIR CM 76X86 H70
 LEATHER: CARMEL 03 EBANO (BIG SUR - CARMEL LEATHER)
 LEGS: VARNISHED MATT BLACK COLOUR METAL
 CYLINDRICAL BARS: POLISHED CHROME METAL

LIBRA COFFEE TABLE CM 175X110 H28
 TOP: TRAVERTINE STONE

ANDRÉE COFFEE TABLE CM 120X116,5 H24
 STRUCTURE COVER: GLAZED CORTEN COLOUR CERAMIC

NASTRQ SIDE TABLE CM 55X50 H45
 EXTERNAL STRUCTURE: DEEP SATIN BROWN COLOUR METAL /
 VARNISHED POLISHED BURNT BROWN COLOUR METAL
 INTERNAL STRUCTURE: VARNISHED POLISHED BURNT BROWN METAL

48/49



COUPÉ CENTRAL ELEMENTS CM 90X109 H68
COUPÉ OTTOMAN CM 109X109 H39
COUPÉ CORNER SOFA DX CM 179X151 H68
 LEATHER: BIG SUR 05 CURRY (BIG SUR - CARMEL LEATHER)
 BASE: BRUSHED POLISHED ALUMINIUM

NASTRQ SIDE TABLE CM 55X50 H45
 EXTERNAL STRUCTURE: SATIN / POLISHED STAINLESS STEEL
 INTERNAL STRUCTURE: VARNISHED POLISHED BIRCH GREY
 COLOUR METAL

LIBRA COFFEE TABLE CM 220X80 H28
 TOP: GIALLO SIENA MARBLE

68/69 - 70 - 71

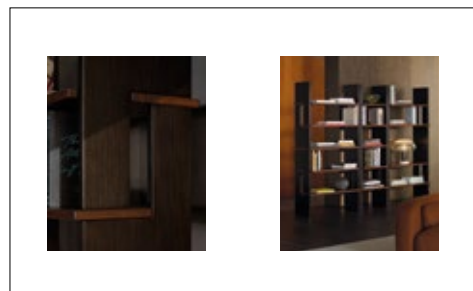

ZOE BOOKCASE CM 100X46 H208 - MOD. A
ZOE BOOKCASE CM 60X46 H208 - MOD. A
ZOE BOOKCASE CM 100X46 H208 - MOD. B
 SIDES: DEEP SATIN BROWN COLOUR METAL
 SHELVES: LIGHT BROWN STAINED CANALETTO WALNUT

26/27 - 28/29

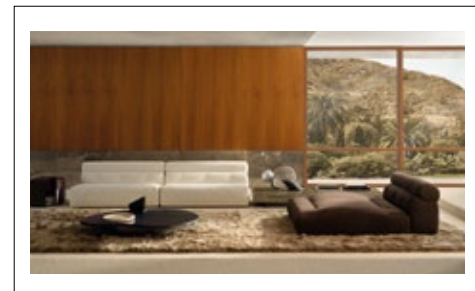

COUPÉ COUCH CM 146X179 H68
 LEATHER: BIG SUR 03 CACAO (BIG SUR - CARMEL LEATHER)
 BASE: VARNISHED POLISHED BLACK COFFEE COLOUR ALUMINIUM

COUPÉ CENTRAL ELEMENTS CM 146X109 H68
 FABRIC: MONTEREY 03 SABBIA (ART 43)
 BASE: VARNISHED POLISHED BIRCH GREY COLOUR ALUMINIUM

ANDRÉE COFFEE TABLE CM 215X93 H24
 STRUCTURE COVER: GLAZED PUTTY COLOUR CERAMIC

BÉZIER COFFEE TABLE CM 143X138 H20
 TOP: PIERRE BLEUE STONE
 BASE: VARNISHED POLISHED BRONZE COLOUR METAL

NASTRQ SIDE TABLE CM 55X50 H45
 EXTERNAL STRUCTURE: DEEP SATIN BROWN COLOUR METAL /
 VARNISHED POLISHED BURNT BROWN COLOUR METAL
 INTERNAL STRUCTURE: VARNISHED POLISHED BURNT BROWN COLOUR METAL

ALPS RUGS CM 450X250 / DESERT COLOUR - SPECIAL SIZE

50/51 - 52/53



LIBRA BED BED CM 212X246 H102
 FABRIC: TRINITY 02 NATURALE (ART 42)
 LINEN SHEET: ECRU COLOUR
LIBRA BED BENCH CM 192X52 H37
 LEATHER: BIG SUR 02 TORTORA (BIG SUR - CARMEL LEATHER)
 BASES AND CYLINDRICAL BARS: VARNISHED POLISHED BLACK COFFEE COLOUR METAL
LIBRA THROW CM 240X200
LIBRA BEDSPREAD CM 270X270

FILL SIDE TABLE CM 35X35 H43
 STRUCTURE: GLOSSY MOKA COLOUR LACQUERED

VIVIENNE LOUNGE SOFAS CM 212X100 H80
 LEATHER: BIG SUR 04 CANNELLA (BIG SUR - CARMEL LEATHER)
 BASES: VARNISHED POLISHED BLACK COFFEE COLOUR ALUMINIUM

72/73 - 74/75 - 77 - 78/79 - 81 - 82/83

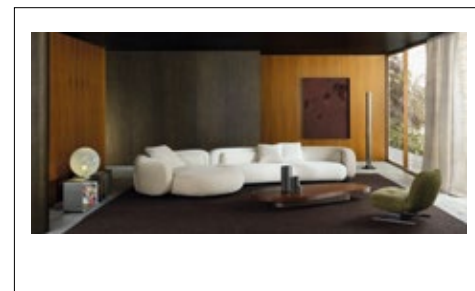

COMPOSITION DIMENSIONS CM 441X210
BÉZIER CHAISE-LONGUE SX CM 190X210 H84
BÉZIER ELEMENT WITH 1 ARMREST DX CM 271X155 H79
 FABRIC: MONTEREY 05 CORDA (ART 43)

LIBRA ARMCHAIR CM 76X86 H70
 LEATHER: BIG SUR 06 OLIVA (BIG SUR - CARMEL LEATHER)
 LEGS: VARNISHED MATT BLACK COLOUR METAL
 CYLINDRICAL BARS: POLISHED CHROME METAL

BÉZIER COFFEE TABLE CM 206X101 H20
 TOP: LIGHT BROWN STAINED CANALETTO WALNUT
 BASE: TEXTURED BRONZE COLOUR METAL

NASTRQ CONSOLE TABLE CM 160X40 H46,5
 EXTERNAL STRUCTURE: SATIN / POLISHED STAINLESS STEEL
 INTERNAL STRUCTURE: VARNISHED POLISHED BIRCH GREY COLOUR METAL

ZEALAND RUG CM 700X500 / MOKA COLOUR - SPECIAL SIZE

30/31 - 33 - 34 - 35 - 36/37 - 38 - 39



COMPOSITION DIMENSIONS CM 414X109
COUPÉ ELEMENT WITH 1 ARMREST SX CM 179X109 H68
COUPÉ ELEMENT WITH 1 ARMREST DX CM 235X109 H68
 LEATHER: BIG SUR 01 AVORIO (BIG SUR - CARMEL LEATHER)
 BASE: BRUSHED POLISHED ALUMINIUM

LIBRA BERGÈRE CM 78X98 H82
LIBRA FOOTSTOOL CM 78X57 H37
 LEATHER: CARMEL 02 TANGANICA (BIG SUR - CARMEL LEATHER)
 LEGS: VARNISHED MATT BLACK COLOUR METAL
 CYLINDRICAL BARS: POLISHED CHROME METAL

ANDRÉE COFFEE TABLE CM 215X93 H24
 STRUCTURE COVER: GLAZED BLACK COLOUR CERAMIC

ANDRÉE SIDE TABLE CM 35,5X21 H48,5
 STRUCTURE COVER: ASH LICORICE COLOUR LACQUER
 PLATES: POLISHED CHROME BRASS

ZEALAND RUG CM 700X500 / SAGE COLOUR - SPECIAL SIZE

54/55

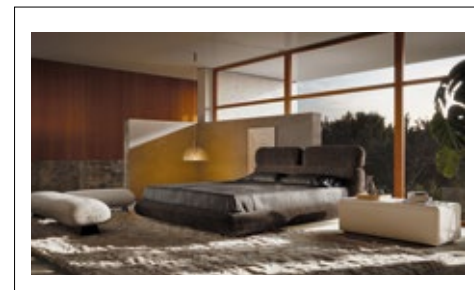

LIBRA BED BED CM 212X246 H102
 LEATHER: BIG SUR 03 CACAO (BIG SUR - CARMEL LEATHER)
LIBRA BENCH DX CM 192X152 H37
 FABRIC: MONTEREY 02 ECRU (ART 43)
 LEGS: VARNISHED MATT BLACK COLOUR METAL
 CYLINDRICAL BARS: POLISHED CHROME METAL

FILL NIGHT SIDEBOARD CM 120X55 H40
 STRUCTURE: GLOSSY BIRCH GREY COLOUR LACQUERED

LIBRA COFFEE TABLE CM 130X130 H28
 TOP: LIGHT BROWN STAINED CANALETTO WALNUT

ALPS RUG CM 600X250 / CASHMERE COLOUR - SPECIAL SIZE

84/85 - 87 - 88 - 89

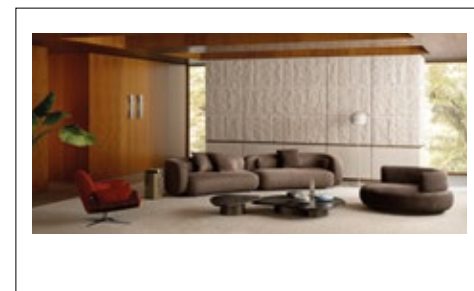

COMPOSITION DIMENSIONS CM 376X124
BÉZIER ELEMENT WITH 1 ARMREST SX CM 188X124 H79
BÉZIER ELEMENT WITH 1 ARMREST DX CM 188X124 H79
 FABRIC: TRINITY 05 EBANO (ART 42)
BÉZIER CUSHIONS

LEATHER: BIG SUR 03 CACAO (BIG SUR - CARMEL LEATHER)

BÉZIER ARMCHAIR / PAOLINA SX CM 114X156 H79
 LEATHER: BIG SUR 03 CACAO (BIG SUR - CARMEL LEATHER)

LAUREL ARMCHAIR CM 96X97 H76
 FABRIC: TRINITY 08 CORALLO (ART 42)
 SHELL: LIGHT BROWN STAINED CANALETTO WALNUT
 BASE: POLISHED CHROME METAL

BÉZIER COFFEE TABLE CM 105X80 H24
BÉZIER COFFEE TABLE CM 143X138 H20
 TOP: PIERRE BLEUE STONE

BASE: VARNISHED POLISHED BRONZE COLOUR METAL

ZEALAND RUG CM 700X500 / ASH COLOUR - SPECIAL SIZE

40/41 - 42/43



DIAGRAMMA HORIZONTAL SIDEBOARD DX CM 261X64 H38
 STRUCTURE: GLOSSY MOKA COLOUR LACQUERED
 LEGS AND SIDES: POLISHED STAINLESS STEEL

ZEALAND RUG CM 700X500 / SAGE COLOUR - SPECIAL SIZE

60/61

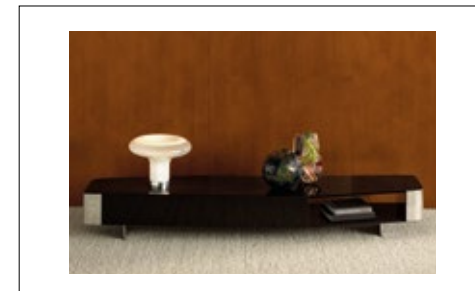
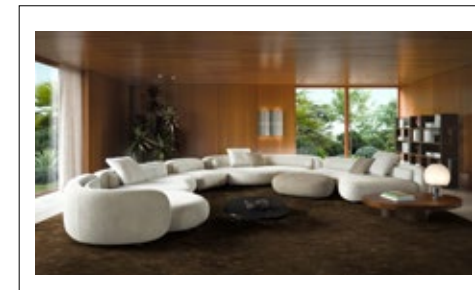

COMPOSITION DIMENSIONS CM 600X584
BÉZIER CHAISE-LONGUE SX CM 190X210 H84
BÉZIER CENTRAL ELEMENT WITH DOUBLE DEPTH SX CM 220X188 H84
BÉZIER CENTRAL ELEMENT CM 127X106 H79
BÉZIER CENTRAL ELEMENT WITH DOUBLE DEPTH SX CM 274X224 H84
BÉZIER CENTRAL ELEMENT WITH DOUBLE DEPTH DX CM 274X224 H84
 FABRIC: MONTEREY 02 ECRU (ART 43)
BÉZIER OTTOMAN CM 78X121 H41
BÉZIER CUSHIONS

LEATHER: BIG SUR 02 TORTORA (BIG SUR - CARMEL LEATHER)

BÉZIER COFFEE TABLE CM 151,5X97 H28
 TOP: LIGHT BROWN STAINED CANALETTO WALNUT
 BASE: VARNISHED POLISHED BRONZE COLOUR METAL

90 - 91 - 92/93

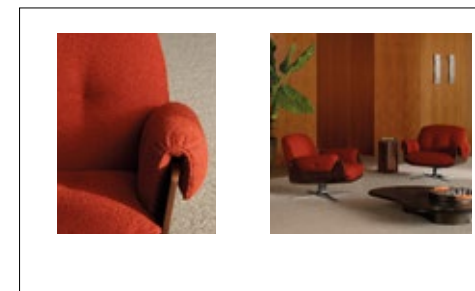

LAUREL ARMCHAIRS CM 96X97 H76
 FABRIC: TRINITY 08 CORALLO (ART 42)
 SHELL: LIGHT BROWN STAINED CANALETTO WALNUT
 BASE: POLISHED CHROME METAL

ANDRÉE SIDE TABLE CM 36X31 H48,5
 STRUCTURE COVER: GLAZED CORTEN COLOUR CERAMIC
 PLATES: POLISHED CHROME BRASS

BÉZIER COFFEE TABLE CM 143X138 H20
 TOP: PIERRE BLEUE STONE

BASE: VARNISHED POLISHED BRONZE COLOUR METAL

ZEALAND RUG CM 700X500 / ASH COLOUR - SPECIAL SIZE

94/95 - 96/97

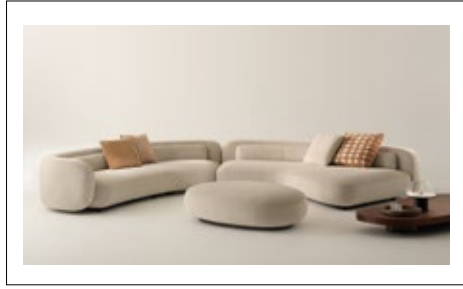

COMPOSITION DIMENSIONS CM 482X275
BÉZIER ELEMENT WITH 1 ARMREST SX CM 208X275 H79
BÉZIER CENTRAL ELEMENT DX CM 274X224 H84 - DOUBLE DEPTH
BÉZIER OTTOMAN CM 114X156 H41
 FABRIC: NEVADA 03 NUVOLO (ART 42)
BÉZIER CUSHIONS
 LEATHER: BIG SUR 04 CANNELLA (BIG SUR - CARMEL LEATHER)
 FABRIC: PRASLIN SMALL 04 TANGANICA (ART 42)
 FABRIC: PRASLIN BIG 04 TANGANICA (ART 42)
BÉZIER COFFEE TABLE CM 206X101 H20
BÉZIER COFFEE TABLE CM 105X80 H24
 TOP: LIGHT BROWN STAINED CANALETTO WALNUT
 BASE: TEXTURED BRONZE COLOUR METAL

118/119

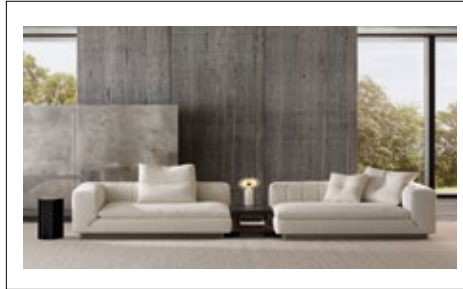

COMPOSITION DIMENSIONS CM 434X132
RILEY ELEMENT WITH 1 ARMREST SX CM 192X112 H85
RILEY DEEP - ELEMENT WITH 1 ARMREST DX CM 192X132 H85
 FABRIC: MONTEREY 02 ECRU (ART 43)
 BASE: VARNISHED POLISHED BRONZE COLOUR METAL
STAGE COFFEE TABLE CM 50X108 H32
 UPPER TOP: GLOSSY MOKA COLOUR LACQUERED
 LOWER TOP: LIGHT BROWN STAINED CANALETTO WALNUT
 BASE AND STORAGE COMPARTMENT: VARNISHED POLISHED BRONZE COLOUR METAL
ANDRÉE SIDE TABLE CM 35,5X21 H48,5
 STRUCTURE: ASH LICORICE COLOUR LACQUER
 PLATES: POLISHED CHROME BRASS
ZEALAND RUG CM 700X500 / ASH COLOUR - SPECIAL SIZE

126/127 - 135

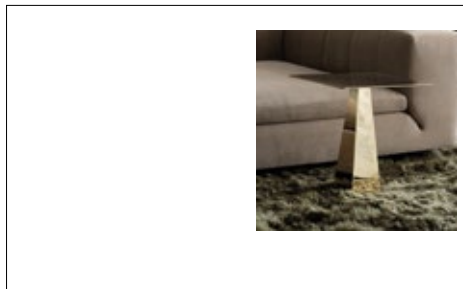

CAMEO SIDE TABLE CM 40X40 H46,5
 STRUCTURE: POLISHED CHAMPAGNE CHROME ALUMINIUM
ALPS RUGS CM 350X400 / MOSS COLOUR - SPECIAL SIZE

98/99 - 100/101 - 102 - 103



LINHA LIVRE DINING TABLE CM 400X145 H75
 TOP: LIGHT BROWN STAINED CANALETTO WALNUT
 LEGS: ANTIQUE BRONZE COLOUR LACQUERED
TRIO DINING LITTLE ARMCHAIRS CM 67X69 H84
 FABRIC: FREEMONT 02 GESSO (ART 42)
 STRUCTURE: LIGHT BROWN STAINED CANALETTO WALNUT
 FRAME: VARNISHED POLISHED CHESTNUT COLOUR METAL
FAIRWAY RUG CM 700X400 / MOSS COLOUR - SPECIAL SIZE

120/121 - 122/123 - 125

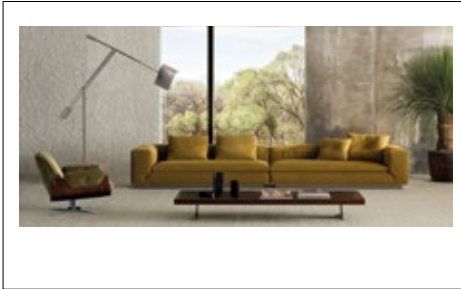

COMPOSITION DIMENSIONS CM 424X112
RILEY ELEMENT WITH 1 ARMREST SX CM 212X112 H85
RILEY ELEMENT WITH 1 ARMREST DX CM 212X112 H85
 LEATHER: MONTEREY 11 CURRY (ART 43)
 BASE: POLISHED BLACK CHROME METAL
LAUREL ARMCHAIR CM 96X97 H76
 LEATHER: BIG SUR 06 OLIVA (BIG SUR - CARMEL LEATHER)
 SHELL: LIGHT BROWN STAINED CANALETTO WALNUT
 BASE: POLISHED CHROME METAL
LIBRA COFFEE TABLE CM 220X80 H28
 TOP: LIGHT BROWN STAINED CANALETTO WALNUT
 LEGS: VARNISHED MATT BLACK COLOUR METAL
 CYLINDRICAL BARS: POLISHED CHROME METAL
ZEALAND RUG CM 700X500 / ASH COLOUR - SPECIAL SIZE

136/137 - 138/139 - 141

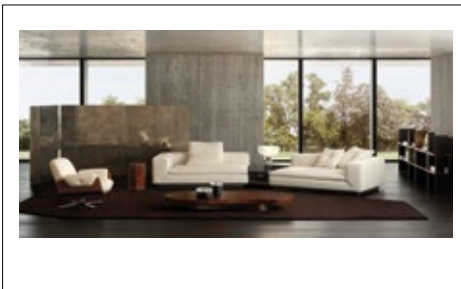

COMPOSITION DIMENSIONS CM 454X243
RILEY ELEMENT WITH 1 ARMREST SX CM 192X112 H85
RILEY DEEP - ELEMENT WITH 1 ARMREST DX CM 192X132 H85
 FABRIC: MONTEREY 02 ECRU (ART 43)
 BASE: VARNISHED POLISHED BRONZE COLOUR METAL
STAGE COFFEE TABLE SX CM 93X128 H32
 UPPER TOP: GLOSSY MOKA COLOUR LACQUERED
 LOWER TOP: LIGHT BROWN STAINED CANALETTO WALNUT
 BASE: VARNISHED POLISHED BRONZE COLOUR METAL
BÉZIER COFFEE TABLE CM 206X101 H20
 TOP: LIGHT BROWN STAINED CANALETTO WALNUT
 BASE: TEXTURED BRONZE COLOUR METAL
ANDRÉE SIDE TABLE CM 36X31 H48,5
 STRUCTURE COVER: GLAZED CORTEN COLOUR CERAMIC
 PLATES: POLISHED CHROME BRASS

104 - 105

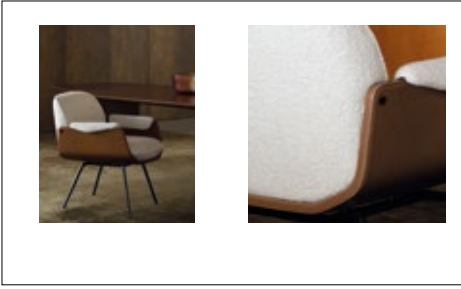

LAUREL DINING LITTLE ARMCHAIR CM 63X70 H81
 FABRIC: MONTEREY 01 NUVOLO (ART 43)
 SHELL: CARMEL 02 TANGANICA (BIG SUR - CARMEL LEATHER)
 BASE: VARNISHED POLISHED BLACK COFFEE COLOUR METAL
FAIRWAY RUG CM 700X400 / MOSS COLOUR - SPECIAL SIZE

126/127

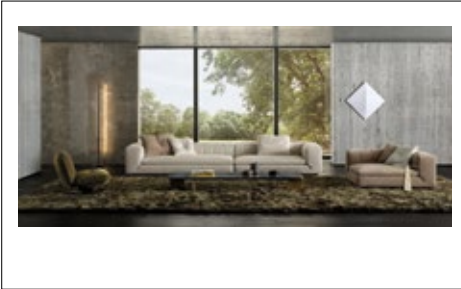

COMPOSITION DIMENSIONS CM 384X112
RILEY ELEMENT WITH 1 ARMREST SX CM 212X112 H85
RILEY ELEMENT WITH 1 ARMREST DX CM 172X112 H85
 LEATHER: TRINITY 02 NATURALE (ART 42)
 BASE: VARNISHED POLISHED BRONZE COLOUR METAL
RILEY CUSHION
 LEATHER: BIG SUR 02 TORTORA (BIG SUR - CARMEL LEATHER)
RILEY DEEP - CORNER ELEMENT WITH ARMREST DX CM 132X132 H85
 LEATHER: BIG SUR 02 TORTORA (BIG SUR - CARMEL LEATHER)
 BASE: VARNISHED POLISHED BRONZE COLOUR METAL
RILEY CUSHION
 FABRIC: TRINITY 02 NATURALE (ART 42)
LIBRA ARMCHAIR CM 76X86 H70
 LEATHER: BIG SUR 06 OLIVA (BIG SUR - CARMEL LEATHER)
 LEGS: VARNISHED MATT BLACK COLOUR METAL
 CYLINDRICAL BARS: POLISHED CHROME METAL

142 - 143 - 145

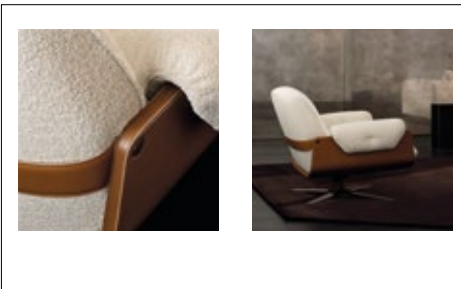

LAUREL ARMCHAIR CM 96X97 H76
 FABRIC: MONTEREY 02 ECRU (ART 43)
 SHELL AND POSTERIOR BAND: CARMEL 02 TANGANICA (BIG SUR - CARMEL LEATHER)
 BASE: VARNISHED POLISHED BLACK COFFEE COLOUR METAL
ANDRÉE SIDE TABLE CM 35,5X21 H48,5
 STRUCTURE: ASH LICORICE COLOUR LACQUER
 PLATES: POLISHED CHROME BRASS

106/107

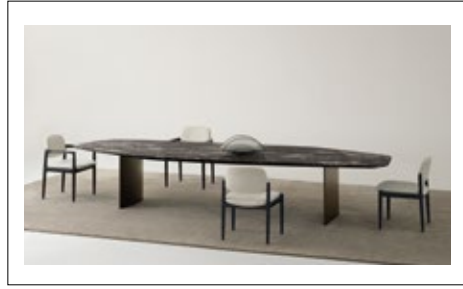

LINHA LIVRE DINING TABLE CM 400X145 H74,5
 TOP: GRIGIO OROBICO MARBLE
 LEGS: ANTIQUE BRONZE COLOUR LACQUERED
YOKO DINING LITTLE ARMCHAIRS CM 62X58 H81
YOKO DINING LITTLE ARMCHAIRS WITHOUT ARMRESTS CM 59X58 H81
 FABRIC: LARRY 02 ECRU (ART 39)
 STRUCTURE: ASH LICORICE COLOUR LACQUER
FAIRWAY RUG CM 700X400 / CORD COLOUR - SPECIAL SIZE

126/127 - 128 - 129



YVES COFFEE TABLE CM 220X80 H26,5
 TOP: GRIGIO OROBICO MARBLE
 LEGS: ACID-ETCHED BRASS
ALPS RUGS CM 350X400 / MOSS COLOUR - SPECIAL SIZE

146/147



COMPOSITION DIMENSIONS CM 538X212
RILEY CHAISE-LONGUE SX CM 172X172 H85
RILEY CENTRAL ELEMENT CM 184X112 H85
RILEY CHAISE-LONGUE DX CM 132X212 H85
 FABRIC: SIERRA 02 ECRU (ART 43)
 BASE: POLISHED BLACK CHROME METAL
RILEY CUSHIONS
 LEATHER: BIG SUR 01 AVORIO (BIG SUR - CARMEL LEATHER)
STAGE COFFEE TABLE CM 50X108 H32
 TOPS: GLOSSY MOKA COLOUR LACQUERED
 BASE AND STORAGE COMPARTMENT: POLISHED BLACK CHROME METAL
SAKI ARMCHAIRS WITHOUT ARMRESTS WITH BASE CM 80X92 H66
 FABRIC: TRINITY 06 TANGANICA (ART 42)
 SUPPORT PANELS: CARMEL 02 TANGANICA (BIG SUR - CARMEL LEATHER)
 BASE: VARNISHED POLISHED BLACK COFFEE COLOUR METAL
YVES COFFEE TABLE CM 120X120 H26,5
 TOP: CALACATTA MARBLE
 LEGS: POLISHED CHAMPAGNE CHROME ALUMINIUM

110/111 - 113 - 114/115



COMPOSITION DIMENSIONS CM 384X132
RILEY DEEP - ELEMENT WITH 1 ARMREST SX CM 192X132 H85
RILEY DEEP - ELEMENT WITH 1 ARMREST DX CM 192X132 H85
 LEATHER: BIG SUR 03 CACA0 (BIG SUR - CARMEL LEATHER)
 BASE: POLISHED BLACK CHROME METAL
ANDRÉE COFFEE TABLES CM 120X116,5 H24
 STRUCTURE COVER: GLAZED CORTEN COLOUR CERAMIC
JAMES SIDE TABLE CM 35X35 H45
 STRUCTURE: POLISHED STAINLESS STEEL
ZEALAND RUG CM 700X500 / SAGE COLOUR - SPECIAL SIZE

130 - 131

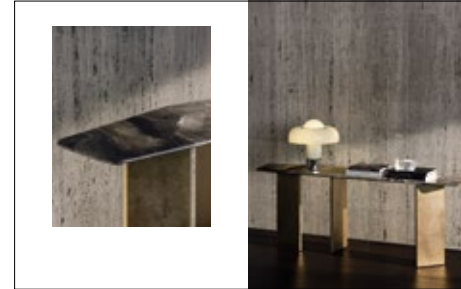

YVES CONSOLE TABLE CM 200X46 H72
 TOP: GRIGIO OROBICO MARBLE
 LEGS: ACID-ETCHED BRASS

148/149 - 150 - 151 - 153

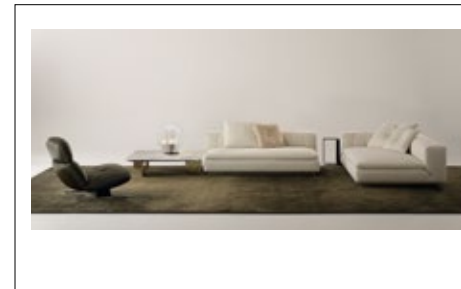

RILEY CENTRAL ELEMENT CM 184X112 H85
RILEY CHAISE-LONGUE DX CM 132X212 H85
 FABRIC: MONTEREY 02 ECRU (ART 43)
 BASE: VARNISHED POLISHED BRONZE COLOUR METAL
RILEY CUSHION
 LEATHER: BIG SUR 01 AVORIO (BIG SUR - CARMEL LEATHER)
LIBRA BERGÈRE CM 78X98 H82
 LEATHER: CARMEL 04 MUSCHIO (BIG SUR - CARMEL LEATHER)
 LEGS: VARNISHED MATT BLACK COLOUR METAL
 CYLINDRICAL BARS: POLISHED CHROME METAL
YVES COFFEE TABLE CM 120X120 H26,5
 TOP: CALACATTA MARBLE
 BASE: POLISHED CHAMPAGNE CHROME ALUMINIUM
FAIRWAY RUG CM 700X400 / MOSS COLOUR - SPECIAL SIZE

114/115 - 116/117

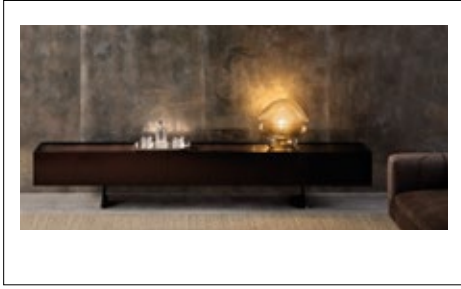

LIBRA LIVING HORIZONTAL SIDBOARD CM 301,5X55,5 H45
 TOP: BACKPAINTED MOKA COLOUR GLASS
 STRUCTURE: GLOSSY MOKA COLOUR LACQUERED
 LEGS: VARNISHED MATT BLACK COLOUR METAL
 CYLINDRICAL BARS: POLISHED CHROME METAL
ZEALAND RUG CM 700X500 / SAGE COLOUR - SPECIAL SIZE

132/133

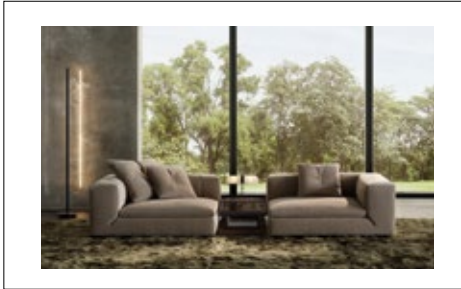

COMPOSITION DIMENSIONS CM 314X132
RILEY DEEP - CORNER ELEMENT WITH ARMREST SX CM 132X132 H85
RILEY DEEP - CORNER ELEMENT WITH ARMREST DX CM 132X132 H85
 LEATHER: BIG SUR 02 TORTORA (BIG SUR - CARMEL LEATHER)
 BASE: POLISHED BLACK CHROME METAL
STAGE COFFEE TABLE CM 50X128 H32
 UPPER TOP: GLOSSY MOKA COLOUR LACQUERED
 LOWER TOP: LIGHT BROWN STAINED CANALETTO WALNUT
 BASE AND STORAGE COMPARTMENT: POLISHED BLACK CHROME METAL
ALPS RUGS CM 350X400 / MOSS COLOUR - SPECIAL SIZE

154/155



COMPOSITION DIMENSIONS CM 404X212
RILEY ELEMENT WITH 1 ARMREST SX CM 272X112 H85
RILEY CHAISE-LONGUE DX CM 132X212 H85
 FABRIC: MONTEREY 02 ECRU (ART 43)
 BASE: POLISHED BLACK CHROME METAL
YVES COFFEE TABLE CM 220X80 H26,5
 TOP: GRIGIO OROBICO MARBLE
 LEGS: ACID-ETCHED BRASS
ALPS RUG CM 450X350 / CASHMERE COLOUR

156 - 157



STAGE COFFEE TABLE CM 50X108 H32
TOPS: LIGHT BROWN STAINED CANALETTO WALNUT
BASE AND STORAGE COMPARTMENT: POLISHED BLACK CHROME METAL
ALPS RUG CM 450X350 / CASHMERE COLOUR

160/161 - 163

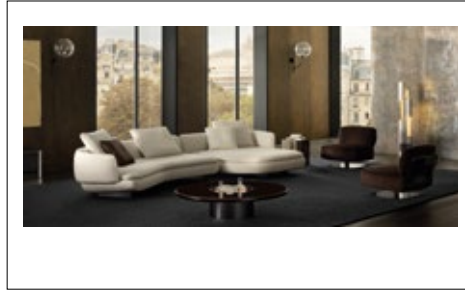

COMPOSITION DIMENSIONS CM 400X163
VIVIENNE INCLINED ELEMENT WITH 1 ARMREST SX CM 242X154 H80
VIVIENNE CHAISE-LONGUE DX CM 158X163 H80
FABRIC: TRINITY 02 NATURALE (ART 42)
BASES: BRUSHED POLISHED ALUMINIUM
VIVIENNE CUSHION
LEATHER: CARMEL 03 EBANO (BIG SUR - CARMEL LEATHER)
SAKI ARMCHAIRS WITHOUT ARMRESTS WITH BASE CM 80X92 H66
FABRIC: NEVADA 06 MOKA (ART 42)
SUPPORT PANELS: GLOSSY MOKA COLOUR LACQUERED
BASE: VARNISHED POLISHED BLACK COFFEE COLOUR METAL
HELENE COFFEE TABLE Ø CM 130 H30
TOP/EDGE: GLOSSY MOKA COLOUR LACQUERED
BASE/INSERTED TRAY ELEMENT: POLISHED STAINLESS STEEL
ZEALAND RUG CM 700X500 / CHARCOAL COLOUR - SPECIAL SIZE

164/165 - 166 - 167

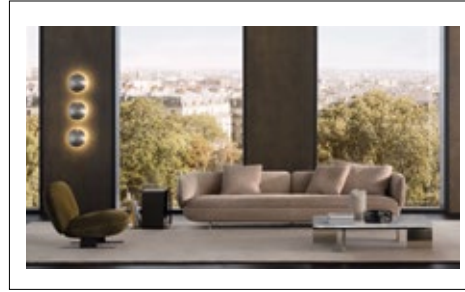

VIVIENNE SOFA CM 276X107 H80
LEATHER: BIG SUR 02 TORTORA (BIG SUR - CARMEL LEATHER)
BASES: BRUSHED POLISHED ALUMINIUM
LIBRA ARMCHAIR CM 76X86 H70
LEATHER: BIG SUR 06 OLIVA (BIG SUR - CARMEL LEATHER)
LEGS: VARNISHED MATT BLACK COLOUR METAL
CYLINDRICAL BARS: POLISHED CHROME METAL
YVES COFFEE TABLE CM 120X120 H26,5
TOP: CALACAT TA MARBLE
LEGS: POLISHED CHAMPAGNE CHROME ALUMINIUM
NASTRO SIDE TABLE CM 55X50 H45
EXTERNAL STRUCTURE: DEEP SATIN BROWN COLOUR METAL / VARNISHED POLISHED BURNT BROWN COLOUR METAL
INTERNAL STRUCTURE: VARNISHED POLISHED BURNT BROWN COLOUR METAL

168/169 - 174 - 175 - 177



COMPOSITION DIMENSIONS CM 403X163
VIVIENNE ELEMENT WITH 1 ARMREST SX CM 245X107 H80
VIVIENNE CHAISE-LONGUE DX CM 158X163 H80
LEATHER: MONTEREY 01 NUVOLO (ART 43)
BASES: BRUSHED POLISHED ALUMINIUM
LAUREL ARMCHAIR CM 96X97 H76
LEATHER: BIG SUR 06 OLIVA (BIG SUR - CARMEL LEATHER)
SHELL: LIGHT BROWN STAINED CANALETTO WALNUT
BASE: POLISHED CHROME METAL
BÉZIER COFFEE TABLE CM 206X101 H20
TOP: LIGHT BROWN STAINED CANALETTO WALNUT
BASE: TEXTURED BRONZE COLOUR METAL
ANDRÉE SIDE TABLE CM 35,5X21 H48,5
STRUCTURE COVER: GLAZED CERAMIC PUTTY COLOUR
PLATES: POLISHED CHROME BRASS

170/171 - 173



COMPOSITION DIMENSIONS CM 403X163
VIVIENNE ELEMENT WITH 1 ARMREST WITH TOP SX CM 245X107 H80
VIVIENNE CHAISE-LONGUE DX CM 158X163 H80
LEATHER: MONTEREY 01 NUVOLO (ART 43)
TABLE-TOP: GLOSSY CAPPUCCINO COLOUR LACQUERED
BASES: BRUSHED POLISHED ALUMINIUM
BÉZIER COFFEE TABLE CM 206X101 H20
TOP: LIGHT BROWN STAINED CANALETTO WALNUT
BASE: TEXTURED BRONZE COLOUR METAL
ZEALAND RUG CM 700X500 / ASH COLOUR - SPECIAL SIZE

178/179 - 180/181 - 182/183 - 185



COMPOSITION DIMENSIONS CM 374X272
VIVIENNE INCLINED ELEMENT WITH 1 ARMREST SX CM 242X154 H80
VIVIENNE CORNER CHAISE-LONGUE DX CM 132X132 H80
VIVIENNE ELEMENT WITH 1 ARMREST DX CM 140X107 H80
FABRIC: ORION 03 CORDA (ART 40)
BASES: BRUSHED POLISHED ALUMINIUM
LIBRA ARMCHAIR CM 76X86 H70
LEATHER: BIG SUR 06 OLIVA (BIG SUR - CARMEL LEATHER)
LEGS: VARNISHED MATT BLACK COLOUR METAL
CIRCULAR BARS: POLISHED CHROME METAL
YVES COFFEE TABLE Ø CM 120 H26,5
TOP: MARRON DAMASCO MARBLE
LEGS: POLISHED CHAMPAGNE CHROME ALUMINIUM
JAMES SIDE TABLE CM 35X35 H45
STRUCTURE: POLISHED STAINLESS STEEL
ZEALAND RUG CM 700X500 / ASH COLOUR - SPECIAL SIZE

185 - 186/187 - 188/189 - 190 - 191

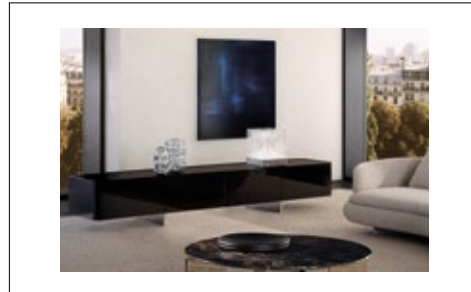

YVES LIVING HORIZONTAL SIDEBOARD CM 230,5X54 H48
TOP: LIGHT BROWN STAINED CANALETTO WALNUT
STRUCTURE: GLOSSY MOKA COLOUR LACQUERED
LEGS: POLISHED CHAMPAGNE CHROME ALUMINIUM
YVES COFFEE TABLE Ø CM 120 H26,5
TOP: MARRON DAMASCO MARBLE
LEGS: POLISHED CHAMPAGNE CHROME ALUMINIUM
ZEALAND RUG CM 700X500 / ASH COLOUR - SPECIAL SIZE

192/193 - 195 - 196 - 197 - 199 - 200 - 201

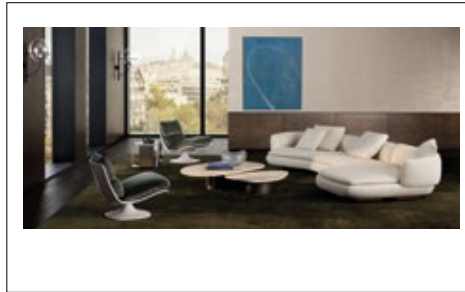

COMPOSITION DIMENSIONS CM 400X163
VIVIENNE INCLINED ELEMENT WITH 1 ARMREST SX CM 242X154 H80
VIVIENNE CHAISE-LONGUE DX CM 158X163 H80
FABRIC: TRINITY 02 NATURALE (ART 42)
BASES: VARNISHED POLISHED BLACK COFFEE COLOUR ALUMINIUM
PATTIE ARMCHAIRS CM 78X91 H76
FABRIC: KABUKI 14 SALVIA (ART KABUKI)
SHELL: GLOSSY WARM GREY COLOUR LACQUERED
BASE: VARNISHED POLISHED WARM GREY COLOUR METAL
BÉZIER COFFEE TABLE CM 151,5X97 H28
BÉZIER COFFEE TABLE CM 105X80 H24
TOP: TRAVERTINE STONE
BASE: TEXTURED BRONZE COLOUR METAL
FAIRWAY RUG CM 700X400 / MOSS COLOUR - SPECIAL SIZE

202 - 203



NASTRO SIDE TABLE CM 55X50 H45
EXTERNAL STRUCTURE: SATIN / POLISHED STAINLESS STEEL
INTERNAL STRUCTURE: VARNISHED POLISHED BIRCH GREY COLOUR METAL
PATTIE ARMCHAIR CM 78X91 H76
FABRIC: KABUKI 14 SALVIA (ART KABUKI)
SHELL: GLOSSY WARM GREY COLOUR LACQUERED
BASE: VARNISHED POLISHED WARM GREY COLOUR METAL
FAIRWAY RUG CM 700X400 / MOSS COLOUR - SPECIAL SIZE

204/205



COMPOSITION DIMENSIONS CM 385X107
VIVIENNE ELEMENT WITH 1 ARMREST SX CM 245X107 H80
VIVIENNE ELEMENT WITH 1 ARMREST DX CM 140X107 H80
VIVIENNE OTTOMAN WITH TOP SX CM 143X143 H40
FABRIC: MONTEREY 01 NUVOLO (ART 43)
TOP: GLOSSY MOKA COLOUR LACQUERED
BASES: VARNISHED POLISHED BLACK COFFEE COLOUR ALUMINIUM
VIVIENNE CUSHIONS
LEATHER: BIG SUR 03 CACAO (BIG SUR - CARMEL LEATHER)
SAKI ARMCHAIRS WITHOUT ARMRESTS WITH BASE CM 80X92 H66
FABRIC: FREEMONT 06 TANGANICA (ART 42)
SUPPORT PANELS: GLOSSY MOKA COLOUR LACQUERED
BASE: VARNISHED POLISHED BLACK COFFEE COLOUR METAL

206/207



COMPOSITION DIMENSIONS CM 385X107
VIVIENNE ELEMENT WITH 1 ARMREST SX CM 245X107 H80
VIVIENNE ELEMENT WITH 1 ARMREST DX CM 140X107 H80
FABRIC: MONTEREY 01 NUVOLO (ART 43)
BASES: VARNISHED POLISHED BLACK COFFEE COLOUR ALUMINIUM
NASTRO CONSOLE TABLE CM 160X40 H46,5
EXTERNAL STRUCTURE: SATIN / POLISHED STAINLESS STEEL
INTERNAL STRUCTURE: VARNISHED POLISHED BIRCH GREY COLOUR METAL

208/209



COMPOSITION DIMENSIONS CM 286X143
VIVIENNE OTTOMAN WITH TOP SX CM 143X143 H40
VIVIENNE OTTOMAN WITH TOP DX CM 143X143 H40
FABRIC: MONTEREY 01 NUVOLO (ART 43)
TOP: GLOSSY MOKA COLOUR LACQUERED
BASES: VARNISHED POLISHED BLACK COFFEE COLOUR ALUMINIUM
TAIKO SIDE TABLE CM 46X35 H48
STRUCTURE: VARNISHED POLISHED MOKA COLOUR ALUMINIUM

210/211

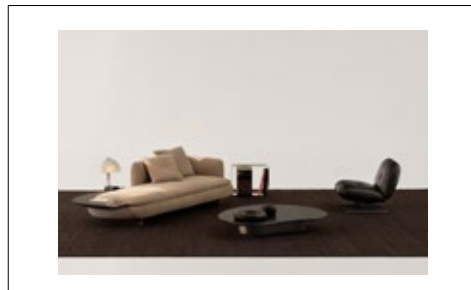

VIVIENNE SOFA WITH TOP DX CM 290X118 H80 - BACKREST CM 125
LEATHER: BIG SUR 02 TORTORA (BIG SUR - CARMEL LEATHER)
TOP: GLOSSY MOKA COLOUR LACQUERED
BASE: VARNISHED POLISHED BLACK COFFEE COLOUR ALUMINIUM
LIBRA ARMCHAIR CM 76X86 H70
LEATHER: CARMEL 03 EBANO (BIG SUR - CARMEL LEATHER)
LEGS: VARNISHED MATT BLACK COLOUR METAL
CYLINDRICAL BARS: POLISHED CHROME METAL
BÉZIER COFFEE TABLE CM 143X138 H20
TOP: PIERRE BLEUE STONE
BASE: VARNISHED POLISHED BRONZE COLOUR METAL
NASTRO SIDE TABLE CM 55X50 H45
EXTERNAL STRUCTURE: SATIN / POLISHED STAINLESS STEEL
INTERNAL STRUCTURE: VARNISHED POLISHED BIRCH GREY COLOUR METAL
ZEALAND RUG CM 700X500 / MOKA COLOUR - SPECIAL SIZE

214/215 - 217 - 218 - 219 - 220/221

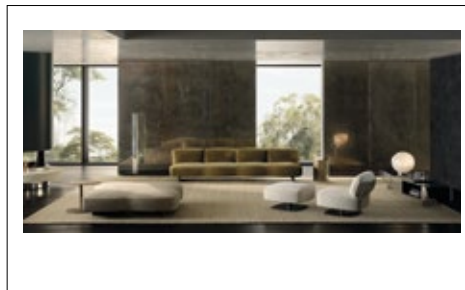

SAKI CENTRAL ELEMENT CM 304X95 H70
SAKI CENTRAL ELEMENT CM 156X91 H70
LEATHER: BIG SUR 06 OLIVA (BIG SUR - CARMEL LEATHER)
SUPPORT PANELS: GLOSSY ARMY GREEN COLOUR LACQUERED
FEET/BASE: VARNISHED POLISHED BLACK COFFEE COLOUR ALUMINIUM
SAKI ARMCHAIR WITHOUT ARMRESTS WITH BASE CM 80X92 H66
SAKI FOOTSTOOL/OTTOMAN WITH BASE CM 80X78 H42
FABRIC: MONTEREY 03 SABBIA (ART 43)
SUPPORT PANEL: GLOSSY CAPPUCCINO COLOUR LACQUERED
BASE: VARNISHED POLISHED BLACK COFFEE COLOUR METAL
SAKI ISLAND CM 156X156 H41 - MOD. G
FABRIC: TRINITY 04 SALVIA (ART 42)
FEET/BASE: VARNISHED POLISHED BLACK COFFEE COLOUR ALUMINIUM
DIAGRAMMA HORIZONTAL SIDEBOARD DX CM 261X64 H38
STRUCTURE: GLOSSY MOKA COLOUR LACQUERED
LEGS AND SIDES: POLISHED STAINLESS STEEL
TAIKO SIDE TABLE CM 67X48 H48
STRUCTURE: VARNISHED POLISHED CAPPUCCINO COLOUR ALUMINIUM
ZEALAND RUG CM 700X500 / SAGE COLOUR - SPECIAL SIZE

222/223 - 224 - 225 - 227 - 228 - 229 - 230 - 231 - 232 - 233

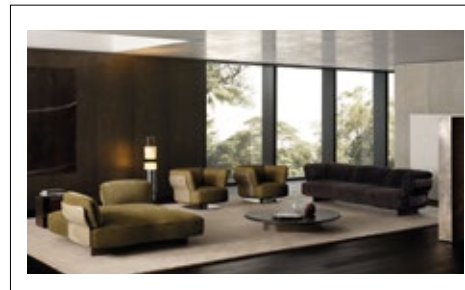

SAKI SOFA CM 254X95 H70
FABRIC: FREEMONT 05 CIOCCOLATO (ART 42)
SUPPORT PANELS: GLOSSY MOKA COLOUR LACQUERED
FEET/BASE: VARNISHED POLISHED BLACK COFFEE COLOUR ALUMINIUM
SAKI ARMCHAIRS WITH BASE CM 104X92 H70
FABRIC: NEVADA 14 OLIVA (ART 42)
SAKI ISLAND CM 168X168 H70 - MOD. E
LEATHER: BIG SUR 06 OLIVA (BIG SUR - CARMEL LEATHER)
SUPPORT PANELS: GLOSSY CAPPUCCINO COLOUR LACQUERED
FEET/BASE: VARNISHED POLISHED BLACK COFFEE COLOUR ALUMINIUM
BÉZIER COFFEE TABLE CM 143X138 H20
TOP: PIERRE BLEUE STONE
BASE: VARNISHED POLISHED BRONZE COLOUR METAL
NASTRO SIDE TABLE CM 55X50 H45
EXTERNAL STRUCTURE: DEEP SATIN BROWN COLOUR METAL / VARNISHED POLISHED BURNT BROWN COLOUR METAL
INTERNAL STRUCTURE: VARNISHED POLISHED BURNT BROWN COLOUR METAL
FAIRWAY RUG CM 700X500 / CORD COLOUR - SPECIAL SIZE

234/235 - 236 - 237



SAKI ARMCHAIR WITH BASE CM 104X92 H70
SAKI ARMCHAIRS WITHOUT ARMRESTS WITH BASE CM 80X92 H66
SAKI FOOTSTOOL/OTTOMAN WITH BASE CM 80X78 H42
FABRIC: FREEMONT 06 TANGANICA (ART 42)
SUPPORT PANELS: CARMEL 02 TANGANICA (BIG SUR - CARMEL LEATHER)
FEET/BASE: VARNISHED POLISHED BLACK COFFEE COLOUR ALUMINIUM
HELENE COFFEE TABLE Ø CM 130 H30
TOP/EDGE: GLOSSY MOKA COLOUR LACQUERED
BASE/INSERTED TRAY ELEMENT: POLISHED STAINLESS STEEL

238/239 - 240 - 241



SAKI DINING TABLE CM 220X135 H74
TOP: PIERRE BLEUE STONE
BASE: GLOSSY MOKA COLOUR LACQUERED
TAPE DINING LITTLE ARMCHAIRS CM 63X61 H72,5
FABRIC: TRINITY 06 TANGANICA (ART 42)
BASE: VARNISHED POLISHED BLACK COFFEE COLOUR METAL
FAIRWAY RUG CM 700X400 / CORD COLOUR - SPECIAL SIZE

242/243

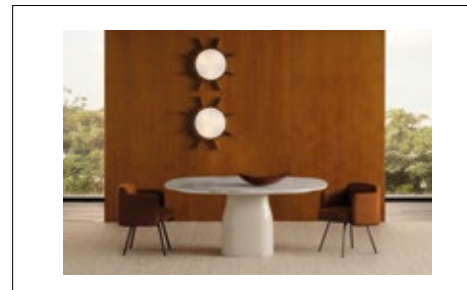

SAKI DINING TABLE CM 170X170 H74
TOP: CALACATTA MARBLE
BASE: GLOSSY WARM GREY COLOUR LACQUERED
TAPE DINING LITTLE ARMCHAIRS CM 63X61 H72,5
FABRIC: TRINITY 06 TANGANICA (ART 42)
BASE: VARNISHED POLISHED BLACK COFFEE COLOUR METAL
ZEALAND RUG CM 700X500 / ASH COLOUR - SPECIAL SIZE

244/245 - 246 - 247

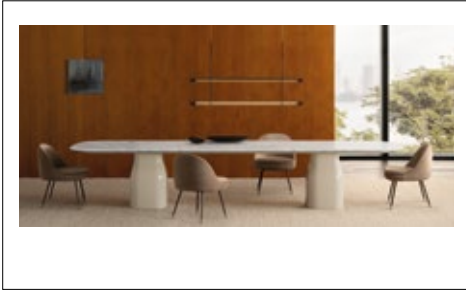

SAKI DINING TABLE CM 400X120 H74
TOP: CALACATTA MARBLE
BASES: GLOSSY WARM GREY COLOUR LACQUERED

SENDAL DINING LITTLE ARMCHAIRS CM 58X60 H77
LEATHER: BIG SUR 02 TORTORA (BIG SUR - CARMEL LEATHER)
LEGS: VARNISHED POLISHED BLACK COFFEE COLOUR METAL
TIPS: POLISHED CHAMPAGNE CHROME ALUMINIUM

ZEALAND RUG CM 700X500 / ASH COLOUR - SPECIAL SIZE

252/253 - 254 - 255 - 256/257

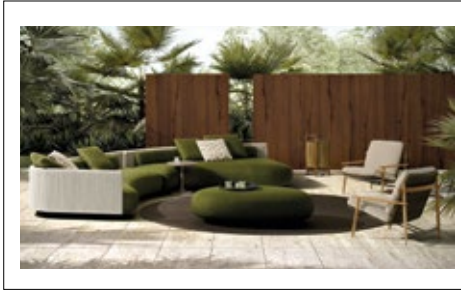

COMPOSITION DIMENSIONS CM 528X213

BÉZIER CORD OUTDOOR ELEMENT WITH 1 ARMREST SX CM 260X192 H85 - DOUBLE DEPTH
BÉZIER CORD OUTDOOR CENTRAL ELEMENT DX CM 268X213 H85 - DOUBLE DEPTH
BÉZIER CORD OUTDOOR OTTOMAN CM 114X156 H42
FABRIC: MUSTIQUE 13 MUSCHIO (ART LIFESCAPE 13)
CORD: ECRU COLOUR
BÉZIER CORD OUTDOOR CUSHIONS
FABRIC: HAITI 01 ECRU (ART LIFESCAPE 13)

TRIO OUTDOOR ARMCHAIRS CM 80X90 H80
FABRIC: ANTIGUA 03 ECRU (ART LIFESCAPE 13)
STRUCTURE: NATURAL TEAK
FIBER: MUD COLOUR
FRAME: VARNISHED POLISHED BRONZE COLOUR ALUMINIUM

TAIKO OUTDOOR SIDE TABLE CM 67X48 H48
STRUCTURE: VARNISHED POLISHED CAPPUCCINO COLOUR ALUMINIUM

AVERY RUG Ø CM 350 / DARK BROWN COLOUR

258/259 - 261

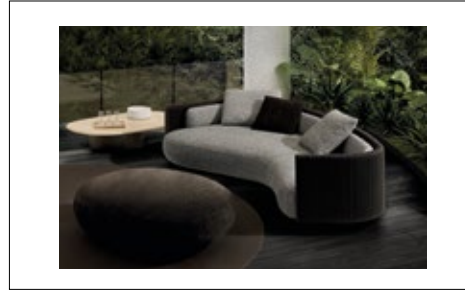

BÉZIER CORD OUTDOOR SOFA DX CM 270X154 H85 - DOUBLE DEPTH
FABRIC: MUSTIQUE 08 ANTRACITE (ART LIFESCAPE 13)
CORD: DARK BROWN COLOUR

BÉZIER CORD OUTDOOR CUSHION
FABRIC: ANTIGUA 07 MOKA (ART LIFESCAPE 13)

BÉZIER CORD OUTDOOR OTTOMAN CM 114X156 H42
FABRIC: ANTIGUA 07 MOKA (ART LIFESCAPE 13)

BÉZIER OUTDOOR COFFEE TABLE CM 151,5X97 H28
TOP: TRAVERTINE STONE
BASE: TEXTURED BRONZE COLOUR STAINLESS STEEL

AVERY RUG Ø CM 350 / DARK BROWN COLOUR

262/263 - 264/265 - 266 - 267

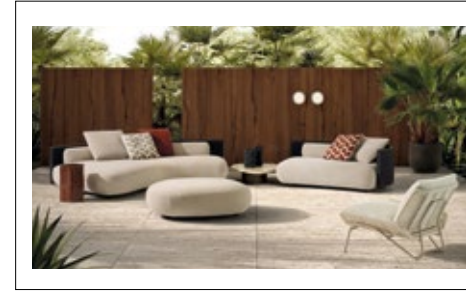

COMPOSITION DIMENSIONS CM 443X213

BÉZIER CORD OUTDOOR CENTRAL ELEMENT SX CM 268X213 H85 - DOUBLE DEPTH
BÉZIER CORD OUTDOOR ELEMENT WITH 1 ARMREST DX CM 175X113 H80
BÉZIER CORD OUTDOOR OTTOMAN CM 129X114 H42
FABRIC: ANTIGUA 03 ECRU (ART LIFESCAPE 13)
CORD: DARK BROWN COLOUR
BÉZIER CORD OUTDOOR CUSHIONS
FABRIC: HAITI 01 ECRU (ART LIFESCAPE 13)
FABRIC: ANTIGUA 08 RUGGINE (ART LIFESCAPE 13)
FABRIC: HAITI 03 RUGGINE (ART LIFESCAPE 13)

EMMI CORD OUTDOOR ARMCHAIR CM 97X98 H78
FABRIC: MUSTIQUE 01 BIANCO (ART LIFESCAPE 13)
STRUCTURE: MATT ECRU COLOUR STAINLESS STEEL
CORD: BUTTER COLOUR

BÉZIER OUTDOOR COFFEE TABLE CM 105X80 H24
TOP: TRAVERTINE STONE
BASE: TEXTURED BRONZE COLOUR STAINLESS STEEL

294/295 - 296 - 297 - 298/299

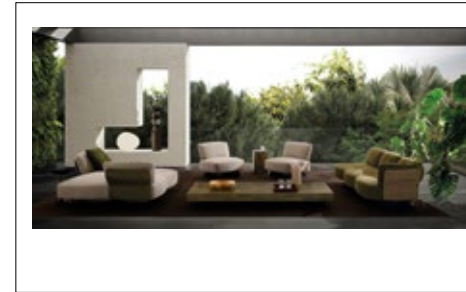

SAKI OUTDOOR ISLAND SX CM 168X168 H70 - MOD. E
FABRIC: ANTIGUA 03 ECRU (ART LIFESCAPE 13)
SUPPORT PANELS: GLOSSY ARMY GREEN COLOUR LACQUERED
SAKI OUTDOOR CUSHION
FABRIC: MUSTIQUE 13 MUSCHIO (ART LIFESCAPE 13)

SAKI CORD OUTDOOR ARMCHAIRS WITHOUT ARMRESTS CM 80X91 H69
FABRIC: ANTIGUA 03 ECRU (ART LIFESCAPE 13)
SUPPORT PANELS: GLOSSY ARMY GREEN COLOUR LACQUERED

SAKI CORD OUTDOOR ELEMENT WITH 1 ARMREST DX CM 242X95 H70
FABRIC: ANTIGUA 04 OLIVA (ART LIFESCAPE 13)
FIBRE: CAPPUCCINO COLOUR

TWIST OUTDOOR THROW CM 170X140 / CHALK/ECRU COLOUR

BRAID RUGS CM 250X350 / CHOCOLATE COLOUR - SPECIAL SIZE

268/269 - 270 - 271



BÉZIER CORD OUTDOOR ELEMENT WITH 1 ARMREST SX CM 175X113 H80
BÉZIER CORD OUTDOOR CENTRAL ELEMENTS CM 124X94 H80
BÉZIER CORD OUTDOOR ELEMENT WITH 1 ARMREST DX CM 124X101 H80
FABRIC: MUSTIQUE 04 RAME (ART LIFESCAPE 13)
CORD: DARK BROWN COLOUR
BÉZIER CORD OUTDOOR CUSHION
FABRIC: MADEIRA 07 TESTA DI MORO (ART LIFESCAPE 12)

BÉZIER CORD OUTDOOR OTTOMAN CM 114X156 H42
FABRIC: MUSTIQUE 05 TEAK (ART LIFESCAPE 13)

BÉZIER OUTDOOR COFFEE TABLE CM 105X80 H24
BÉZIER OUTDOOR COFFEE TABLE CM 143X138 H20
TOP: PIERRE BLEUE STONE
BASE: VARNISHED POLISHED BRONZE COLOUR STAINLESS STEEL

TRICOTI RUG Ø CM 400 / TEAK COLOUR

300/301

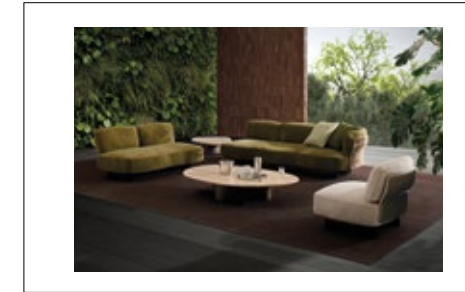

SAKI CORD OUTDOOR CENTRAL ELEMENT CM 156X91 H70
FABRIC: ANTIGUA 04 OLIVA (ART LIFESCAPE 13)
FIBRE: CAPPUCCINO COLOUR

SAKI CORD OUTDOOR ELEMENT WITH 1 ARMREST DX CM 242X95 H70
FABRIC: ANTIGUA 04 OLIVA (ART LIFESCAPE 13)
FIBRE: CAPPUCCINO COLOUR
SAKI CORD OUTDOOR CUSHION
FABRIC: MUSTIQUE 12 OLIVA (ART LIFESCAPE 13)
FABRIC: MUSTIQUE 13 MUSCHIO (ART LIFESCAPE 13)

SAKI OUTDOOR ARMCHAIR WITHOUT ARMRESTS CM 80X91 H69
FABRIC: ANTIGUA 03 ECRU (ART LIFESCAPE 13)
SUPPORT PANEL: GLOSSY ARMY GREEN COLOUR LACQUERED

BÉZIER OUTDOOR COFFEE TABLE CM 151,5X97 H28
BÉZIER OUTDOOR COFFEE TABLE CM 105X80 H24
TOP: TRAVERTINE STONE
BASE: TEXTURED BRONZE COLOUR STAINLESS STEEL

BRAID RUGS CM 250X350 / CHOCOLATE COLOUR - SPECIAL SIZE

272/273 - 274/275 - 276/277



BÉZIER CORD OUTDOOR ARMCHAIR/PAOLINA SX CM 121X163 H80
BÉZIER CORD OUTDOOR ARMCHAIR/PAOLINA DX CM 121X163 H80
FABRIC: ANTIGUA 08 RUGGINE (ART LIFESCAPE 13)
CORD: DARK BROWN COLOUR
BÉZIER CORD OUTDOOR OTTOMAN CM 129X114 H42
FABRIC: ANTIGUA 07 MOKA (ART LIFESCAPE 13)

BÉZIER OUTDOOR COFFEE TABLE CM 105X80 H24
BÉZIER OUTDOOR COFFEE TABLE CM 151,5X97 H28
TOP: TRAVERTINE STONE
BASE: TEXTURED BRONZE COLOUR STAINLESS STEEL

TAIKO OUTDOOR SIDE TABLE CM 46X35 H48
STRUCTURE: VARNISHED POLISHED MOKA COLOUR ALUMINIUM

AVERY RUG Ø CM 350 / DARK BROWN COLOUR

278/279 - 280/281



BÉZIER CORD OUTDOOR CENTRAL ELEMENT DX CM 268X213 H85 - DOUBLE DEPTH
BÉZIER CORD OUTDOOR ELEMENT WITH 1 ARMREST SX CM 260X192 H85 - DOUBLE DEPTH
BÉZIER CORD OUTDOOR OTTOMAN CM 114X156 H42
FABRIC: MUSTIQUE 13 MUSCHIO (ART LIFESCAPE 13)
CORD: ECRU COLOUR
BÉZIER CORD OUTDOOR CUSHION
FABRIC: HAITI 01 ECRU (ART LIFESCAPE 13)

282/283



ANDRÉE DINING OUTDOOR TABLE CM 287X94,5 H74
STRUCTURE COVER: GLAZED GREEN COLOUR CERAMIC

TRIO DINING LITTLE ARMCHAIRS CM 67X69 H84
FABRIC: MUSTIQUE 01 BIANCO (ART LIFESCAPE 13)
STRUCTURE: NATURAL TEAK
FIBER: MUD COLOUR
FRAME: VARNISHED POLISHED BRONZE COLOUR ALUMINIUM

KYOTO RUG CM 500X350 / ASH COLOUR - SPECIAL SIZE

286/287 - 288/289 - 291 - 293



SAKI OUTDOOR ELEMENT WITH 1 ARMREST DX CM 242X95 H70
FABRIC: ANTIGUA 01 BIANCO (ART LIFESCAPE 13)
SUPPORT PANELS: GLOSSY CAPPUCCINO COLOUR LACQUERED
SAKI OUTDOOR CUSHION
FABRIC: MUSTIQUE 13 MUSCHIO (ART LIFESCAPE 13)

SAKI CORD OUTDOOR ISLAND SX CM 168X168 H70 - MOD. B
FABRIC: MUSTIQUE 12 OLIVA (ART LIFESCAPE 13)
FIBRE: MUD COLOUR

SAKI CORD OUTDOOR ARMCHAIRS WITHOUT ARMRESTS CM 80X91 H69
FABRIC: MUSTIQUE 13 MUSCHIO (ART LIFESCAPE 13)
FIBRE: MUD COLOUR

TWIST OUTDOOR THROW CM 170X140 / BAMBOO/CORD COLOUR

KYOTO RUGS CM 250X350 / ASH COLOUR - SPECIAL SIZE

309 - 310/311 - 312 - 313

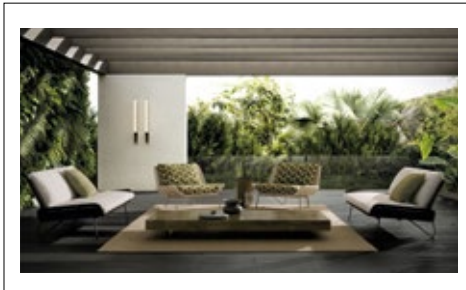

EMMI CORD OUTDOOR SOFAS 190X98 H78
FABRIC: MUSTIQUE 01 BIANCO (ART LIFESCAPE 13)
STRUCTURE: MATT DARK BROWN COLOUR STAINLESS STEEL
CORD: DARK BROWN COLOUR
EMMI CORD OUTDOOR CUSHIONS
FABRIC: MUSTIQUE 12 OLIVA (ART LIFESCAPE 13)

EMMI CORD OUTDOOR ARMCHAIRS CM 97X98 H78
EMMI CORD OUTDOOR FOOTSTOOL CM 88X55 H42
FABRIC: HAITI 04 OLIVA (ART LIFESCAPE 13)
STRUCTURE: MATT ECRU COLOUR STAINLESS STEEL
CORD: BUTTER COLOUR

ANDRÉE OUTDOOR COFFEE TABLE CM 215,5X94,5 H24
STRUCTURE COVER: GLAZED PUTTY COLOUR CERAMIC

ANDRÉE OUTDOOR COFFEE TABLE CM 35,5X21 H48,5
STRUCTURE COVER: GLAZED PUTTY COLOUR CERAMIC
PLATES: MATT DARK BROWN COLOUR ALUMINIUM

BRAID RUG CM 400X300 / ECRU COLOUR - SPECIAL SIZE

Art Direction

Minotti Studio

Styling

Martina Lucatelli

Photo

Indoor: Paola Pansini

Outdoor: Studio Paola Pansini | Emanuele Camisassa

Many thanks to:

6:AM, Italy
 ALEXA LIXFELD, Germany
 ANNA TORFS, Czech Republic
 ARCHIVIO SALOCCHI STUDIO, Italy
 ARNOLFO DI CAMBIO, Italy
 ARTEMIDE, Italy
 ASTEP, Denmark
 BALTENSWEILER, Swiss
 BAROVIER & TOSO, Italy
 BELUX, Germany
 BOVER, Spain
 CARLO MORETTI, Italy
 COLLEVILCA, Italy
 DANESE MILANO, Italy
 DECHEM STUDIO, Czech Republic
 DISDEROT, France
 ELOA, Germany
 ESPERIA, Italy
 FONTANAARTE, Italy
 GARDECO, Belgium
 HANNES PEER
 IGUZZINI, Italy
 JUNIOR B, Italy
 KNINDUSTRIE, Italy
 KREOO, Italy
 LEUCOS, Italy
 LINEA LIGHT GROUP - Italy
 LUCEPLAN, Italy
 LYFA, Denmark
 MARIA CALDERARA, Italy
 MARIE BECKMAN, Sweden
 MARIO CIONI, Italy
 MARSET, Spain
 MARTIN POTSCHE, Germany
 MARTINELLI LUCE, Italy
 MAZZEGA 1946, Italy
 MUTINA, Italy
 NEMO LIGHTING, Italy
 OLUCE, Italy
 ORREFORS, Sweden

PAOLA C., Italy
 PINETTI, Italy
 POLLICE ILLUMINAZIONE, Italy
 PURHO, Italy
 QU_LIGHTING, Italy
 SALVIATI, Italy
 SANTA&COLE, Spain
 SERAFINO ZANI - NUMA LIMITED EDITION, Italy
 STELTON, Denmark
 STILNOVO, Italy
 STUDIO IAN MCDONALD, New York city
 TATO ITALIA, Italy
 TECNOLUMEN, Germany
 VIBIA, Spain
 VISTOSI, Italy
 WHEN OBJECTS WORK, Belgium
 ZANAT, Bosnia and Herzegovina
 ZANETTO, Italy
 YALI GLASS, Italy

Special thanks to artists and galleries:

ARIANNA ELLERO, Italy
 ARTESILVA, Italy
 APALAZZO GALLERY, Italy
 JELENA RAJOVIĆ, Serbia
 NICOLAS MAKELBERGE, Sweden

Website

minotti.com

Contact

E.: info@minotti.it

T.: +39 0362 343499

Address

Minotti SpA

via Indipendenza, 152

20821 Meda (MB) - Italy

Follow us

@minotti_spa



WeChat

**Edition**

Printed in April 2025

Copyright

© 2025 Minotti SpA.

All rights reserved.

Any reproduction,
 representation
 or modification,
 in full or partly,
 is expressly prohibited.

Minotti SpA reserves
 the right to change, at any time
 and without prior warning,
 the technical specification
 of any product illustrated
 in this catalogue.

